

ANSYS POLYSTAT User's Guide



ANSYS, Inc.
Southpointe
275 Technology Drive
Canonsburg, PA 15317
ansysinfo@ansys.com
<http://www.ansys.com>
(T) 724-746-3304
(F) 724-514-9494

Release 14.0
November 2011

ANSYS, Inc.
is certified to
ISO 9001:2008

Copyright and Trademark Information

© 2011 SAS IP, Inc. All rights reserved. Unauthorized use, distribution or duplication is prohibited.

ANSYS, ANSYS Workbench, Ansoft, AUTODYN, EKM, Engineering Knowledge Manager, CFX, FLUENT, HFSS and any and all ANSYS, Inc. brand, product, service and feature names, logos and slogans are registered trademarks or trademarks of ANSYS, Inc. or its subsidiaries in the United States or other countries. ICEM CFD is a trademark used by ANSYS, Inc. under license. CFX is a trademark of Sony Corporation in Japan. All other brand, product, service and feature names or trademarks are the property of their respective owners.

Disclaimer Notice

THIS ANSYS SOFTWARE PRODUCT AND PROGRAM DOCUMENTATION INCLUDE TRADE SECRETS AND ARE CONFIDENTIAL AND PROPRIETARY PRODUCTS OF ANSYS, INC., ITS SUBSIDIARIES, OR LICENSORS. The software products and documentation are furnished by ANSYS, Inc., its subsidiaries, or affiliates under a software license agreement that contains provisions concerning non-disclosure, copying, length and nature of use, compliance with exporting laws, warranties, disclaimers, limitations of liability, and remedies, and other provisions. The software products and documentation may be used, disclosed, transferred, or copied only in accordance with the terms and conditions of that software license agreement.

ANSYS, Inc. is certified to ISO 9001:2008.

U.S. Government Rights

For U.S. Government users, except as specifically granted by the ANSYS, Inc. software license agreement, the use, duplication, or disclosure by the United States Government is subject to restrictions stated in the ANSYS, Inc. software license agreement and FAR 12.212 (for non-DOD licenses).

Third-Party Software

See the legal information in the product help files for the complete Legal Notice for ANSYS proprietary software and third-party software. If you are unable to access the Legal Notice, please contact ANSYS, Inc.

Published in the U.S.A.



TABLE OF CONTENTS

TABLE OF CONTENTS.....	I
CHAPTER 1 INTRODUCTION.....	1
1.1 Objectives	1
1.2 How to Characterize Mixing?.....	1
1.3 Classification of flows, capabilities of the mixing module	3
1.4 General explanation on the way to solve a mixing task.....	6
1.5 The numerical techniques involved in the mixing module	8
1.6 Examples	9
1.6.1 EXAMPLE 50 : The rectangular cavity.....	9
1.6.2 EXAMPLE 51 : Coextrusion of polymers in a square channel.....	9
1.6.3 EXAMPLE 52 : flat die.....	9
1.6.4 EXAMPLE 46 : Periodic flow through a Kenics Mixer.....	10
1.6.5 EXAMPLE 37 : Mixer 2-D	10
1.6.6 EXAMPLE 65 : Adaptive Meshing for Moving Parts; mixer-2D	10
1.6.7 EXAMPLE 91 : Dispersion	10
CHAPTER 2 THE MIXING THEORY.....	11
2.0 Introduction	11
2.1 Kinematic Parameters.....	12
2.1.1 Kinematic Parameters for 2D flows	13
2.1.2 Kinematic Parameters for 3D flows	14
2.1.3 Statistical analysis	16
2.1.3.1 Mean and Standard Deviation	16
2.1.3.2 Cumulated Probability Function (or Distribution Function)	16
2.1.3.3 Density of Probability Function	17
2.1.3.4 Percentiles	18
2.1.3.5 Histograms.....	18
2.1.3.6 Correlations.....	19
2.2 Homogenization.....	19
2.2.1 Definition.....	19
2.2.2 Numerical method	21
2.3 Distributive mixing	23
2.3.1 Distribution index	23



2.3.2 Distribution in Zones 25
2.3.3 Deviation of points concentration 27
2.4 Disagglomeration 28
2.5 Comment 33
2.6 Bibliography 34

CHAPTER 3 MIXING TASK IN POLYDATA 35

3.1 The "Create a new Task" Menu 36
3.2 General Menu of a Mixing Task; 37
3.3 Definition of the flow domain 38
3.4 Definition of the boundary conditions 39
3.5 Definition of the flow field 46
 3.5.1. Steady State Flow 46
 3.5.2. Time Dependent Flow 47
3.6 Parameters for the Generation of the material points 50
3.7 Parameters for the Tracking 55
3.8 Parameters for the Kinematic Mixing Properties 57
3.9 Selection of Properties 58
3.10 Parameters for the Storage of the Results 60
3.11 Definition of moving parts 62

CHAPTER 4 THE POLYSTAT USER'S MANUAL 63

4.1 the FILE menu 65
 4.1.0 the "Open .." option 66
 4.1.1 the "Options" option 66
 4.1.2 the "READ data" option 67
 4.1.3 the "READ mesh" option 68
 4.1.4 the "RUN" option 69
 4.1.5 the "DRAW results" option 70
 4.1.6 the "DRAW stat." option 73
 4.1.7 the "WRITE trajectories" option 75
 4.1.8 the "WRITE slices." option 77
 4.1.9 the "WRITE stat." option 79
 4.1.10 the "Save .." option 80
4.2 the PROPERTIES menu 81
 4.2.1 Definition 81
 4.2.2 See PROPERTIES 82
 4.2.3 Create PROPERTIES 83
 4.2.3.1 |A| 84
 4.2.3.2 A^x 86



4.2.3.3 exp(A)	86
4.2.3.4 log(A)	86
4.2.3.5 A+B, A-B	86
4.2.3.6 A/B	86
4.2.3.7 A*B	87
4.2.3.8 Rotation	88
4.2.3.9 Translate	90
4.2.3.10 Integrate	91
4.2.3.11 Derivate	92
4.2.3.12 k	93
4.2.3.13 A(slice)	94
4.2.3.14 Concentration	95
4.2.3.16 Extract	97
4.2.3.17 Step	98
4.2.3.18 Instantaneous efficiency of Mixing	99
4.2.3.19 Time Averaged efficiency of Mixing	100
4.2.4 Disagglomeration PROPERTIES	101
4.2.4.1 Disagglomeration	102
4.2.4.2 Typical size of agglomerateS	103
4.2.4.3 Fraction of agglomerates of given size	104
4.2.4.4 Number of agglomerates of given size	105
4.2.4.5 Mass of agglomerates of given size	106
4.3 the TRAJECTORIES menu	107
4.3.1 See set of TRAJECTORIES	107
4.3.2 the "CREATE a new set of trajectories" option	109
4.3.3 the "COMBINE sets of trajectories" option	110
4.3.4 the "SELECT one single trajectory" option	111
4.3.5 the "SEARCH Stagnation Points" option	112
4.4 the SLICES menu	114
4.4.1 See set of SLICES	115
4.4.2 the "Automatic Slicing" option	116
4.4.3 the "manual Slicing" option	117
4.4.4 the "sub- Slicing" option	118
4.5 the STATISTICS menu	120
4.5.1 See STATISTICAL functions	120
4.5.2 Create STATISTICAL functions	121
4.5.2.0 the "See property along a trajectory" function	123
4.5.2.1 the "SUM" function	124
4.5.2.2 the "MEAN & STANDARD DEVIATION" function	125
4.5.2.3 the "CORRELATION" function	126
4.5.2.4 the "PROBABILITY" function	127
4.5.2.5 the "Auto-Correlation On Concentration" function	128
4.5.2.6 the "Distance distribution" function	129
4.5.2.7 the "distribution in zones" function	131
4.5.2.8 Arithmetic operation on sum functions	133
4.5.2.9 Smoothing on functions	134



4.5.2.10 the "DENSITY of Probability" function	136
4.5.2.11 the "Percentiles" function	137
4.5.2.12 the "Histograms" function.....	139
4.5.2.13 the "Segregation Scale" function.....	140
4.5.2.14 the "Deviation" function	141
4.5.2.15 the "Points Concentration Deviation" function	143
4.5.3 New Disagglomeration Functions	145
4.5.3.0 the "See disagglomeration along a single trajectory" function;	146
4.5.3.1 the "Mean disagglomeration" function	147
4.5.3.2 the "Probability" function.....	149
4.6 The HELP Menu.....	151
4.7 Additional definitions	152
4.7.1 The slices	152
4.7.2 The zones.....	153
4.7.3 Weighting.....	154
ADDENDUM A.- THE SIMULATION OF THE DISTRIBUTION	155
ADDENDUM B.- THE GLOBAL EFFICIENCY OF STRETCHING	156
ADDENDUM C.- ADAPTIVE MESHING AND MIXING TASK	157
ADDENDUM D.- SLIDING MESH TECHNIQUE AND MIXING TASK ...	158



CHAPTER 1

INTRODUCTION

1.1 OBJECTIVES

In industry the mixing process is widely present; it occurs in different kind of machines, in a continuous or batch process, like in Banburry mixers, Kenics mixers, extruders, stirred vessels, and so on. The objectives are various too: distribution of pigments or other compatibilizers, generation of interfaces between different fluids in order to enhance chemical reactions, ...

The main objective of this module is to offer the user the ability to quantify the mixing in the process of his interest. We will define later a set of objective parameters that are relevant for different situations. But we tried to go a step further; there is, at this time, always a certain evolution in the way scientists are quantifying mixing. That's why we developed software that uses existing parameters and allows the user to also define new parameters.

This module simulates mixing for various flows, but the situation is in general so complex, that numerical simulation cannot take into account all the real phenomena existing in such processes. In a next section of this chapter, we will explain the needed assumptions and hypotheses.

1.2 HOW TO CHARACTERIZE MIXING?

There are various ways to define the process of mixing. Dankwertz in the 50'ies analyzed the mixing as an homogenization process of a concentration field; initially two different fluids are separated in two adjacent zones; as the time goes on, the local concentration of each fluid evolves everywhere in the fluid, and if the mixing is perfect, the concentration must tend to the same value everywhere in the flow; to quantify this homogenization process, Dankwertz defined two parameters; firstly, the segregation scale is the average thickness of the striations existing in the flow domain. Secondly, the intensity of segregation is the standard deviation of the concentration around its mean. These parameters are used when there are only two fluids to mix, and when their proportion in the flow domain is more or less equivalent.

Later, in the 80'ies, Ottino defined other parameters based on the Continuum Mechanics Theory. He showed that mixing is a process increasing the interface existing between fluids. But instead of measuring the surface of the interface (that is almost impossible in complex flows), he prefers to measure local increases of infinitesimal surfaces distributed everywhere in the flow.

But these parameters are not very useful if we analyze the distribution of a small amount of pigments, tracers, and so on in the flow domain (small percentage in volume of the total flow



domain). Based on the work of Manas-Zloczower, we have defined a new parameter δ in order to measure this process; let us suppose that initially, we place a set of particles in a small zone in the flow domain, as a function of time, these particles move in the flow and distribute. Our parameter δ measures the deviation of the current distribution with respect to a perfect distribution of particles in the flow domain.

Another technique similar to the previous one is now available: we divide the flow domain in a set of adjacent (and non-overlapping) zones. Initially, we place a set of particles in a small box in the flow domain, and they distribute progressively. Then, for a given time, we count the number of points in each zone. We get a good distributive mixing, if each zone contains a number of points proportional to its surface/volume.

A third option to estimate distributive mixing is to evaluate the local points concentration in various locations in the flow domain, and to compare it with a perfect points concentration, corresponding to the case where we find the same number of points per unit volume everywhere in the mixer. Eventually, a new parameter δ_p measures the deviation in points concentration.

The dispersive mixing is another important aspect of the mixing: it concerns the break-up of drops into small droplets or the disagglomeration of solid particles in a matrix. The stress applied by the matrix on drops or on solid particles is the "engine" that can lead to dispersion: if the stresses are high enough to compete with surface tension of drops or with internal mechanic resistance of solid particles, dispersion occurs. Dispersion will be better if some elongational effect exists in the flow. This information is available by adding some post-processors, while defining the set-up for the flow calculation. Next, it will be possible to evaluate them along trajectories of material points. Moreover, a model has been included in Polystat to calculate the disagglomeration process along trajectories.

We have found a general and accurate method to calculate all these parameters in a single simulation. The main steps of this method are: firstly, we calculate the flow as usual, secondly, we compute the trajectories of a large set of material points (initially concentrated in the whole flow domain or not), with in complement the calculation along these trajectories of the local deformation of the matter and other relevant properties. Finally, we analyze these results with statistical tools in order to obtain a global, objective, and quantitative overview of the mixing evolution.



1.3 CLASSIFICATION OF FLOWS, CAPABILITIES OF THE MIXING MODULE

With the mixing module, all the kind of flows cannot be studied. There exist limitations.

But first, let us define some concepts:

- **Open / Closed domain:** a closed domain is a domain where there is no entry and no exit of fluid. An open domain is the opposite.

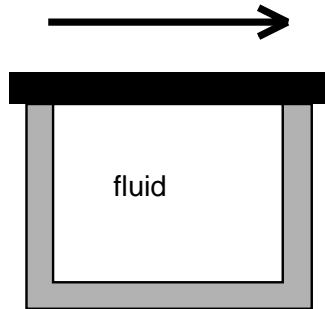

the square cavity, a closed domain

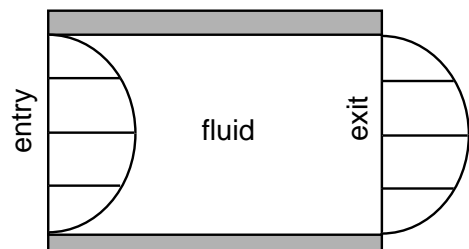

the channel flow, an open domain

- **Steady state / Time dependent flow:** a steady flow is a flow that does not change with time. The general case of a time dependent flow is a flow that evolves continuously with time; our mixing module can study these two kinds of flow. However, for transient flows, the flow domain must not change with time except for flows with moving parts simulated with the 'mesh superposition' technique. If the flow is transient, we have to calculate and store the current flow at successive time steps; let's note them $\text{flow}(t_1)$, $\text{flow}(t_2)$, ... However, in order to calculate particles path, we have to know the velocity field at intermediate times : two techniques are implemented ;
- In the first case, the piecewise steady case, we assume the flow is steady between two time steps t_1 , t_2 (with $t_1 < t_2$), and is equal to $\text{flow}(t_1)$. This assumption is valid if inertia is neglected and if the boundary conditions change abruptly. One example is the oscillating square cavity :

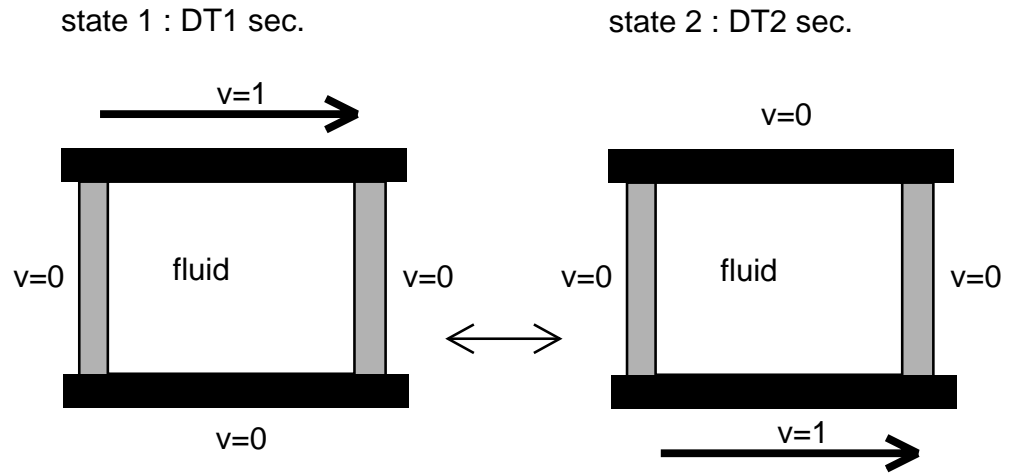

Example of a piecewise steady flow

In this case, two velocity fields alternate. The first state lasts for DT1 seconds; the upper wall moves to the right while the other walls are at rest. The second state lasts for DT2 seconds; the lower wall moves to the right while the other walls are at rest. With such a flow, we can obtain a far better mixing than with a steady state flow.

- In the second case, the more general, the flow changes continuously between t_1 and t_2 ; the flow at time t , will be a linear combination of $\text{flow}(t_1)$ and $\text{flow}(t_2)$:

$$\text{flow}(t) = (1-\alpha) \text{flow}(t_1) + \alpha \text{flow}(t_2),$$

$$\text{with } \alpha = \frac{t-t_1}{t_2-t_1}, \text{ and } t_1 \leq t \leq t_2, t_2 \neq t_1.$$

- **Spatially periodic flows** : the flow is spatially periodic if there exists an elementary "module" on which we can calculate the flow field and where the velocity field in the inflow section is equal (exactly) to the velocity field in the outflow section. A spatially periodic flow is necessarily a flow through an open domain.

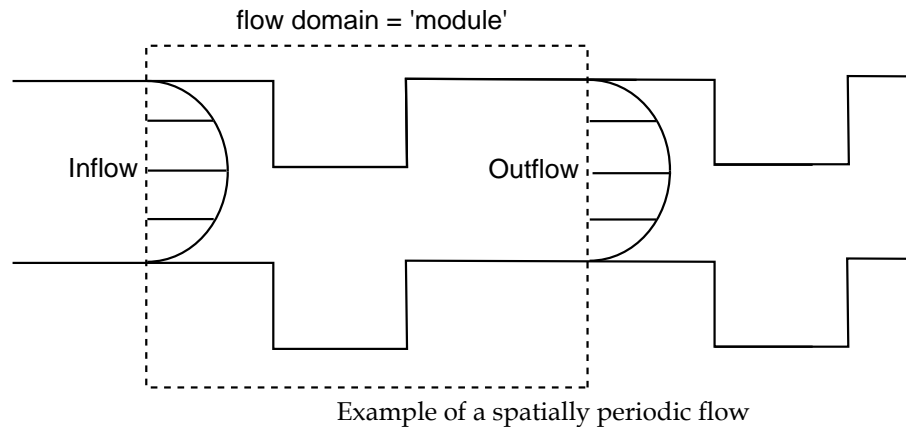

The flow field is repeated infinitely in space : the flow field in the next module is the same as in the current module, and in the previous module, and so on ...

The limitations of our module are the following :

- Geometrical limitations : the domain must not change with time : we have to find a frame of reference where the **domain** occupied by the flow does not vary. For example, if one wants to analyze mixing in a single screw extruder, we assume the screw to be fixed and the barrel to be rotating. If there are moving internal parts, the 'mesh superposition' technique must be used to simulate their motion !
- For a piecewise steady flow, there **must be** no inertia.
- The flow **must always be** incompressible.
- There is no void formation in the flow. The flow domain is completely filled with the same fluid : if we want to mix two or several fluids, they must have the same rheological behavior, no diffusion nor chemical reactions between them, and no interfacial tension.

It is thus clear that, despite the fact that we calculate a mixing problem, the flow calculation is identical to that of a single homogeneous fluid. We will examine the time dependence of a set of mixing parameters without making any distinction between the fluids we want to mix.

However, there is **no** limitation on :

- the model of fluid : generalized Newtonian or visco-elastic models are available.
- the dimensional complexity of the problem : 2D planar, 2D axisymmetric, 2D 1/2 planar (3 components for the velocity field), 2D 1/2 axisymmetric (swirling flows), 3D.
- the thermal complexity of the problem : isothermal or non-isothermal simulations are possible.



1.4 GENERAL EXPLANATION ON THE WAY TO SOLVE A MIXING TASK

Three major steps must be performed in order to solve a mixing task : i. we calculate the flow, ii. we calculate a set of trajectories, iii. we perform statistics on this set.

- The flow simulation : we have to define a finite element mesh (via Gambit, Icem, Patran, ...); next, we enter in Polydata where a F.E.M. task is defined in order to calculate the flow ONLY. With the data file, we run POLYFLOW, and finally we obtain a Polyflow result file containing the velocity field, the shear rate, and other fields of interest. If the flow is transient, it is recommended to save the Polyflow results files at exacts time steps Δt . However, if the flow is piecewise-steady with N successive boundary conditions (N small, in loop or not), it is sometimes easier to perform N Polydata sessions, one for each specific set of boundary conditions. We will run POLYFLOW N times, one for each data file, and we will obtain N result files, containing each one a set of fields specific to a particular set of boundary conditions.

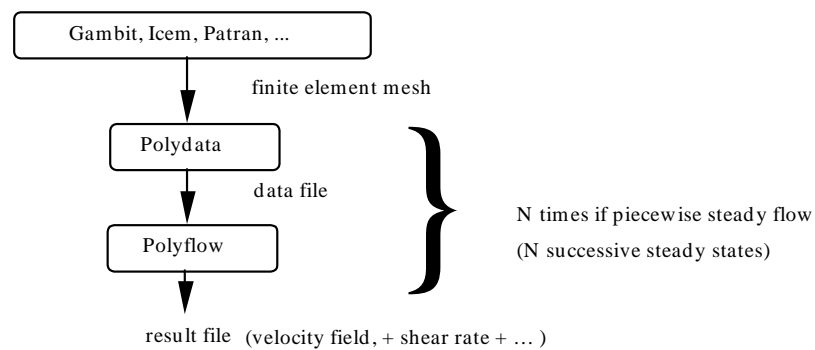

- The mixing simulation : in a second step, we enter back in Polydata to define a MIXING task : we specify the mesh, the velocity fields to use and the initial position of the material points and other properties to evaluate along trajectories. Next, we run POLYFLOW with this data file : POLYFLOW generates randomly the initial position of a set of material points, and calculates their trajectory in the flow domain. Along these trajectories, POLYFLOW calculates also the evolution of some properties and kinematic parameters (temperature, viscosity, stretching, rate of stretching, rate of dissipation, ...). And finally, POLYFLOW generates files containing these results.

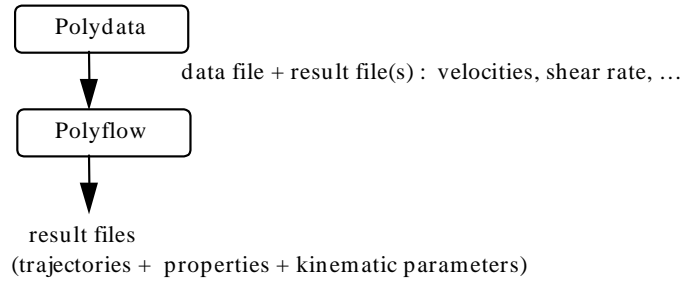

- The statistical post-processing : finally, we use the post-processor Polystat to analyze all these trajectories : we will calculate the time evolution of global mixing parameters such as the segregation scale or the evolution of the mean stretching, and so on.

Polystat has been built in such a way that we can define new parameters and test them. New parameters are created by combining existing parameters in various ways (+, -, *, /, ||, $\sqrt{\quad}$, \int , $\frac{\partial}{\partial t}$, ...). In such a way, Polystat can also be used to analyze other processes than mixing; for example, the quality of a molten glass exiting a furnace. Eventually, we calculate statistical functions of these parameters; these functions can be visualized inside Polystat, Excel, ...

It is also possible to visualize with Polystat the spatial distribution of a kinematic parameter at a given time, or in a cutting plane, or along a given trajectory.

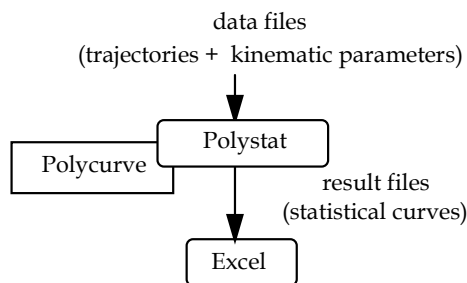



1.5 THE NUMERICAL TECHNIQUES INVOLVED IN THE MIXING MODULE

Generally, the trajectories are calculated by the time integration of the equation $\dot{\mathbf{x}} = \mathbf{v}$ with an Euler explicit scheme ; it's enough if we are only interested in the successive positions of material points. But if we need to know precisely the deformation accumulated along these trajectories, a very accurate numerical technique is required.

We chose to combine two techniques : first, we use an explicit Runge-Kutta scheme of the fourth order; second, instead of integrating the motion of a particle in the real space, we perform a coordinate transformation : we calculate the trajectory in the parent element : we integrate with the Runge-Kutta method

$$\dot{\xi} = f(\mathbf{v}(\xi)) \quad (1)$$

To know the successive positions of the particle in the real space, we use

$$\mathbf{x} = \sum_i \mathbf{x}_i \psi_i(\xi) \quad (2)$$

The algorithm is the following :

1. initialization :

- find an element E, containing the initial position \mathbf{X} ;
- find the local coordinates ξ of \mathbf{X} in this element E;

2. while (no problem & no required stop) {

\Rightarrow • we integrate equation (1), until we cross a boundary of the element E ;

- if a boundary of E is crossed, we adapt the time step of integration in such a way that the position is on the boundary ;
- if we are on a boundary of E, in \mathbf{x} ,
 - we search the element adjacent to E where to continue the integration; let's note this element E^* ;
 - find the local coordinates ξ^* in element E^* of the current position \mathbf{x} ;
 - go to (\Rightarrow) ;

}

We explained this, because some important numerical parameters used by this algorithm must be defined by the user in Polydata (see Chapter 3, Parameters for the tracking) : for example, we must define the coefficient NBELEM that indicates the mean number of integration steps necessary to cross an element.



1.6 EXAMPLES

Here below, one can find a short description of the POLYFLOW examples devoted to mixing. Refer to the documents corresponding to those examples for their full description (on the POLYFLOW Documentation CD).

1.6.1 EXAMPLE 50 : THE RECTANGULAR CAVITY

This example is the tutorial of the mixing module !

In this first example, we will compare the mixing efficiency of a steady state flow with a piecewise steady flow. It is 2D planar and isothermal flow problem.

We explain in detail how to use Polystat : a) how to create new properties, b) how to define a slicing on time, and c) how to define the statistical functions needed for the comparison of the two cases. Moreover, we explain how to extract useful information from those statistical curves.

Keywords : piecewise steady flow, distributive mixing, reorientation process, mixing efficiency, Polystat, statistical analysis

1.6.2 EXAMPLE 51 : COEXTRUSION OF POLYMERS IN A SQUARE CHANNEL

In this second example, two viscoelastic fluids are injected in a channel. They have identical rheological properties but different colors. We analyze the axial evolution of the interface between those fluids in the square channel: we calculate the axial evolution of the segregation scale in order to quantify the progressive deformations of the interface in the channel.

Keywords : 2D 1/2 planar flow, viscoelasticity, coextrusion, secondary motion, Polystat, concentration field, segregation scale

1.6.3 EXAMPLE 52 : FLAT DIE

In this third example, we will analyze a 3D steady state non-isothermal flow through the die section of an extruder. We are specially interested by the residence time distribution and the 'melting' characteristics of the matter leaving the die.

Keywords : 3D steady state flow, non-isothermal, flat die, Polystat, statistical analysis, residence time distribution, melting index



1.6.4 EXAMPLE 46 : PERIODIC FLOW THROUGH A KENICS MIXER

In this fourth example, we analyze the distributive mixing generated by a Kenics mixer. As the complete flow domain is too large to be used, we reduce the flow calculation to a single mixing element of the mixer. We assume the flow field to be spatially periodic. We analyze the generation of striations through successive mixing sections and the efficiency of the process.

Keywords : 3D steady state flow, periodic boundary conditions, static mixer, Polystat, distributive mixing

1.6.5 EXAMPLE 37 : MIXER 2-D

In this fifth example, we simulate the 2-D transient flow produced by the rigid rotation of two cams in a batch mixer. Moreover, we evaluate the dispersive mixing capability of the mixer. Forces and torque along the cams are also evaluated.

Keywords : mesh superposition technique, batch mixer, transient flow problem, forces and torque, dispersive mixing, mixing index, eigen values of the stress tensor, shear rate, vorticity, Polystat, statistical analysis

1.6.6 EXAMPLE 65 : ADAPTIVE MESHING FOR MOVING PARTS; MIXER-2D

In this 6-th example, we simulate the 2-D transient flow produced by the rigid rotation of two cams in a batch mixer. As in example 37, we use the mesh superposition technique to take into account the rotation of the cams. Moreover, we use adaptive meshing to refine the mesh locally in the neighborhood of the cams, in order to get more accurate evaluation of the flow field. As the mesh changes with time, it cannot be used anymore to perform tracking of material points : we have first to save the flow field in a set of csv files, that we map onto a new uniformly refined mesh. The tracking is eventually performed on this new mesh, with the mapped flow field.

Keywords : mesh superposition technique, batch mixer, time dependent flow, adaptive meshing, conversion form CSV files, mixing task, statistical analysis

1.6.7 EXAMPLE 91 : DISPERSION

In this 7-th example, we present the models of erosion and rupture in a simple shear flow. By this way, we analyze the effect of various functions and parameters of these models.

Keywords : dispersion, disagglomeration, erosion, rupture, Polystat



CHAPTER 2

THE MIXING THEORY

2.0 INTRODUCTION

In polymer blending, a minor component is generally present as drops (or filaments) in a continuous phase of a major component. Mixing is a process of deformation and rupture of the drops but also a process of 'distribution' of those drops in the whole flow domain. A good mixing is characterized by small and identical drops distributed uniformly in the all flow domain.

Deformation of drops is promoted by the viscous stress τ exerted on the drops by the flow field and counteracted by the interfacial stress σ/R , where σ is the interfacial tension and R , the local radius. The capillary number Ca is useful to characterize mixing:

$$Ca = \frac{\tau R}{\sigma} \quad (0)$$

For a given pair of polymers, a critical Capillary number may be found. It corresponds to the situation where the viscous stress competes with the interfacial stress: the drop is extended and finally breaks up into smaller droplets. We name this process "dispersive mixing". Let us note that an extensional flow field is more efficient to break up drops into droplets than a shear flow.

If the capillary number is much higher than the critical capillary number, then the viscous stress overrules the interfacial stress, and the drop is extended but does not break up ; this process is called "distributive mixing". On the contrary, if the capillary number is much lower than the critical capillary number, then the interfacial stress dominates and the drop is only slightly deformed.

In general, mixing begins with a 'distributive' step (drops are deformed passively), followed by a 'dispersive' one (drops break up into droplets), and finally by the distribution of the droplets in the flow. In the paragraphs below, we concentrate mainly on distributive mixing (§ 2.1 and § 2.2) and on distribution of material points into the flow domain (§ 2.3). However, dispersive mixing can also be analyzed: the user can add post-processors to the flow calculation : a) the mixing index (or 'flow number') indicates if the flow is locally a rigid motion (mixing index = 0), a shear flow (mixing index = 0.5), or in extension (mixing index = 1), b) the eigen values of the extra-stress tensor T : with this field we have access to the main component of the stress, which stretches and breaks the drops. Once the flow and those post-processors are determined, we can calculate the evolution of the mixing index and the main stress along the trajectories of material points. With those data we can evaluate the fraction of the matter experiencing a given stress value, and then evaluate the efficiency of the dispersive mixing.



We call also "dispersive mixing" the process where solid particles are broken by erosion or rupture in smaller parts due to stresses applied on them by the matrix (carbon black or silica in a rubber matrix, for example). A new model has been developed by B. Alsteens and V. Legat (see ref. [7]) to simulate this process of disagglomeration : thanks to them, this model is already available in Polystat. The description of the model can be found in § 2.4.

2.1 KINEMATIC PARAMETERS

A first way to measure mixing is to quantify the capacity of the flow to deform matter and to generate interface. In the theory presented below, we neglect interfacial forces : the interface is passive and no break-up into droplets can occur !

For 2D flows, the interface between fluids is a line; in order to avoid to calculate the evolution of this interface (a very complex and impossible task to perform, because of the exponential growth of the interface), we prefer to calculate the stretching of infinitesimal vectors attached to a large number of material points distributed in all the flow domain. As the points move in the flow, the vectors are stretched. The stretching and the rate of stretching of these vectors are interesting properties that vary from place to place in the flow domain, and that evolve with time. Finally, we perform a statistical analysis of the set of results in order to have a global overview of the process. With such a method, we can have an objective and quantitative evaluation of the mixing of any process; we can, for example, find areas in the domain where the mixing is poor (low stretching instead of exponential increase). For 3D flows, we generalize the concept : the interface is now a surface and we will calculate the stretching of infinitesimal surfaces attached to material points.

Let Ω^0 and Ω denote the domain occupied by the homogeneous fluid at time 0 and t, respectively. The motion of the fluid is described by the relationship

$$\mathbf{x} = \chi(\mathbf{X}, t) \quad (1)$$

where \mathbf{X} denotes the position of a material point P in Ω^0 and \mathbf{x} in Ω . The symbols \mathbf{F} and \mathbf{C} denote the deformation gradient and the right Cauchy Green strain tensor between both configurations. The velocity gradient and the rate of deformation tensor at time t are denoted by \mathbf{L} and \mathbf{D} , respectively. For later use, we note that

$$\dot{\mathbf{F}} = \mathbf{L}\mathbf{F} \quad (2)$$

where a dot denotes the material time derivative.



2.1.1 KINEMATIC PARAMETERS FOR 2D FLOWS

Consider in Ω_0 a material fiber $d\mathbf{X}$ with a unit orientation \mathbf{M} which deforms into a material fiber $d\mathbf{x}$ with a unit orientation \mathbf{m} at time t . Let λ denote the length stretch $|d\mathbf{x}|/|d\mathbf{X}|$. It is easy to show (see ref. [3]) that

$$\lambda(\mathbf{X}, \mathbf{M}, t) = \sqrt{\mathbf{M} \cdot \mathbf{C} \mathbf{M}} \quad (3)$$

while \mathbf{m} is given by

$$\mathbf{m} = \frac{\mathbf{F} \mathbf{M}}{\lambda} \quad (4)$$

A good mixing quality requires high values of λ throughout time and space. A local evaluation of the efficiency of mixing (see ref. [2]) is given by the ratio

$$e_\lambda(\mathbf{X}, \mathbf{M}, t) = \frac{\dot{\lambda}/\lambda}{D} \quad (5)$$

where $D = \sqrt{\text{tr} \mathbf{D}^2}$. The values of this instantaneous efficiency are always included in the interval [-1; 1]. We can easily show that

$$e_\lambda(\mathbf{X}, \mathbf{M}, t) = \frac{\mathbf{m} \cdot \mathbf{D} \mathbf{m}}{D} \quad (6)$$

We note that e_λ is a local measure along the path of a material point; the time averaged efficiency is defined as

$$\langle e_\lambda \rangle(\mathbf{X}, \mathbf{M}, t) = \frac{1}{t} \int_0^t e_\lambda(\mathbf{X}, \mathbf{M}, t') dt' \quad (7)$$

However, there exists another way to define a mean efficiency over time :

$$\langle e_\lambda \rangle_2(\mathbf{X}, \mathbf{M}, t) = \frac{\int_0^t \dot{\lambda}/\lambda dt'}{\int_0^t D dt'} = \frac{\ln(\lambda)}{\int_0^t D dt'} \quad (8)$$



The physical interpretation of (8) is the following : **for one material point**, at time t, $\langle e_\lambda \rangle_2$ is the ratio of what we get (the final stretching obtained at time t) over what we put (the total mechanical dissipation until time t).

Eventually, we can define a global efficiency over all the material points distributed initially in the flow :

$$\langle\langle e_\lambda \rangle\rangle (\mathbf{M}, t) = \frac{\int_{\Omega_0} \ln(\lambda) d\Omega}{\int_{\Omega_0} \int_0^t D dt' d\Omega} \quad (9)$$

This global efficiency is the ratio of the output -the mixing obtained- (the total stretching of the matter until time t) over the input -the "energy" we get- (the total mechanical dissipation until time t).

2.1.2 KINEMATIC PARAMETERS FOR 3D FLOWS

For 3D flows, we will calculate the local stretching of infinitesimal surfaces by the mean of the area stretch η .

In the initial configuration Ω_0 , let define an infinitesimal surface 'dA' with a normal direction $\hat{\mathbf{N}}$. With time, this surface deforms; at time t, this surface is noted 'da', with a new normal direction $\hat{\mathbf{n}}$. The area stretch η is the ratio of the deformed surface 'da' at time t over the initial surface 'dA' :

$$\eta = \eta(\mathbf{X}, \hat{\mathbf{N}}, t) = \frac{da}{dA} \quad (10)$$

If the fluid is incompressible, we obtain (see ref. [2]) :

$$\eta = \sqrt{\hat{\mathbf{N}}^t (\mathbf{C}^{-1}) \hat{\mathbf{N}}} \quad (11)$$

If the fluid is incompressible, the normal direction to the surface 'da' is :

$$\hat{\mathbf{n}} = \frac{(\mathbf{F}^{-1})^t \hat{\mathbf{N}}}{\eta} \quad (12)$$



A good mixing quality requires high values of η throughout time and space. A local evaluation of the efficiency of mixing (see ref. [2]) is given by the ratio

$$e_{\eta}(\mathbf{X}, \hat{\mathbf{N}}, t) = \frac{\dot{\eta}/\eta}{D}. \quad (13)$$

The values of this instantaneous efficiency are always included in the interval [-1; 1]. After some transformations, it is easy to show that

$$e_{\eta}(\mathbf{X}, \hat{\mathbf{N}}, t) = \frac{-\hat{\mathbf{n}}^t \mathbf{D} \hat{\mathbf{n}}}{D}. \quad (14)$$

We note that e_{η} is a local measure along the path of a material point; the time averaged efficiency is defined as

$$\langle e_{\eta} \rangle(\mathbf{X}, \hat{\mathbf{N}}, t) = \frac{1}{t} \int_0^t e_{\eta}(\mathbf{X}, \hat{\mathbf{N}}, t') dt'. \quad (15)$$

However, there exists another way to define a mean efficiency over time :

$$\langle e_{\eta} \rangle_2(\mathbf{X}, \hat{\mathbf{N}}, t) = \frac{\int_0^t \dot{\eta}/\eta dt'}{\int_0^t D dt'} = \frac{\ln(\eta)}{\int_0^t D dt'} \quad (16)$$

Like for (8), the physical interpretation of (18) is the following : **for one material point**, at time t , $\langle e_{\eta} \rangle_2$ is the ratio of what we get (the final stretching obtained at time t) over what we put (the total mechanical dissipation until time t).

Like for 2D kinematic parameters, we can define a global efficiency over all the material points distributed initially in the flow :

$$\langle\langle e_{\eta} \rangle\rangle(\hat{\mathbf{N}}, t) = \frac{\int_{\Omega_0} \ln(\eta) d\Omega}{\int_{\Omega_0} \int_0^t D dt' d\Omega} \quad (17)$$



2.1.3 STATISTICAL ANALYSIS

Let us assign to the N material points an initial orientation \mathbf{M} , which does not need to be identical for all points. While tracking the material points as a function of time, we also calculate successive values of λ , e_λ and $\langle e_\lambda \rangle$. A global representation of λ , e_λ and $\langle e_\lambda \rangle$ is again obtained by associating a material point with a small rectangle of size $dx \times dy$; the color of the rectangle is associated with the value of the field to be represented. The quality of the representation increases with the number of points N .

When the number of material points is sufficiently large, we may proceed with a statistical treatment of the calculated quantities. Several statistical tools have been implemented in the new software POLYSTAT.

2.1.3.1 MEAN AND STANDARD DEVIATION

For any scalar kinematic parameter α , we can calculate the time evolution of its mean and its standard deviation :

$$\bar{\alpha}(t) = \frac{\sum_{i=1}^N \alpha_i(t)}{N} \quad (18)$$

$$\sigma_\alpha^2(t) = \frac{\sum_{i=1}^N (\alpha_i(t) - \bar{\alpha}(t))^2}{N} \quad (19)$$

2.1.3.2 CUMULATED PROBABILITY FUNCTION (OR DISTRIBUTION FUNCTION)

Let us now define the distribution function F_α associated with the scalar field α . The quantity $F_\alpha(\beta, t)$ is defined as follows,

$$F_\alpha(\beta, t) = P[\alpha(t) \leq \beta], \quad (20)$$

where the right-hand side is the probability that the field α be smaller than β at time t .



A new graph of the distribution function is calculated at every time t (see figure below).

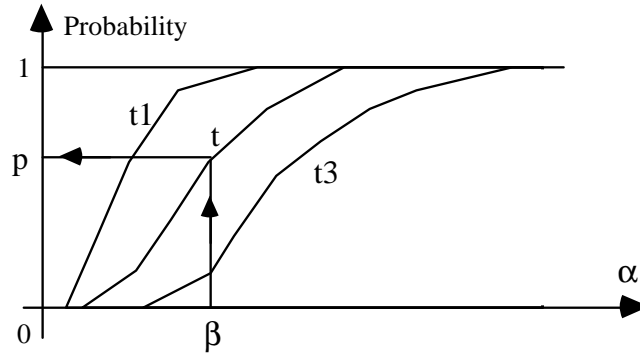

2.1.3.3 DENSITY OF PROBABILITY FUNCTION

Based on the distribution function F_α of a scalar field α , we can define the density of probability function $f_\alpha(\beta, t)$ as follows,

$$f_\alpha = \frac{\partial F_\alpha}{\partial \alpha} . \tag{21}$$

The function $f_\alpha(\beta, t)$ is the frequency with which we find a value of α in the range $[\beta - \Delta\alpha; \beta + \Delta\alpha]$ at time t . A new graph of the density of probability function is calculated at every time t (see figure below).

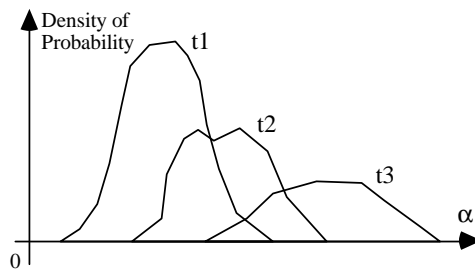



2.1.3.4 PERCENTILES

An easier representation of the mixing progress is based on the time dependence of percentiles. For the field α , let us define $\alpha_p(t)$ such that

$$F_\alpha(\alpha_p, t) = p ; \tag{22}$$

$\alpha_p(t)$ indicates that, at time t , p % of the material points have a value of α lower than $\alpha_p(t)$, as you see on the figure below :

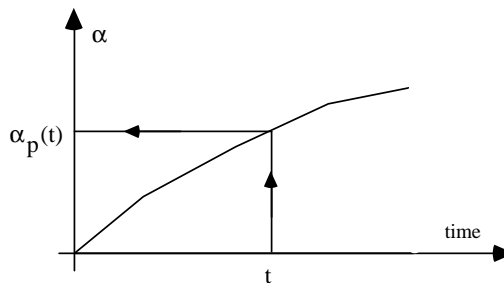

With the percentiles, we can study the evolution of the mixing for specific fractions of the population of material points; it's interesting, for example, to know the value of the length stretch reached by the 5 or 10 % of the points with the lowest stretching; these percentiles can easily show local defects in the stretching.

2.1.3.5 HISTOGRAMS

Another way to represent the frequency of values of a field α is to define histograms : the user specifies a set of intervals of values of α , and he obtains the percentage of the points population that have a value of α in each interval at time t (see figure below) :

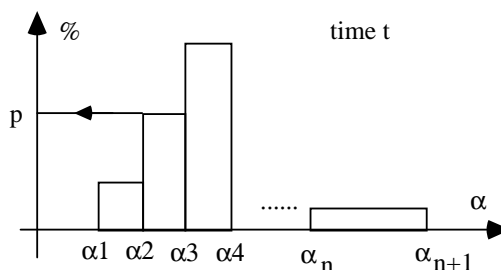

We see that p % of the points population has a value of α between α_1 and α_2 at time t .



2.1.3.6 CORRELATIONS

Finally, once the number of material points is sufficiently large, it is possible to examine the correlation between fields either at the same or at different times.

We have to define two times (t_1 and t_2), and two fields (α and β). For every material point, we plot $\alpha(t_1)$ in abscissa and $\beta(t_2)$ in ordinate; an analysis of the graph reveals a possible correlation between the fields.

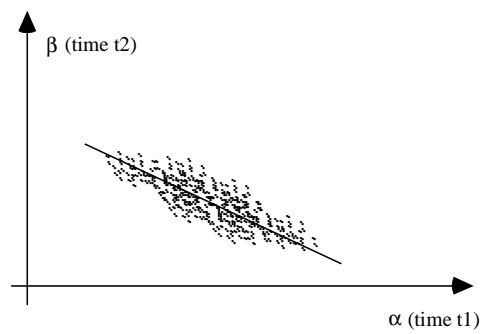

2.2 HOMOGENIZATION

2.2.1 DEFINITION

Suppose we want to mix two fluids A and B : both fluids occupy at time $t=0$ two separated zones of the flow domain (see figure below).

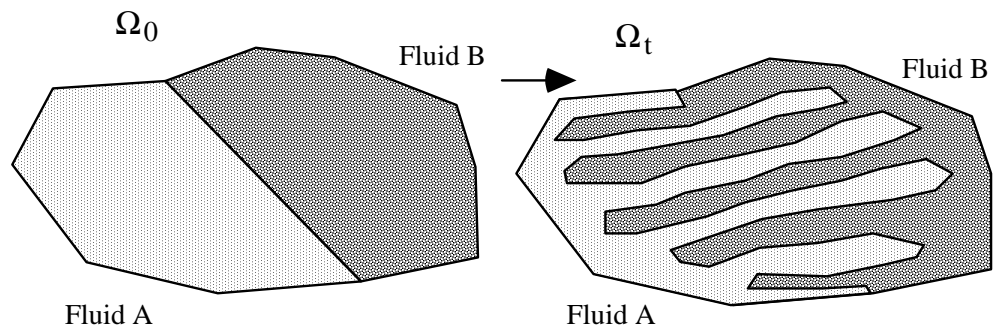



Let $c(\mathbf{X}, t)$ denote the concentration of fluid A throughout the mixing process. Since no diffusion occurs between fluids A and B, we conclude that c equals either 0 or 1 and remains constant along the trajectory of a material point. Its evolution is governed by the transport equation

$$\dot{c} = 0. \tag{23}$$

The concept of concentration allows us to introduce the notion of segregation scale (see ref. [1] and [4]). At time t , consider a set of M pairs of material points separated by a distance r . For the j -th pair and time t , let c'_j and c''_j denote the concentrations at both points of the pair; moreover, let \bar{c} denote the average concentration of all points and σ_c the standard deviation. At time t , the correlation coefficient $R(r, t)$ for the concentration is defined as follows,

$$R(r, t) = \frac{\sum_{j=1}^M (c'_j - \bar{c})(c''_j - \bar{c})}{M \sigma_c^2}. \tag{24}$$

The function $R(r, t)$ gives the probability of finding a pair of random points with a relative distance r and with the same concentration.

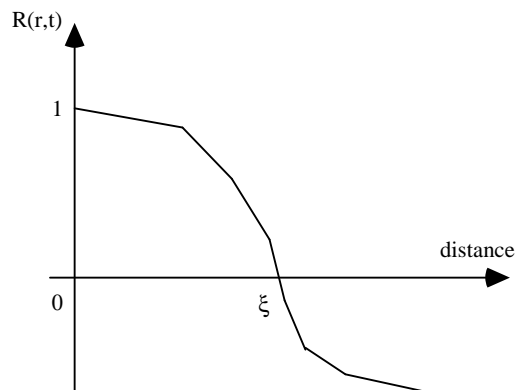

The Figure above shows a typical graph of R as a function of r . Let ξ be such that $R(\xi, t) = 0$; when $r = \xi$, we cannot predict whether the members of the pair have the same concentration or not. The segregation scale $S(t)$ is defined as

$$S(t) = \int_0^{\xi} R(r, t) dr. \tag{25}$$



It is easy to understand that $S(t)$ is a measure of the size of the regions of homogeneous concentration. $S(t)$ decreases when mixing improves.

While quantities such as λ , e_λ and $\langle e_\lambda \rangle$ are proper to the flow, irrespective of the initial concentration, the segregation scale $S(t)$ is a quantity affected by the flow but which depends strongly upon the initial distribution of concentration.

Remark : Dankwertz defined another parameter, the intensity of segregation :

$$I(t) = \frac{\sigma_c^2(t)}{\sigma_c^2(0)} \quad (26)$$

Because of our assumptions (the concentration attached to any material point remains constant with time), this parameter does not change with time and will not be calculated.

2.2.2 NUMERICAL METHOD

We distribute uniformly (but randomly) a set of material points in all the flow domain at time $t = 0$. To each point is associated a concentration depending on its situation in a zone of fluid A ($c=1$) or a zone of fluid B ($c=0$).

When time progresses, we calculate the new location of each point; it is easy to visualize the current state of the concentration field : for each point, we plot in the domain a small pixel (if 2D flow) with the appropriate color. Once the successive coordinates of material points are stored, a minor effort is needed to calculate at time t the concentration corresponding to another set of initial conditions. The limitation of the method lies of course in the size of the material point identified by the pixel, but the number of points can be increased at will together with the computation time.

Let us now assume that we have tracked N material points. It is easy to calculate the average and the standard deviation of the concentration :

$$\bar{c} = \frac{1}{N} \sum_{i=1}^N c_i \quad , \quad (27)$$

$$\sigma_c = \left(\frac{1}{N} \sum_{i=1}^N [c_i - \bar{c}]^2 \right)^{1/2} \quad , \quad (28)$$

where c_i is the concentration (0 or 1) of the material point i .



Let d_{\max} be the maximum distance between two material points in the flow domain. We will calculate $nbval$ values of the correlation function for distances uniformly distributed between 0 and d_{\max} . To calculate one value of correlation function (for a distance d), we select randomly $nbpair$ pairs of points if their relative distances are in the interval $\left[d - \frac{d_{\max}}{2 nbval}; d + \frac{d_{\max}}{2 nbval} \right]$. The correlation coefficient $R(r, t)$ is completed by a linear interpolation through the discrete calculated values. The segregation scale $S(t)$ may then be easily calculated by numerical integration on the basis of equation (25).

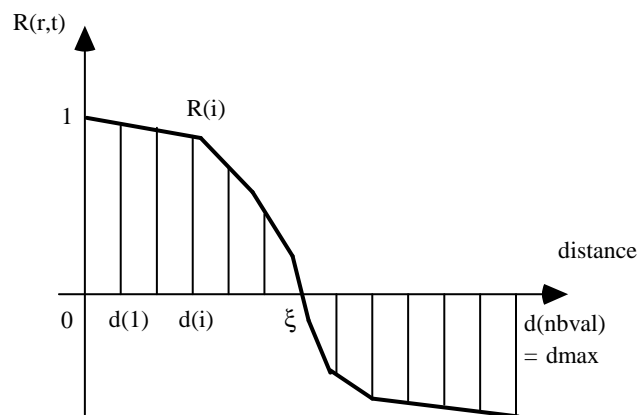

There exists a limitation to this method : as the number of points is finite, the mean size of the pixels is finite too; we cannot calculate *accurately* a segregation scale that is smaller than this characteristic size. If the segregation falls below that size, that means that the mean thickness of the striations in the flow is smaller than the size of the pixels : the concentration field will appear like a random distribution of pixels of the two colors : there are no more continuous lines of one color. Another problem of the segregation scale is that it cannot detect a local defect in the flow; **it is a global index** of the quality of mixing. Finally, the segregation scale **depends** on the size of the flow domain.

The parameters of this method are :

- The initial distribution of the zones of fluid A and B.
- d_{\max} : the maximum possible distance between two points in the flow domain.
- $nbpair$: the number of pairs of points necessary to calculate **one** value of the correlation function
- $nbval$: the number of values of the correlation function to calculate



2.3 DISTRIBUTIVE MIXING

2.3.1 DISTRIBUTION INDEX

Suppose we want to distribute a cluster of particles initially concentrated in a small box (see figure below). We suppose that the particles do not affect the flow field and that there is no interaction between them. Their number is supposed to be large.

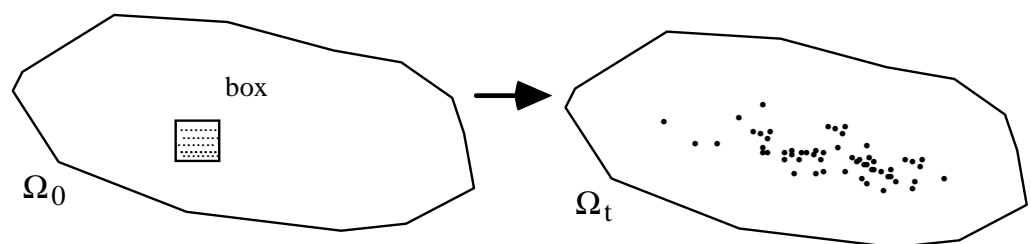

As a function of time, the flow will distribute this set of points. It's important to define a distribution index δ to quantify this process. Its definition is based on the work performed by Manas-Zloczower and her colleagues (see refs. [5,6]).

At time t , we have N points distributed (more or less) in the flow domain.

Option 1 : These points can form $N(N-1)/2$ pairs of points. For each pair of point \mathbf{x}_i and \mathbf{x}_j , we calculate their inter- distance $d_{ij} = \|\mathbf{x}_i - \mathbf{x}_j\|$. The maximum inter-distance will be of the order of the diameter of the mixer.

Option 2 : For each point \mathbf{x}_i , we search its closest neighbor \mathbf{x}_j and we store their inter-distance $d_{ij} = \|\mathbf{x}_i - \mathbf{x}_j\|$. We have thus only N distances. With this method of calculation, we are able to better discriminate distributive capacities of similar mixers. The maximum inter-distance will be of the order of $\sqrt[3]{V/N}$, where V is the volume of the mixer.

With this set of distances, we can calculate the density of probability function on the distance $f(d)$: the probability to find a pair of points (chosen randomly) such that their inter-distance is included in range $[d, d+\Delta d]$ at time t is : $f(d)\Delta d$.

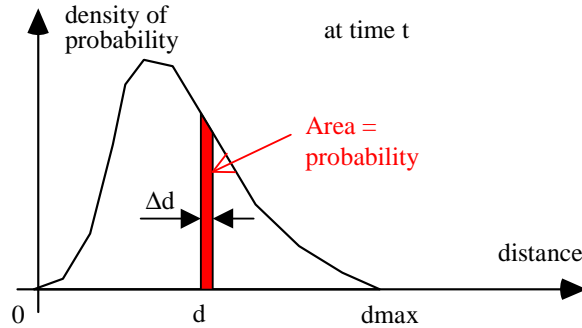

Suppose on the other hand, that you have distributed randomly a same number of points in all the flow domain; we can assume that such distribution is ideal. With the same tools, we can calculate the function $f(d)$ for this optimal distribution. It is noted $f^{opt}(d)$.

The distribution index δ is defined as the deviation of the function $f(d)$ (real distribution) from the function $f^{opt}(d)$ (optimal distribution) :

$$\delta(t) = \frac{1}{2} \int_0^{+\infty} |f(l) - f^{opt}(l)| dl, \quad \delta \in [0, 1] . \quad (29)$$

As the distribution improves, the index δ decreases. This index is dimensionless: it is independent of the size of the flow domain. The evolution of δ depends -of course- on the initial position of the box. Another important parameter not to forget is the number or material points to distribute : a careful analysis must be done to measure its influence.

Two other parameters can also be evaluated :

- The difference of the means :

$$\delta_m(t) = \bar{d} - \bar{d}^{opt} \quad \text{with} \quad \bar{d} = \int_0^{\infty} d f(l) dl \quad (30)$$

- The difference of the standard deviations :

$$\delta_s(t) = \sigma - \sigma^{opt} \quad \text{with} \quad \sigma^2 = \int_0^{\infty} (d - \bar{d})^2 f(l) dl \quad (31)$$

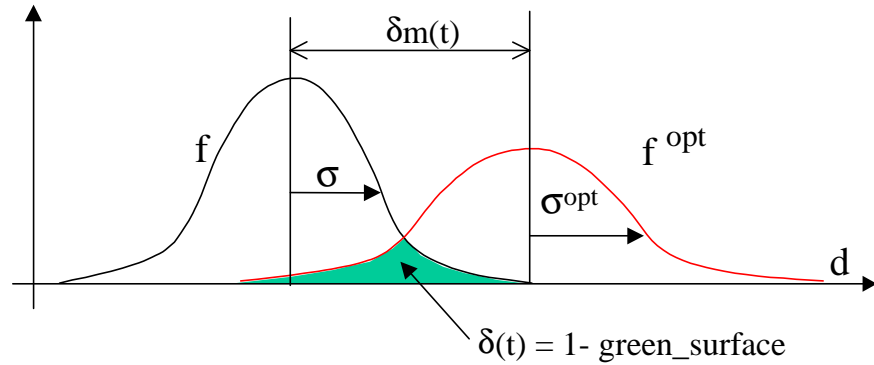

As for the segregation scale, such parameters have limitations : as they are global indices, we cannot detect local defects.

2.3.2 DISTRIBUTION IN ZONES

As for the distribution index, we want to quantify distributive mixing. But with this new method, we will be able to detect zones of the mixer where material points are missing, and where there is an excess of points.

As usual, we distribute a cluster of particles initially concentrated in a small box (see figure below).

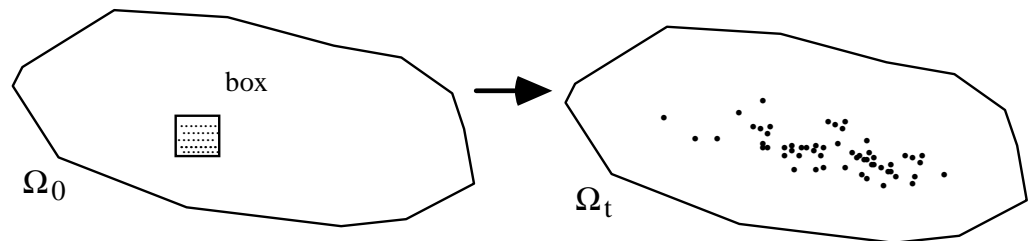

As a function of time, the flow will distribute this set of points.

We define a set of adjacent and non-overlapping zones covering all the flow domain.



In the figure below, we have four zones :

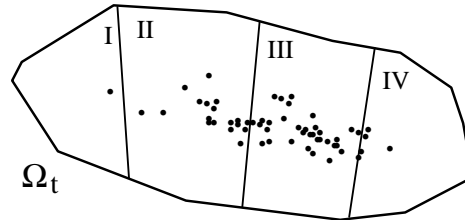

Next, we distribute randomly in all the flow domain, the **same** number of points N : we assume that such a distribution is the optimal one.

At time t , for each zone, for the two distributions, we will determine the number of points included in it. Based on these numbers, we can evaluate a relative error of distribution for each zone Z :

$$\varepsilon(Z) = \frac{\text{nbr}(Z) - \text{nbo}(Z)}{N}, \tag{32}$$

where nbr is the number of points of the real distribution included in zone Z , at time t and nbo is the number of points of the optimal distribution included in the same zone.

If ε is zero for a zone, the right number of points is found in that zone,

If ε is negative for a zone, there is a lack of points in that zone compared to optimum,

If ε is positive for a zone, there are too many points in that zone compared to optimum.

Eventually, we can define a global index based on all the zones :

$$\varepsilon_g = \frac{1}{2} \sum_{z=1}^{\text{nb.zones}} |\varepsilon(z)| \tag{33}$$

The number of points and the zones partitioning can influence dramatically the indices described above. When comparing two different mixers, it is recommended to keep constant the ratio number of points/zone. In order to have relevant results, this ratio should be higher than 100 !



2.3.3 DEVIATION OF POINTS CONCENTRATION

As for the distribution index, we want to quantify distributive mixing. However compared to that parameter, we do not need to compute a perfect points distribution; we just need the actual one.

As usual, we distribute a cluster of particles initially concentrated in a small box (see figure below).

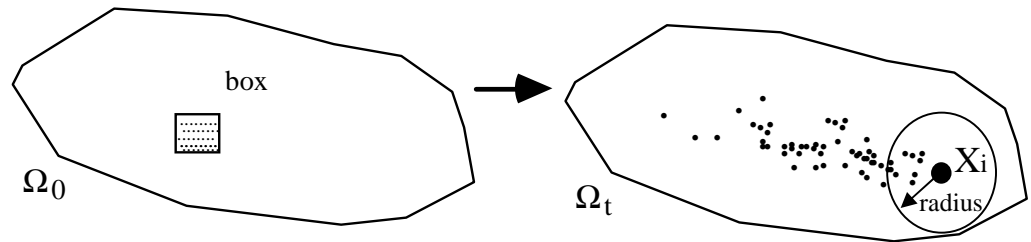

As a function of time, the flow will distribute this set of points.

At time t , we have N points distributed (more or less) in the flow domain.

For each point \mathbf{x}_i , we search its neighbors $\{\mathbf{x}_j\}$ that stay at a distance smaller than a sample radius. Depending on the dimensionality dim of the cluster of points at time t , we can evaluate the local points concentration $\phi(\mathbf{x}_i)$:

$$\text{For } dim = 1, \quad \phi(\mathbf{x}_i) = N_x / (2 \text{ radius});$$

$$\text{For } dim = 2, \quad \phi(\mathbf{x}_i) = N_x / (\pi \text{ radius}^2);$$

$$\text{For } dim = 3, \quad \phi(\mathbf{x}_i) = N_x / \left(\frac{4}{3} \pi \text{ radius}^3\right);$$

where N_x is the number of points of the cluster around \mathbf{x}_i at a distance smaller than the radius.

On the other side, at perfect distribution, we expect that the points are distributed equally in all the flow domain; we should find everywhere the same number of points per unit volume. Then, we can easily determine the perfect points concentration ϕ_p : it corresponds to the number of points divided by the volume of the flow domain. For other situations, the reader can easily adapt the method of evaluation of the perfect points concentration, as explained in § 4.5.2.15.



Eventually, the standard deviation δ_p of points concentration at time t is evaluated as follows:

$$\delta_p(t) = \sqrt{\frac{\sum_{i=1}^N [\phi(\mathbf{x}_i) - \phi_p]^2}{N}}, \quad (34)$$

where N is the number of points in the cluster at time t , the $\{\mathbf{x}_i\}$ correspond to the location of points i at time t and ϕ_p is the perfect points concentration.

If one looks carefully at this definition, the user must be aware that we evaluate points concentration only at positions where there are points! There is no points concentration evaluation in zones of the mixer empty of material points! If distributive mixing improves, the points concentration deviation should decrease. At perfect distribution, we should have same points concentration in any location in the cluster, and the deviation δ should be zero.

2.4 DISAGGLOMERATION

We wish to evaluate the dispersive mixing of solid particles in a fluid matrix in studying the evolution of the size of the agglomerates [7, 8]. Let us consider a set of agglomerates of different sizes at the start of the mixing in an internal mixer. In each point of the volume of the mixer, we define a little volume V_x , called representative volume, that contains agglomerates of different sizes as illustrated here below:

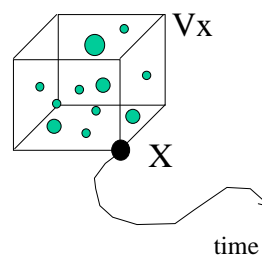

If the number of agglomerates is large enough in volume V_x , this distribution of agglomerates sizes can be summarized in a mass density function $f(s,t)$, where t is the time and s the size (mean diameter) of the agglomerate. Its unit is $[1/\mu\text{m}]$.



It is discretized by a piecewise-linear curve:

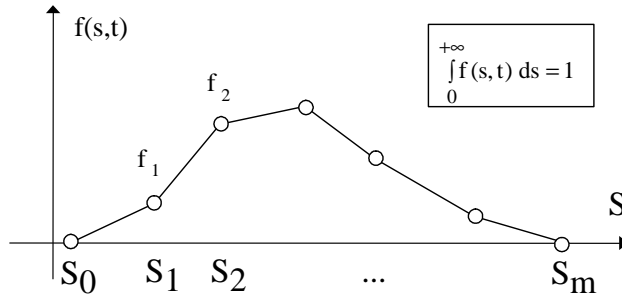

The mass fraction of agglomerates of size in interval $[S_a; S_b]$ is : $\int_{S_a}^{S_b} f(s) ds$.

Of course this "mass fraction" distribution will change with time, as the volume V_x attached to the point X moves in the mixer, because of erosion and rupture taking place during mixing. We assume there is no transfer of agglomerates between adjacent volumes, due to the high viscosity of the matrix.

Erosion is a slow and continuous process observed for all admissible sizes of agglomerates. This process generates a lot of small particles. Rupture occurs when a critical stress is reached and is observed for large particles. This process generates two or more agglomerates.

Erosion and rupture depend on the size of agglomerates, the shear rate and the shear stress. In the following text, we distinguish two types of solid particles: the aggregates and the agglomerates. The first ones are the smallest particles that can not be eroded or broken anymore. The second ones are larger particles formed of a number of aggregates linked together by cohesive forces.

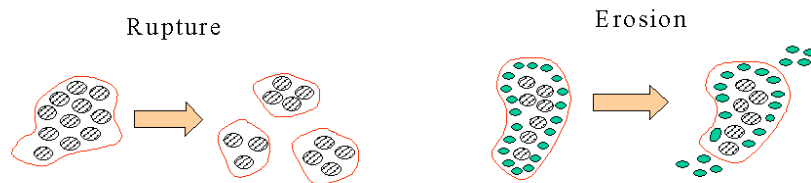

Erosion

The erosion model implemented in Polystat is based on the work of Collin and Peuvrel-Disdier [9] on the dispersive mixing of carbon black agglomerates N234 in a SBR matrix. Of



course, due to the large variety of models and raw materials, it is possible to adapt or modify the implemented model (accessible in the CLIPS file "disagglomeration.clp" that can be found in \$POLYFLOW/bin directory): the corresponding functions are interpreted by Polystat at run time. We consider hereafter the case of low concentration of carbon black pellets, meaning that we neglect erosion due to friction between pellets: we only consider erosion due to hydrodynamic forces.

During erosion, small particles are removed continuously from the agglomerates that diminish in size. This removal can occur if the shear stress σ is above a given threshold $\sigma_{crit}^{erosion}$. In this case, if we assume that agglomerates are roughly spherical, the variation of size Δs of the agglomerate after Δt seconds can be described as follows:

$$\frac{\Delta s}{\Delta t} = -\frac{8\alpha(\sigma - \sigma_{crit}^{erosion})\dot{\gamma}}{3S^2}, \quad (35)$$

where α is a coefficient of proportionality, $\dot{\gamma}$ the local shear rate and S the size of the agglomerate at time t and $S+\Delta S$ will be the new size of the agglomerate at time $t+\Delta t$.

Based on the assumption of mass conservation, the mass distribution function becomes:

$$f(s + \Delta s, t + \Delta t) = \frac{(s + \Delta s)^3}{s^3} f(s, t) \quad (36)$$

Moreover, as the total mass of solid particles is constant in the control volume V_x , the mass fraction of aggregates increases as the mass fraction of agglomerates decreases (because of their reduction in size, their number staying constant). This can be seen in the next figure, where we see the effect of erosion on an initial set of agglomerates with sizes ranged between 15 and 25 microns. They are mixed in a matrix with a viscosity of 11000 Pa.s. We applied a constant shear rate of 10 s^{-1} and we plot the mass distribution function every 25 seconds. We observe the shift to left, the widening and flattening of the Gaussian curve centered initially at 20 microns as erosion develops. But we observe also an increasing peak at extreme left of the graph, in the small sizes, corresponding to the generation of aggregates.

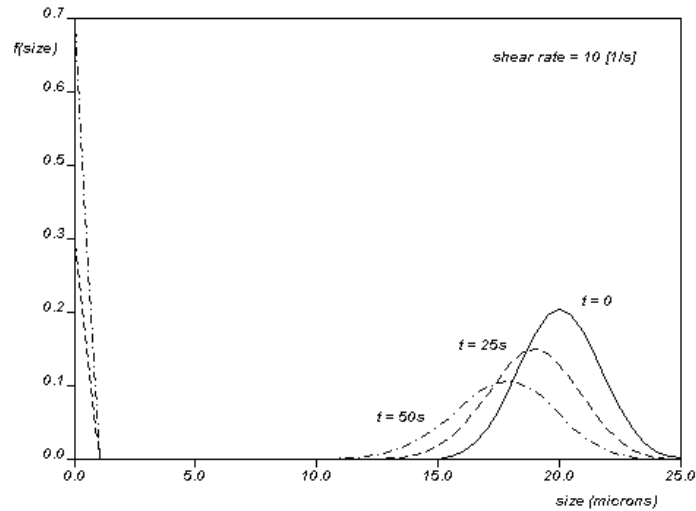

Effect of erosion on the mass distribution function as a function of time; the matrix viscosity is 11000 Pa.s and the shear rate is 10 s⁻¹.

Rupture

For the model of rupture, also based on [9], we assume that the rupture into a few fragments occurs if an agglomerate is submitted to a shear stress higher than a critical shear stress during a given amount of time (called rupture time). This critical shear stress for rupture function of size S can be written:

$$\sigma_{\text{crit}}^{\text{rupture}}(S) = \sigma_{\text{min}} + \frac{\beta}{S} \quad (37)$$

Indeed, we are more interested by the inverse relation: we have to know which agglomerates can break for a given shear stress σ . The equation (37) becomes:

$$S_c = \frac{\beta}{(\sigma - \sigma_{\text{min}})} \quad (38)$$

All agglomerates with a size greater than S_c can break for a shear stress σ .

In our model, we assume that the rupture time is a constant (the default value is set to 0.1 seconds in the disagglomeration.clp file) and that only a fraction of all particles of a given size will break if rupture criteria are met. Indeed, we can understand easily that all particles of a given size do not have same cohesion or same impregnation level (infiltration of the matrix inside the agglomerate due to diffusion). That is why we can specify the rupture rate, the



fraction of particles that break when rupture criteria are met (however, the default value is set to 1 in the `disagglomeration.clp` file, meaning that all agglomerates break).

Eventually, we have to model how a set of agglomerates of size S will break in numerous fragments of various sizes. We assume here that the volumes of the fragments follow a Gaussian distribution between 0 and the parent agglomerate volume. In average, the parent agglomerates (of size S) are cut into two fragments of equal volume, leading to a mean size of $0.8S$. Of course, once again, this behavior can be modified by changing the corresponding function in the `disagglomeration.clp` file. The transfer function for rupture can be seen in the following figure, with a rupture rate of 1:

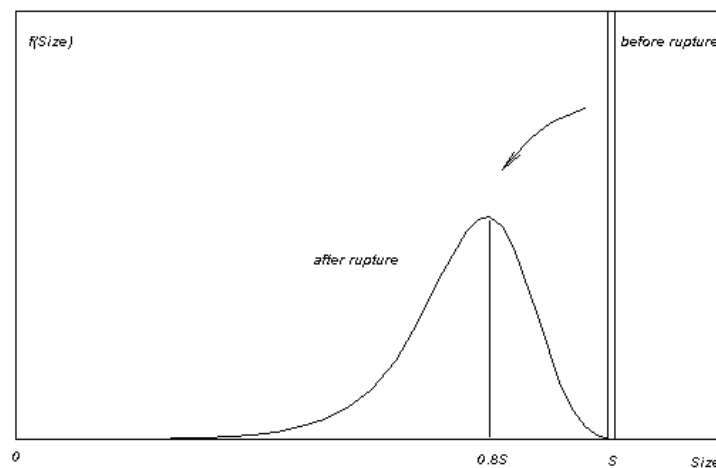

Transfer function for rupture, with a rupture rate of 1 and a mean size of fragments equal to 0.8 times the parent size S .

Let us briefly enter in the details of implementation of the rupture model. We associate to each discretized agglomerate size S_i an induction time τ_i initialized to zero. As we progress along the trajectory, we evaluate the shear stress σ ; based on equation (38), we get immediately all the classes where rupture can occur. For classes $S_i < S_c$, their induction time τ_i is reset to zero. For the other classes, their associated induction time is increased by the local time step Δt . For all classes where the induction time is above the rupture time, the rupture occurs and the corresponding induction time is reset to zero (also for agglomerates that do not break, phenomenon occurring when the rupture rate is not 100%). Regarding now classes with $S_i \geq S_c$, but with an induction time below the rupture time; they can receive fragments but does not break. Their mass frequency f_i increases, but their induction time τ_i must be modified, because we assume that incoming fragments come with their own (zero) induction time.



We apply the following rule:

$$\tau_i(t+\Delta t) = [\tau_i(t) + \Delta t] \cdot \Gamma\left(\frac{f_i(t)}{f_i(t+\Delta t)}\right) \quad (39)$$

where Γ is a function of the ratio of mass frequency f_i of class S_i at previous time t and current time $t+\Delta t$. By default, we define Γ as:

$$\Gamma(\text{ratio}) = \text{ratio}. \quad (40)$$

List of functions used in the erosion and rupture models and available in the disagglomeration.clp file :

DNSPRB : to define the initial mass density distribution function (default = Gaussian distribution between 15 and 25 μm);

EROSION_MODEL : to define the function $\frac{\Delta S}{\Delta t}$ of erosion model (see equation 35);

TRANSFER_RUPTURE : to define the transfer function for rupture model;

CRITICAL_SIZE : to define the minimum size of agglomerates that can break for a given shear stress (see equation 38);

RUPTURE_TIME : to define the amount of time during which the stress must be above required threshold to get rupture;

RUPTURE_RATE : to define the fraction of agglomerates that will actually break if rupture criteria are met;

MODIFY_INDUCTION_TIME : to define the function $\Gamma(\text{ratio})$ (see equation (40)).

2.5 COMMENT

In the presentation of the mixing parameters that we calculate, we always define them as evolving with time. This kind of representation is well suited if the flow occurs in a closed domain ; in that case, the mixing evolves with time.

But what if the flow occurs in an open domain, such as in a single screw extruder, or in a Kenics mixer ? In such a case, the mixing quality evolves from the entry of the machine to the exit. To analyze this process, we generate a set of points in the plane section of the entry; then



we calculate their trajectory through the machine, until they reach the exit. For the statistical analysis, we will generate a set of slicing planes uniformly distributed from the entry to the exit. For each slice, we determine the intersections with the trajectories. Then at these intersections, we interpolate the values of the kinematic parameters. For each slice, we can then calculate the mean value of a field α , or the distribution function of a field β , and so on. As the slices are sorted from the entry to the exit, we can analyze the evolution of the mixing slice by slice.

2.6 BIBLIOGRAPHY

- [1] DANKWERTZ, P.V., 1952, *The Definition and Measurement of some Characteristics of Mixtures*. Applied Science Research. Section A. Vol 3, pp. 279-296.
- [2] OTTINO, J.M., RANZ, W.E., MACOSKO, C.W., July 1981, *A Framework for Description of Mechanical Mixing of Fluids*. AIChE Journal. Vol. 27, n°4, pp. 565-577.
- [3] OTTINO, J.M., 1989, *The Kinematics of Mixing : Stretching, Chaos and Transport*. Cambridge University Press.
- [4] TADMOR & GOGOS, 1979, *Principles of Polymer Processing*. John Wiley and Sons, Chapters 7 and 11.
- [5] WONG, T.H., MANAS-ZLOCZOWER, I., 1994, *Two-Dimensional Dynamic Study of the Distributive Mixing in an Internal Mixer*. Intern. Polymer Proc. Vol. IX, n°1, pp. 3-10.
- [6] YANG, H-H., MANAS-ZLOCZOWER, I., 1994, *Analysis of Mixing Performance in a VIC Mixer*. Intern. Polymer Processing. Vol. IX, n°4, pp. 291-302.
- [7] B. Alsteens, V. Legat, *A Model for the Disagglomeration of Carbon Black in Rubber Matrix*, Proceedings of the 6th Conference Eurheo, Erlangen (Germany), September 2002.
- [8] B. Alsteens, *Mathematical Modelling and Simulation of Dispersive Mixing*, PhD thesis, Université Catholique de Louvain, Louvain-le-Neuve (Belgium), 2005.
- [9] V. Collin, E. Peuvrel-Disdier, *Dispersion Mechanisms of Carbon Black in Elastomers*, Conference on European Rubber Research - Practical Improvement of the Mixing Process, Paderborn (Germany), 2005.



CHAPTER 3

MIXING TASK IN POLYDATA

In order to create a mixing problem, we suppose that in a previous session you defined and solved the Navier-Stokes equations on the flow domain. We have thus one or several result files containing the velocity field. In this session, we will use these velocity fields as data for solving a mixing problem.

When we begin a Polydata session, the initial screen looks like this :

```
*****
*                                     *
*   P O L Y D A T A   *
*                                     *
*****

Version : 3. 12. 0.

# - Save and exit
1) -> 1 - Read a mesh file (enter 1)
      2 - Mesh decomposition and optimization (enter 2)
      # - Combine mesh files
      4 - Convert a mesh file (enter 4)
      # - Convert old results files
      # - Convert old csv files
      6 - Filename syntax (enter 6)
      # - Outputs
      8 - Read an old data file (enter 8)
2) -> 9 - Create a new task (enter 9)
      # - Redefine global parameters of a task

Enter your choice
```

First enter, as usual, the mesh file (option 1).

Next, you will create a new task (option 9). A new menu will appear.



3.1 THE "CREATE A NEW TASK" MENU

```
*****
*
*   Create a new task   *
*
*****

Current setup : - MIXING task
                 - Steady-state
                 - 2D planar geometry

-1 - Accept the current setup      (enter -1 or CR)
 1 - F.E.M. task                   (enter 1)
-> > 2 - MIXING task                 (enter 2)
   > 3 - Steady-state problem(s)    (enter 3)
   4 - Time-dependent problem(s)   (enter 4)
   # - Evolution problem(s)
   # - Optimisation problem(s)
   # - Rigid rotation
   > 7 - 2D planar geometry          (enter 7)
   8 - 2D axisymmetric geometry    (enter 8)
   9 - 2D 1/2 planar geometry       (enter 9)
  10 - 2D 1/2 axisymmetric geometry (enter 10)
   # - 2D shell geometry

Enter your choice
```

Select option 2 to create a new MIXING TASK

By choosing between options 3 or 4, you specify if the flow field (previously calculated) is steady (option 3) or time-dependent (option 4).

Finally, by choosing between options 7 to 10, you specify if the flow is 2D planar, or 2D 1/2 axisymmetric, ... ⁽¹⁾. Let us note that the mixing task is not available for 2D or 3D blow molding.

If you accept the current definition of the problem, select the option (-1); a new menu will appear as you can see on the next page.

(1) If the domain is 3D, you don't have to choose between the options 7 to 10.



3.2 GENERAL MENU OF A MIXING TASK;

```
*****
*
*   MIXING Task 1   *
*
*****

-1 - Upper level menu           (enter -1 or CR)
 1 - Definition of the flow domain (enter 1)
 2 - Definition of the boundary conditions (enter 2)
 3 - Definition of the velocity fields (enter 3)
 4 - Generation of the material points (enter 4)
 5 - Parameters for the tracking (enter 5)
 6 - Parameters for the kinematic variables (enter 6)
 7 - Selection of properties (enter 7)
 8 - Storage of the results (enter 8)
 9 - Definition of moving parts (enter 9)
```

This general menu decomposes a mixing problem in several parts.

The first three options define the flow where material points will travel : we need to know the flow domain (not necessarily the complete domain defined by the mesh), the type of boundaries of this domain (there are several kinds of possible boundary conditions : a material point can cross an entry but not a wall), the velocity fields (necessary to calculate the trajectory of the material points).

In the option 4, we define the zones of the flow domain where we generate the initial position of the material points. This initial position is always determined randomly inside each generation zone.

The option 5 allows the user to specify numerical parameters necessary for the precision of the trajectory calculation in the flow.

With the option 6, we enter numerical parameters necessary for the calculation of the mixing parameters evolving along the trajectories.

Next, with the option 7, we select the properties (mixing parameters, or pressure, temperature, ...) we want to know along the trajectories.

With the option 8, we determine how to store the results of the simulation. With the created result files, we will make a global analysis of the mixing with POLYSTAT.

Finally, with the option 9, we specify the moving parts overlapping the flow domain, if the mesh superposition technique has been used previously to calculate the flow field.



3.3 DEFINITION OF THE FLOW DOMAIN

```
*****  
*                               *  
*   Flow domain                 *  
*                               *  
*****  
  
The current MIXING Task is defined on : whole mesh  
  
-1 - Upper level menu           (enter -1 or CR)  
# - Extension to the whole mesh  
1 - Removal of subdomain 1     (enter 1)  
2 - Removal of subdomain 2     (enter 2)  
3 - Removal of subdomain 3     (enter 3)  
4 - Removal of subdomain 4     (enter 4)  
5 - Removal of subdomain 5     (enter 5)  
6 - Removal of subdomain 6     (enter 6)  
  
Enter your choice
```

With this menu, we can remove (or add) subdomains of the whole mesh in order to define the flow domain, as shown in the example below :

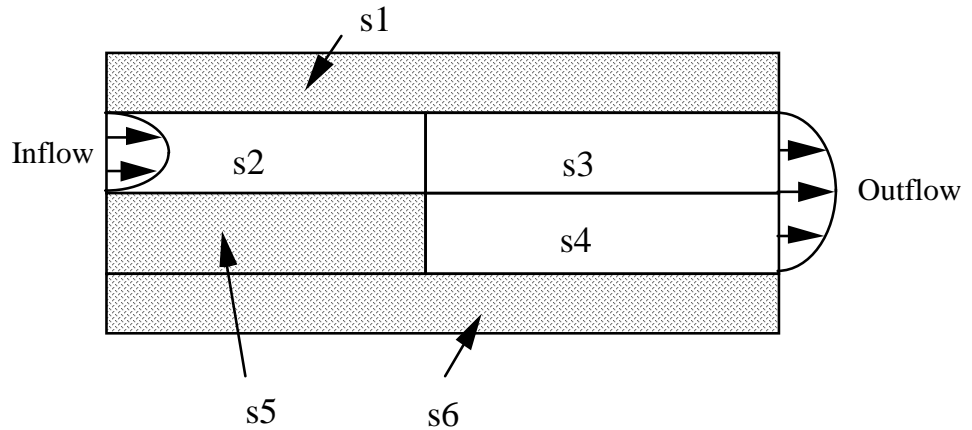

The flow domain is the union of the subdomains s2, s3 and s4. We have to remove the subdomains s1, s5 and s6 (which are solid parts of the problem).



3.4 DEFINITION OF THE BOUNDARY CONDITIONS

```

*****
*                                     *
*   Boundary conditions               *
*                                     *
*****

-1 - Upper level menu                (enter -1 or CR)
  1 - boundary 1 is non-penetrable   (enter 1)
  2 - boundary 2 is non-penetrable   (enter 2)
  3 - Add, Remove or Modify stopping planes (enter 3)

Select the boundary condition you want to modify

```

With this menu, we can make two things. Firstly, we can specify for each boundary its type (wall, entry, exit, ...). Secondly, with the last option, you can add what we call "stopping planes" (this concept is explained below).

By selecting each boundary, we will modify its type if necessary .

A. Specification of the boundary type :

```

*****
*                                     *
*   Boundary condition along boundary 1 *
*                                     *
*****

Current choice : Non-penetrable boundary

-1 - Upper level menu                (enter -1 or CR)
> 0 - Non-penetrable boundary         (enter 0)
  1 - Inflow                          (enter 1)
  2 - Outflow                          (enter 2)
  3 - Entry boundary (in a spatially periodic flow) (enter 3)
  4 - Exit boundary (in a spatially periodic flow) (enter 4)
  5 - Parameters to connect spatially periodic boundaries (enter 5)

Enter your choice

```

By default, the boundary is supposed to be non-penetrable. This type covers the following cases : walls, axes of symmetry, free surfaces. It means that a material point cannot cross the



boundary. If it does however, for numerical reasons, a specific flag attached to each material point is set and the calculation of the trajectory is interrupted (the stopping is ABNORMAL).

But there are other kinds of boundaries :

Option 1, the inflow : it's a part of the boundary where the fluid enters in the flow domain. Normally, a material point cannot cross an inflow boundary (a material point cannot go against the flow, it is not a salmon !).

Option 2, the outflow : it's a part of the boundary where the fluid exits the flow domain. When a material point reaches an outflow boundary, we stop the calculation. In this case, the stopping is NORMAL (in the sense 'regular').

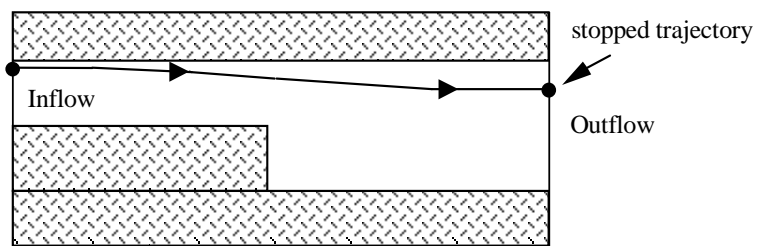

The options 3 to 5 are specific to spatially periodic flows. Remember that a problem is spatially periodic if there exists an elementary "module" on which we can calculate the flow field and where the velocity field in the inflow section is equal (exactly) to the velocity field in the outflow section. The flow field is repeated infinitely in space

With this kind of flow, when a material point reaches the outflow, we can continue the calculation by injecting this particle back into the inflow; the particle will travel several times the same "module"; we have thus two systems of coordinates. The first is "relative" to the coordinates in the "module". The second is "absolute" and is attached to the real trajectory in the real infinitely repeated domain.

The next picture illustrates such concepts :

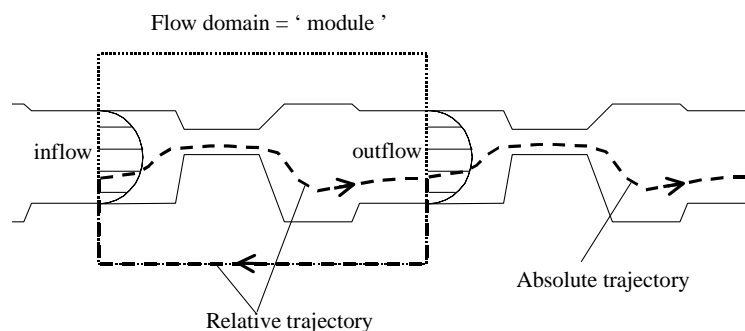



In order to calculate trajectories in spatially periodic flows, we have to connect the inflow with the outflow. A limitation of the program exists : the geometrical dimensions and the mesh distribution in the inflow and the outflow **must be equal !**

In order to define the spatially connected boundaries, first we have to select the boundary which is the entry of the flow domain and to select the correct boundary condition for them (option 3 "Entry boundary (in a spatially periodic flow)").

Then, the following message appears :

```
Current value of the number of crosses is 0
Enter its new value (CR=no modification)
```

You enter here the number of loops that the material points can do in the flow domain : the calculation of a trajectory is stopped when the material point reaches the exit after this number (or if the lifetime of this particle has expired).

In the next menu, you will specify which is the exit boundary connected with the entry :

```
*****
*                               *
*   Search of the corresponding  *
*                               *
*****

Determine in the following list which boundary
is connected to the boundary "Boundary  1"

-1 - Upper level menu                (enter -1 or CR)
# - boundary  1 is an entry of a spatially periodic flow
2 - boundary  2 is non-penetrable    (enter  2)
3 - boundary  3 is non-penetrable    (enter  3)

Select the corresponding boundary
```



Finally, you return to the previous menu that has changed like this :

```

*****
*
*   Boundary condition along boundary 1
*
*****

Current choice : Entry of a spatially periodic flow
Boundary connected to the boundary "Boundary 2" (exit)
This boundary can be crossed 5 times

Xexit(i) = A(i,j) * Xentry(j) + B(i),
where
  A(i,j) = | .0000000E+00 .0000000E+00 .0000000E+00 |
            | .0000000E+00 .0000000E+00 .0000000E+00 |
            | .0000000E+00 .0000000E+00 .0000000E+00 |
and
  B(i) = | .0000000E+00 |
          | .0000000E+00 |
          | .0000000E+00 |

-1 - Upper level menu (enter -1 or CR)
0 - Non-penetrable boundary (enter 0)
1 - Inflow (enter 1)
2 - Outflow (enter 2)
> 3 - Entry boundary (in a spatially periodic flow) (enter 3)
# - Exit boundary (in a spatially periodic flow)
-> 5 - Parameters to connect spatially periodic boundaries (enter 5)

Enter your choice

```

You have now to specify how the coordinates of the points in the entry section must be transformed to relate them with the corresponding ones in the exit section.

The general relation between points in the two sections is : $\mathbf{X}_{\text{exit}} = \underline{\underline{\mathbf{A}}} \mathbf{X}_{\text{entry}} + \underline{\underline{\mathbf{B}}}$

Select now the option 5 to specify the coefficients of the rotation matrix $\underline{\underline{\mathbf{A}}}$ and the translation vector $\underline{\underline{\mathbf{B}}}$:

```

Current value of the coefficient A(1,1) is .0000000E+00
Enter its new value (CR=no modification)
...

```





Note : When you choose the exit boundary connected to the entry boundary (of a spatially periodic flow), the boundary type of the exit boundary is automatically updated. It is not necessary to define it again.

B. Specification of a stopping plane :

Why adding stopping planes ? With this method we can save CPU time : if we are interested only in the mixing in a fraction of the domain, why do we have to spend time in calculations that are unnecessary ? By defining "stopping" planes, we have a better control on what we need. There exists another situation where it is interesting to define such planes.

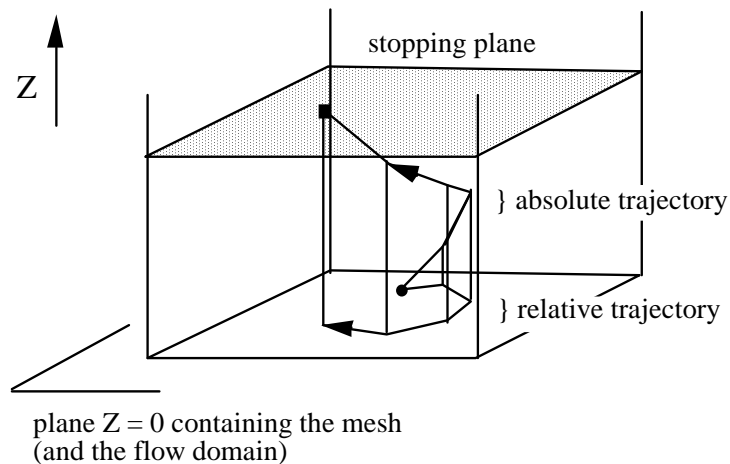
If the flow is 2D 1/2 planar, the mesh is 2D but the velocity field has 3 components (V_z is perpendicular to the mesh). For such flows, there are two systems of coordinates; the "relative" coordinates for the trajectory in the plane of the mesh, and the "absolute" coordinates in the real flow domain (3D); we continue to calculate the trajectory until the material point reaches (in the absolute system) the stopping plane :





When we select the last option of the menu "Boundary Condition", this new menu appears :

```
*****
*
*   Parameters for the stopping planes   *
*
*****

Current setup : no stopping planes

WARNING : a trajectory of a point is stopped when its position
(x,y,z) is such that  $A*x+B*y+C*z+D$  is negative.

-1 - Upper level menu                      (enter -1 or CR)
! 1 - Add a new stopping plane              (enter 1)
# - Modify the parameters of an existing stopping plane
# - Remove an existing stopping plane

Enter your choice
```

If we add a new stopping plane (option 1), we have to enter the coefficients defining the plane and the final status of the trajectory ; if the crossing of the cutting plane is valid, then select 'normal'.

```
Current value of the coefficient A of the new plane is .0000000E+00
Enter its new value (CR=no modification)

Current value of the coefficient B of the new plane is .0000000E+00
Enter its new value (CR=no modification)

Current value of the coefficient C of the new plane is .0000000E+00
Enter its new value (CR=no modification)

Current value of the coefficient D of the new plane is .0000000E+00
Enter its new value (CR=no modification)

When a point crosses this plane, the crossing is normal (y), or not (n)
Enter y(es) or n(o) (CR=yes)
```

You must be careful when defining a stopping plane : in the algorithm of trajectory calculation, after every time step of integration, we enter the current position of the material point in each plane equation, if the results are all positive then there is no crossing, and we continue the calculation. Otherwise, we stop to calculate this trajectory.



After the definition of several stopping planes, the menu has changed and appears like this :

```
*****
*
*   Parameters for the stopping planes   *
*
*****

Current setup : several stopping planes

plane id - coeff.  A,           B,           C,           D
  1      .100000E+00  .200000E+00  .300000E+00  .400000E+00
  2      .500000E+00  .600000E+00  .700000E+00  .800000E+00

WARNING : a trajectory of a point is stopped when its position (x,y,z)
          is such that  $A*x+B*y+C*z+D$  is negative.

-1 - Upper level menu                      (enter -1 or CR)
 1 - Add a new stopping plane                (enter 1)
 2 - Modify the parameters of an existing stopping plane (enter 2)
 3 - Remove an existing stopping plane        (enter 3)

Enter your choice
```

With the options 2 and 3, you can modify or delete existing stopping planes.



3.5 DEFINITION OF THE FLOW FIELD

3.5.1. STEADY STATE FLOW

For a steady state flow simulation, this menu appears like this :

```
*****
*
*   Flow Definition   *
*
*****

Current choice : filename res
                  This file is formatted

-1 - Upper level menu           (enter -1 or CR)
 1 - Enter the name of the result file (enter 1)
 # - Enter the time of use
 3 - This file is not formatted   (enter 3)

Enter your choice
```

One has just to specify the name of the result file containing the velocity field (Polyflow result file format), and if this file is formatted or not.



3.5.2. TIME DEPENDENT FLOW

For time dependant flows, the 'Flow Definition' menu is :

```
*****
*                               *
*   Flow definition             *
*                               *
*****

Continuous transient flow
Automatic selection of result files
time step = .1000000E+01
the res files are formatted
res files : from res.1 to res.10
first res file : res.2

-1 - Upper level menu                (enter -1 or CR)
  1 - Piecewise steady flow           (enter 1)
>  2 - Continuous transient flow      (enter 2)
>  3 - Automatic selection of result files (enter 3)
  4 - Manual selection of result files (enter 4)
  5 - Modify the time step             (enter 5)
  6 - Modify the prefix of the result files (enter 6)
  7 - Modify the number of result files (enter 7)
  8 - Modify the first result file id. (enter 8)
  9 - Modify the format of result files (enter 9)
# - Modify the list of result files
```

One has first to specify if the flow is piecewise steady (option 1) or continuously transient (option 2, the default).

Next, we must specify the list of result files containing the successive flow fields; two ways exist :

- In the 'automatic selection mode' (the default), the user specifies the time step (constant) between two successive flows, the prefix and the format of the Polyflow result files (one particular file for each flow), the number id of the first flow and the number of result files to be read. For example in the menu above, the flow is defined in 10 files, named res.1, res.2, ... until res.10. The prefix is 'res'. The first one is 'res.2'. The time step is 1 second between successive flows. Let's remark that all those files must exist : there cannot be holes in the numbering of the result files. If the lifetime of the material points is greater than $\text{time_step} * \text{number_of_result_files}$, we use the succession of velocity fields in a loop.
- In the 'manual selection mode', the menu changes and is now like this :



```
*****
*                               *
*   Flow definition             *
*                               *
*****

Continuous transient flow
Manual selection of result files
1 res file has been defined

-1 - Upper level menu           (enter -1 or CR)
  1 - Piecewise steady flow     (enter 1)
> 2 - Continuous transient flow (enter 2)
  3 - Automatic selection of result files (enter 3)
> 4 - Manual selection of result files (enter 4)
  # - Modify the time step
  # - Modify the prefix of the result files
  # - Modify the number of result files
  # - Modify the first result file id.
  # - Modify the format of result files
10 - Modify the list of result files (enter 10)
```

The user must specify one by one the list of Polyflow result files defining the flow (option 10).

The following menu appears :

```
*****
*                               *
*   Flow definition             *
*                               *
*****

Current setup : the velocity fields are included in the files
Index - Time of use - Filename
      1      1.00000E+20   res

-1 - Upper level menu           (enter -1 or CR)
  1 - Add a velocity field      (enter 1)
  2 - Remove a velocity field   (enter 2)
  3 - Modify the attributes of a velocity field (enter 3)
  4 - Change the order of use of the velocity fields (enter 4)

Enter your choice
```

In this menu, one can add/remove/modify the result files.

For a particular velocity field, its parameters are summarized in a menu like the next one :



```
*****
*                                     *
*   Velocity Field   i   *
*                                     *
*****

Current choice : filename res
                  This file is formatted
                  time of use = 1.00000E+20

-1 - Upper level menu           (enter -1 or CR)
 1 - Enter the name of the result file (enter 1)
 2 - Enter the time of use       (enter 2)
 3 - This file is not formatted   (enter 3)

Enter your choice
```

In this menu, we define a new velocity field : we specify in which result file is stored this field (option 1), and if this result file is formatted or not (option3). Finally, we enter the time of use of the current velocity field (option 2). If the lifetime of the material points is greater than the sum of all times of use, we use the succession of velocity fields in a loop.

Note : the 'manual selection' mode is not practical if dozen result files must be specified !



3.6 PARAMETERS FOR THE GENERATION OF THE MATERIAL POINTS

The initial screen looks like this :

```
*****
*                                     *
*   Generation of material points   *
*                                     *
*****

Current setup : no generation zones

-4 - Create a new topo-object          (enter -4)
-3 - Modify the name of a topo-object  (enter -3)
-2 - Delete a topo-object              (enter -2)
-1 - Upper level menu                  (enter -1 or CR)
! 1 - Add a new generation zone        (enter 1)
# - Modify the parameters of an existing generation zone
# - Remove an existing generation zone

Enter your choice
```

In this menu, we define zones where the material points are positioned initially. By clicking on the option 1, we define an additional zone. In order to have a well defined mixing problem, we must have one generation zone at least.

As soon as more than one generation zone is defined, a new property is added to the list of properties evaluated along the trajectories and selected in § 3.9. This new property, named "label", is constant along each trajectory and indicates the zone #id of the material point's origin.

When we have generated several zones (such as shown below), we can modify the parameters of zones or delete zones by clicking on the options 2 and 3 :



```

*****
*
*   Generation of material points   *
*
*****

Current setup : - index - intensity - generation zone
                  1         1         Box in the Flow Domain
                  2         4         Flow Domain

-4 - Create a new topo-object           (enter -4)
-3 - Modify the name of a topo-object   (enter -3)
-2 - Delete a topo-object               (enter -2)
-1 - Upper level menu                   (enter -1 or CR)
    1 - Add a new generation zone        (enter 1)
    2 - Modify the parameters of an existing generation zone (enter 2)
    3 - Remove an existing generation zone (enter 3)

Enter your choice

```

What's "index" ? The index is the identification number of the zones: the second zone is the "Flow Domain" for example.

What's "intensity" ? In the above example, we have defined two zones: every time we generate 4 points in the second zone (Flow Domain), we generate only 1 point in the first zone ("Box in the Flow Domain").

If we select the option "Add a new generation zone", the following screen appears:

```

*****
*
*   Generation Zone i   *
*
*****

Current choice : NAME           = Flow Domain
                 TOPO-OBJECT   = All the flow domain
                 INTENSITY     = 1

-1 - Upper level menu           (enter -1 or CR)
    1 - Enter the name of this generation zone (enter 1)
> 2 - This zone is all the flow domain (enter 2)
    3 - This zone is a box included in the flow domain (enter 3)
    4 - This zone is all the inflows of the flow domain (enter 4)
    5 - This zone is a topo-object (enter 5)
    6 - This zone is one inflow of the flow domain (enter 6)
    7 - This zone is a CSV slice included in the flow domain (enter 7)
    8 - Enter the intensity of the generation of points (enter 8)

Enter your choice

```



Option 1 : you can rename the new zone (optional and local to POLYDATA).

There exist different kinds of generation zones :

Option 2 : the entire flow domain. We generate randomly the initial position of material points in the flow domain; this option is well suited for flows in a closed domain.

Option 3 : we define a box by its two corners ($x_{min}, y_{min}, z_{min}$) and ($x_{max}, y_{max}, z_{max}$). This box must have a non-empty intersection with the flow domain. Two modes of generation are available. With the first one, we generate randomly the initial position of material points in the box. With the second one, called "equidistant distribution", the material points are initially distributed at equal distance d (specified by the user) between neighboring points. If the flow domain is 2D, the points are distributed at vertex positions of a lattice of identical equilateral triangles (see figure below). If the flow domain is 3D, the points are distributed at vertex positions of a lattice of equilateral tetrahedra. The generated points that are outside the flow domain will be rejected.

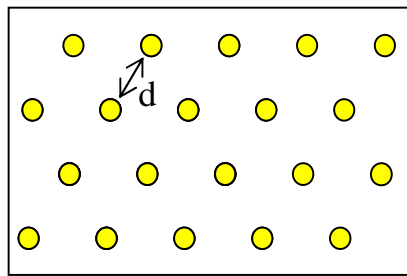

Equidistant distribution of points in a 2D box.

Option 4 : in a previous menu, we have defined the boundaries that are the inflows of the flow problem. With this option, we generate randomly the initial position of material points in these entries; this option is well suited for flows in an open domain.

Option 5 : with this option, we can define a zone by selecting a topo-object in a list. If some topo-object is missing, it is possible to add new ones in the list (see note on next page).

Option 6 : in a previous menu, we have defined the boundaries that are the inflows of the flow problem. With this option, we select one inflow section among the boundaries tagged as "inflow" in the "boundary conditions" menu. We generate randomly the initial position of material points in the selected entry; this option is well suited for flows in an open domain.

Option 7 : with this option, the user can specify its own initial distribution of points, saved in a CSV file (Comma Separated Variables format). After selecting this option, the user introduces the name of the CSV file. Then, a question appears to the screen:

"All fields are reinitialized to default values. Do you agree with that?"



if you enter "yes", that means that we just read the coordinates of the points in the CSV file; the other properties will be reinitialized to their default values : time ← 0; logarithm_of_stretching ← 0; space_integration ← 0; ..

if you enter "no", that means that POLYFLOW will read not only the coordinates of the points in the CSV file, but also some other properties. If they are found, we initialize the property with the value found in the file, otherwise we initialize with the default values, as usual. The properties that are read in the CSV file are (the coordinates must be the first property written in the file) :

"COORDINATES" (in upper case, with always 3 components)
"time" "logarithm_of_stretching"
"space_integration" "direction_of_stretching"
"label"

All the points defined in the CSV file that are included in the flow domain will be tracked; the other points are rejected.

Another use of this option is the following: let us assume you cut your flow simulation in several parts, to simplify and reduce the size of the problem: the flow on each part is evaluated separately. Then, you want to make some tracking of material points across all the parts. You define a first tracking through the first flow part. Next, with the generated mixing files, in POLYSTAT you perform a slicing at the exit of the first flow domain; save the slice in a CSV file. Next, you can define a second mixing task in POLYDATA, on the second flow part; the generation zone will be the CSV file you created in POLYSTAT. By this way, you will pursue the tracking in the second flow part. In this case, it is useful to answer "no" to the question "All fields are reinitialized to default values. Do you agree with that?" in order to keep the history of deformation and stretching throughout the whole flow domain.

Option 8 : You have also the ability to generate with a higher frequency points in one zone in comparison with others; to do that, you modify the intensity factor of the created zones : higher the intensity, higher the frequency of point generation in that zone.



Note 1: If among the generation zones, some of them are of the 'CSV file' type, it is mandatory to impose the intensity of each zone equal to the number of material points starting from that zone. Then in the "Storage of results" menu (§3.10), ensure that NBPTMX * NBFIL ("the number of material points per file" times "the number of files") is equal to the sum of the intensities.



Note 2: If among the generation zones, some of them are of the 'BOX with equidistant distribution' type, it is difficult to estimate the exact number of points that will eventually be generated in that zone. That is why an approximation of the number of points (upper bound) that will be generated is provided to the user when defining the "box" generation zone. This number can be used to define appropriately the intensity of generation, nbptmx and nbfile, as for previous note 1.



Note on the definition of topological objects :

The management of topo-objects is done in the menu "Generation of the material points".

To **create a new topo-object**, select "Create a new topo-object" option in the menu "Generation of the material points". The following menu appears :

```
*****
*
*   Add topo-objects   *
*
*****

object 1 = S1*B5
object 2 = S2*B4
operator = INTERSECTION

-2 - Reset                (enter -2)
-1 - Upper level menu    (enter -1 or CR)
 1 - Select object 1     (enter 1)
 2 - Select object 2     (enter 2)
 3 - Select UNION operator (enter 3)
# - Create new object

Enter your choice
```

The user must select two existing objects in a list and one operator (UNION or INTERSECTION). When this is done, he selects option "Create a new object", and specifies the name of the new topo-object (see menu above).

Let us mention that object like $S1*B5$ means intersection of subdomain $S1$ and boundary $B5$.

Be cautious, if one uses 'INTERSECTION' operator, the resulting object may be empty ! There is no check to avoid that situation : running POLYFLOW with this kind of degenerated generation zone will lead to a fatal error !

In order to **modify the name of a topo-object**, select "Modify the name of a topo-object" option in the menu "Generation of the material points". Then, select one existing object in the list. Eventually, select option "Modify object name" and enters a new name for this object.

In order to **delete a topo-object**, select "Delete a topo-object" option in the menu "Generation of the material points". Then, select one existing object in the list. Eventually, select option "Delete object" to delete effectively the selected object.



3.7 PARAMETERS FOR THE TRACKING

In order to calculate the trajectory of a material point, we have to specify a set of numerical parameters. These parameters have different purposes : to decide when to stop the calculation, when there is a problem, ... The initial screen looks like this :

```
*****
*
*   Parameters for the tracking   *
*
*****

Current setup :
TIMAX, the lifetime of the material points = 1.0000000E+04
VNORMX, the maximum velocity in the flow field = 1.0000000E+00

-1 - Upper level menu      (enter -1 or CR)
! 1 - Modification of TIMAX (enter 1)
! 2 - Modification of VNORMX (enter 2)
  3 - Options              (enter 3)

Enter your choice
```

You have to modify **absolutely** the two parameters TIMAX and VNORMX :

1.- TIMAX is the lifetime (in seconds) of the material points; we will calculate their trajectory until that time is reached. In order to lower the CPU time of your simulation, don't put a huge value for this time if it is not necessary.

2.- VNORMX is the maximum velocity magnitude in the flow field. It will serve to detect stagnation points in the flow : a stagnation point is a point that has a negligible velocity in comparison with the maximum velocity. By default, 'negligible' means one millionth of the maximum velocity.

By selecting option 3, the user can modify some numerical parameters acting on the accuracy of the integration scheme.



```
*****
*
*   Parameters for the tracking   *
*
*****

Current setup :
NBELEM, the number of steps of integration
to cross an element of the mesh      = 3
EPSPNT, the tolerance criterion on a distance = 1.0000000E-06
EPSVIT, the tolerance criterion on a velocity = 1.0000000E-06
EPSTIM, the tolerance criterion on a time   = 1.0000000E-06

-1 - Upper level menu      (enter -1 or CR)
 1 - Modification of NBELEM (enter 1)
 2 - Modification of EPSPNT (enter 2)
 3 - Modification of EPSVIT (enter 3)
 4 - Modification of EPSTIM (enter 4)

Enter your choice
```

1.- NBELEM : This parameter indicates how many integration steps we want to cross one element of the finite element mesh : the default (3) asks that, in the mean, any material point crosses one finite element in 3 steps. This parameter is important for the accuracy of the calculation of kinematic parameters (higher is NBELEM, better is the accuracy). It's not necessary to have NBELEM higher than 3 (expensive in CPU time, and intrinsic accuracy of the method reached).

2, 3 and 4.- EPSPNT, EPSVIT and EPSTIM are respectively tolerances on a distance, on a velocity and on a time. Two points are identical if the distance between these points is smaller than EPSPNT. EPSVIT is used to determine if a point is a stagnation point : if the local velocity $v(X,t)$ is lower than $EPSVIT * VNORMX$, then the material point X , at time t is a stagnation point. A time step smaller than EPSTIM is considered as zero; it will be used to stop the iterative Newton-Raphson procedure that finds the time step needed to reach the border of the current finite element containing the point.

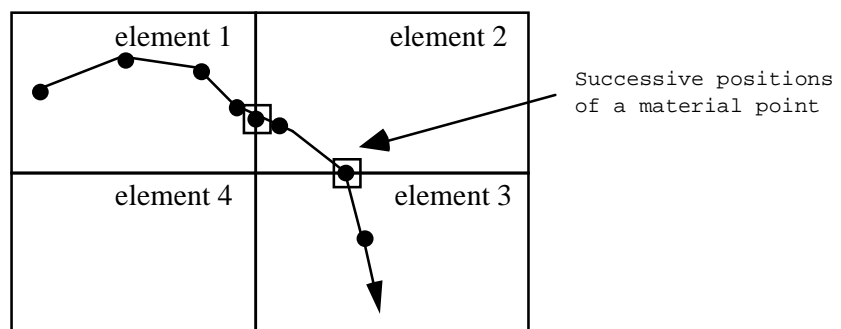



Remember that we calculate the trajectory of a material point piece by piece : we integrate the velocity in a finite element until we reach the border of this element. Then we find the adjacent element where to continue the calculation, and so on ... It is thus important to determine precisely the time step needed to reach the border of the current element containing the material point.

3.8 PARAMETERS FOR THE KINEMATIC MIXING PROPERTIES

The initial screen looks like this :

```
*****
*
*   Parameters for the kinematic variables   *
*
*****

Current setup : - Random initial direction of stretching
                - No constraint over the tensor F

-1 - Accept the current setup                (enter -1 or CR)
> 1 - Random initial direction of stretching (enter 1)
  2 - Imposed initial direction of stretching (enter 2)
> 3 - No constraint over the tensor F        (enter 3)
  4 - Constraint over the tensor F : detF = 1 (enter 4)

Enter your choice
```

As a material point moves in the flow, a small volume of matter attached to it will deform. To calculate its stretching and its rate of stretching, we have to specify a direction where to measure this stretching (as explained in the theoretical background). We have two possibilities (options 1 and 2) :

1.- We don't specify a direction : the computer will generate randomly an initial direction of stretching. This direction will be different from material point to material point.

2.- We specify a direction (dx,dy,dz) : every material point has the same initial direction.

The two possibilities are in fact equivalent after a while in a statistical point of view.

The second parameter to define is about the way we calculate the tensor F , the gradient of deformation tensor.

For 2D simulations, no problems, the method guarantees that the determinant of F will remain 1 (incompressibility); it has no influence if you select option 3 or 4.



But for 3D flows, we cannot be sure that the tensor \mathbf{F} will remain 1 along a trajectory of a material point. If we do not constraint the tensor \mathbf{F} , a future analysis of the results in POLYSTAT will show if the calculations were accurate (if $\det \mathbf{F}$ remains 1 along the trajectories). In the other case, unfortunately, if we constraint \mathbf{F} , such that $\det \mathbf{F}$ remains 1 along trajectories, we cannot be sure that this will improve the accuracy of the results. That is why we prefer not to constraint \mathbf{F} (default).

3.9 SELECTION OF PROPERTIES

The initial screen looks like this :

```
*****
*
*   Selection of properties   *
*
*****

List of selected properties :
- Time      (always)
- Coordinates (always)

-1 - Upper level menu      (enter -1 or CR)
 1 - Enable Space integration (enter 1)
 2 - Enable Rate of stretching (enter 2)
 3 - Enable Rate of dissipation (enter 3)
 4 - Enable Direction of stretching (enter 4)
 5 - Enable Logarithm of stretching (enter 5)
 6 - Enable Pressure (enter 6)
 7 - Enable Velocity (enter 7)
 8 - Enable Temperature (enter 8)
 9 - Enable Divergence of velocity (enter 9)
10 - Enable Determinant of F (enter 10)
11 - Enable Viscosity (enter 11)
12 - Enable Mixing index (enter 12)
13 - Enable First eigenvalue of T (enter 13)

Enter your choice
```

With this menu, we select in a list the properties we want to store in the result mixing files. The time and the coordinates are always saved.



The first property, the space integration $S(t)$, is the length of the trajectory up to the current time t :

$$S(t) = \int_{t_0}^t |v(t')| dt'$$

The properties 2 to 5 are the kinematics parameters defined in Chapter 2 :

a) for 2D flows :

- i. the rate of stretching is equal to $\dot{\lambda}/\lambda$,
- ii. the rate of dissipation is equal to D ,
- iii. the direction of stretching is the vector \mathbf{m} ,
- iv. the logarithm of stretching is the *natural* logarithm of λ .

b) for 3D flows :

- i. the rate of stretching is equal to $\dot{\eta}/\eta$,
- ii. the rate of dissipation is equal to D ,
- iii. the direction of stretching is the vector \mathbf{n} ,
- iv. the logarithm of stretching is the *natural* logarithm of η .

The properties 6 to 8 are based on the fields stored in the RES files needed for the tracking : pressure, velocity and temperature are coming from the flow calculation. If those fields are not in the RES files, they are initialized to zero.

The properties 9 and 10 are useful to evaluate the accuracy of the calculation.

The properties 11 to 13 are based on fields stored in the RES files needed for the tracking : viscosity, mixing index and first eigenvalue of tensor T are post-processors defined as additional sub-tasks to the flow calculation. If those fields are not in the RES files, they are initialized to zero. Those three fields are especially useful to the analysis of the **dispersive mixing**. The mixing index M indicates if locally the flow is 'rigid' ($M = 0$), or is a shear flow ($M = 0.5$), or is an extensional flow ($M = 1$). Moreover, the first eigenvalue of the extra-stress tensor T indicates the local stress (important parameter to evaluate the capillary number).

Select only the properties that are necessary ! You will save time and memory.



3.10 PARAMETERS FOR THE STORAGE OF THE RESULTS

The initial screen looks like this :

```
*****
*
*   Storage of the results   *
*
*****

The current values of the parameters are

PREFIX, the prefix of the result files      = mixing
NBFILE, the number of results files        = 999
The result files are formatted
NBPTMX, the maximum number of trajectories
        in a single result file            = 100
CPUMAX, the maximum CPU time (in hours)
        to generate a single result file    = 4
We store the successive positions of the material points
at each time step of 1.0000000E+00 seconds

-1 - Upper level menu                      (enter -1 or CR)
 1 - Modification of PREFIX                 (enter 1)
 2 - Modification of NBFILE                 (enter 2)
 3 - The result files are unformatted       (enter 3)
 4 - Modification of NBPTMX                 (enter 4)
 5 - Modification of CPUMAX                 (enter 5)
 6 - Storage of all the points of the trajectories (enter 6)
> 7 - Storage at each time step (exactly)   (enter 7)
 8 - Storage after each time step (minimum) (enter 8)
 9 - Storage at each displacement (exactly) (enter 9)
10 - Storage after each displacement (minimum) (enter 10)
!11 - Modification of the time step         (enter 11)
```

With this menu, we will determine the way we store the calculated trajectories and the evolution of different properties. These results can be stored in several files in order to be analyzed by POLYSTAT.

Options 1 to 3 : the prefix of the files is by default "mixing". We will create files with the names "[prefix].000i", where i varies from 1 to NBFILE, which is the number of files to generate. With the option 3, you can choose if the files are formatted (ASCII mode readable by human beings and all machines) or not. Despite the fact that the unformatted files are smaller in size (economy of memory space), the default option is "formatted".



Options 4 and 5 : NBPTMX and CPUMAX are parameters that allows the user to specify the way POLYFLOW will generate the files. NBPTMX is the maximum number of trajectories that are stored in a single result file. CPUMAX is the maximum CPU time (in hours) that is spent before we close the current file and we begin to store results in the next file.

By this way, we generate continuously files : we can begin the statistical analysis (on a short population of material points) and in the same time, POLYFLOW continues to work. If we are happy of our results, we can interrupt POLYFLOW. If we want, we can run again POLYFLOW with the same data file; it will begin to generate a new result file without erasing the result files from an old session.

Options 6 to 10 : we have to select one of these five ways to store trajectories. With the option 6, we store every calculated position (very expensive on a memory space point of view). Option 7 allows the user to store the successive positions of a material point every DT seconds exactly. With option 8, two successive stored positions have a minimal time step of DT seconds. The time step DT is imposed in option 11. With option 9, we store a position every time the length of the trajectory has increased of a distance DL. With option 10, we store a new position if the increase (*) in the trajectory length is greater than DL. The displacement DL is imposed in option 11.

If you select option 9 or 10, option 11 becomes :

!11 - Modification of the displacement	(enter 11)
--	------------

and you can modify the exact or minimum displacement to move before we store the actual position of a point.

(*) The increase in that case is the difference between the trajectory length for the current stored position and the trajectory length for the previous stored position.



3.11 DEFINITION OF MOVING PARTS

The initial screen looks like this :

```
*****
*                                     *
*   Define moving parts               *
*                                     *
*****

-2 - Deletion of a moving part      (enter -2)
-1 - Upper level menu                (enter -1 or CR)
 0 - Creation of a new moving part  (enter 0)

Enter your choice
```

With this menu, we specify the moving parts (if any) overlapping the flow domain. Those data are used to remove particles generated randomly in the flow domain and also included in a given moving part.

Caution : you must specify the moving parts in the SAME order as in the previous flow task !

First, we have to 'create' it (option 0). The following menu appears :

```
*****
*                                     *
*   moving part #1                   *
*                                     *
*****

-1 - Upper level menu                (enter -1 or CR)
 1 - Definition of the moving part domain (enter 1)
 2 - Modification of title           (enter 2)

Enter your choice
```

For this moving part, we specify its domain (option 1) and its name (option 2).



CHAPTER 4

THE POLYSTAT USER'S MANUAL

After the calculation of a large set of trajectories (performed with POLYFLOW), we have to use POLYSTAT in order to treat and / or visualize those results to obtain a global overview of the mixing process in the current flow.

To perform such statistical treatment several steps must be performed in a specific order : the main menu of POLYSTAT appears as follows and shows these steps ⁽¹⁾ :

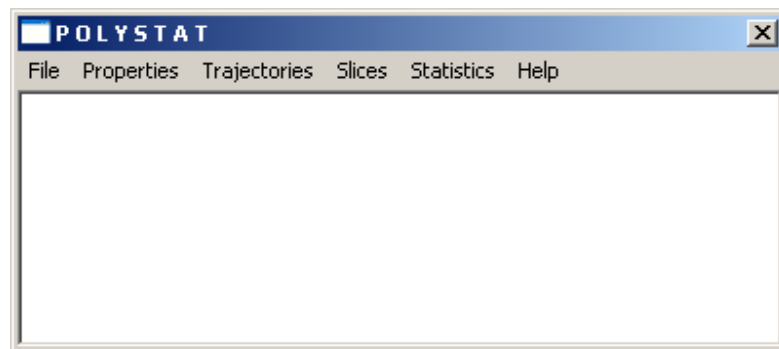

The major steps are the following :

- 1) in the menu "FILE", we read the results generated by POLYFLOW (the data necessary to POLYSTAT).
- 2) in the menu "PROPERTIES", we can ask the program to calculate new parameters evolving along the trajectories. For example, we can define any concentration field, or a new mixing index. These new parameters are always a combination of existing parameters (those calculated in POLYFLOW and stored in the mixing result files). We will see later the different possibilities accessible to the user.
- 3) in the menu "TRAJECTORIES", we have the ability to select a subset of trajectories on which we will perform the statistical treatment. For example, we can eliminate all the trajectories that terminated abnormally (on a wall, for example). We will see later the different possibilities accessible to the user.

⁽¹⁾ The Help option summarizes this analysis process and gives information on the way to contact us if necessary (telephone, Email and fax number).



- 4) in the menu "SLICES", we determine the way to "slice" the selected trajectories. For example, let's suppose that we analyze the flow through a cylinder, like shown on the next picture :

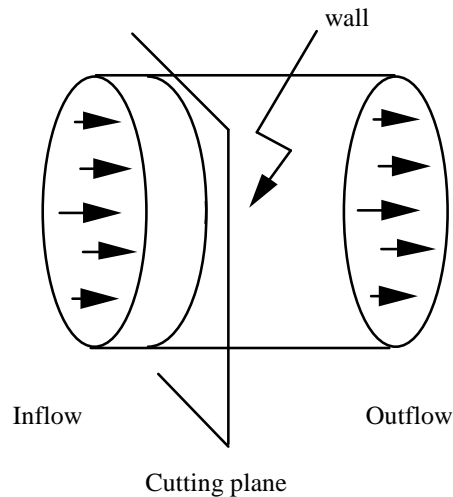

To analyze this flow, we place a set of material points in the inflow section, and we calculate their trajectory until they reach the outflow section. We will cut the trajectories with planes disposed regularly from the entry to the exit (this is the slicing step). In each plane, we will calculate statistical functions. Those functions will evolve from entry to exit, and show the way the mixing changes.

Remark : **if the flow occurs in a closed domain**, we want to know the time evolution of statistical functions and **the slicing will be done on the time**.

- 5) in the menu "STATISTICS", we define the set of statistical functions we want to calculate on the defined set of slices.
- 6) finally, we go back to the "FILE" menu, and click on the "RUN" option. By clicking on this option, we order POLYSTAT to calculate actually all our desiderata (new properties, the subset of trajectories, the set of slices, the set of statistical functions). This calculation can last for a while ... When the calculation is over, we can analyze, visualize and store our results.

After this brief description of the way to use POLYSTAT, we will now explain in detail every menu, option and window.



4.1 THE FILE MENU

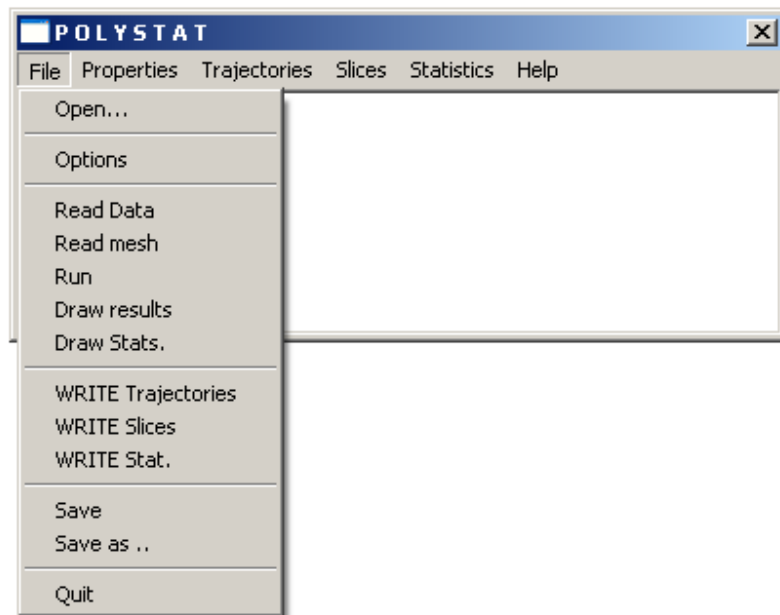

The "Open .." option allows you to read an old POLYSTAT session file.

The "Options" allow you to specify some parameters for reading trajectories, for slicing and for visualization.

The "READ data" option allows you to read the files containing the trajectories calculated by POLYFLOW. All the trajectories and the kinematic parameters calculated along those trajectories are stored in POLYSTAT.

The "READ mesh" option allows you to read the file containing the finite element mesh (Polyflow format) used to calculate the flow and the trajectories. This mesh is used only by the option "DRAW results" to visualize a property in a slice through the flow domain.

By clicking the "RUN" option, you ask for the calculation of all the objects defined earlier (new properties, new sets of trajectories, new sets of slices, new statistical functions).

With the "DRAW results" option, you can visualize one selected slice/trajectory in the flow domain : you will see the spatial repartition of any property in this slice/trajectory. The drawings can be saved in Postscript files.



With the "DRAW stat" option, you can visualize the calculated statistical functions and save them in Postscript files.

With the "WRITE trajectories" option, you select a set of trajectories to save on files (in the "csv" file format, see Polyflow User's Manual for more details).

With the "WRITE slices" option, you select a set of slices to save on files (in the "csv" file format, see Polyflow User's Manual for more details).

With the "WRITE stat." option, you select statistical functions to save on files (in the "crv" file format, see Polymat User's Manual for more details).

The "Save .." option allows you to save your current POLYSTAT session.

Finally, to quit the program, click on the "QUIT" option, and confirm your choice.

4.1.0 THE "OPEN .." OPTION

This option allows you to read a file (with a "sav" suffix) containing a previous POLYSTAT session. By this way, it is possible to pursue an interrupted session on the same set of mixing files or to apply same statistical treatment on a new set of mixing files (in this case, the mixing files must have same name, same type (ascii or binary) and with the same number of mixing files). See section 4.1.9 for additional information on the list of objects saved (or not saved) in the POLYSTAT session file.

4.1.1 THE "OPTIONS" OPTION

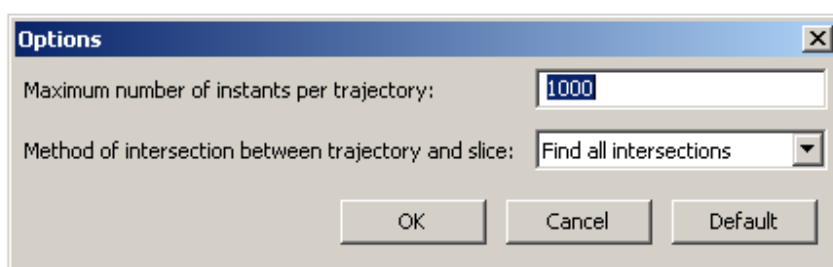

This option allows you to specify some parameters :

- The maximum number of instants per trajectory : default value =1000. If a trajectory has more instants than this maximum, we interpolate the properties along the trajectories in order to limit the instants to that number. It may be useful to increase this number, if one knows that some trajectories are very long and have much more instants stored in the mixing file.



- The method of intersection between a trajectory and a slice : by default, we compute all the intersections. This may cause some bias in the statistical functions, if one performs a slicing in a space direction and if there are backflows. In that case, it is mandatory to use the "Find first intersection" method.

4.1.2 THE "READ DATA" OPTION

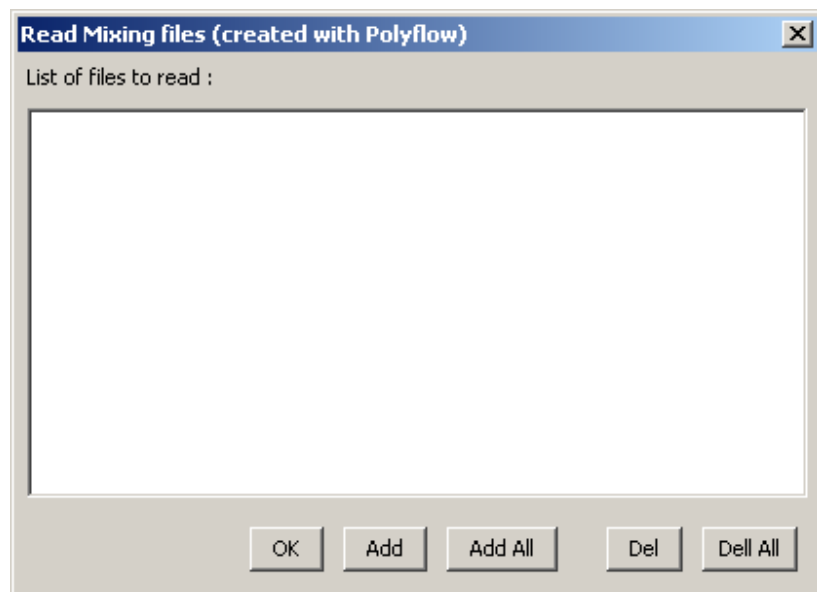

This window shows the list of mixing files already read.

If you want to add several mixing files to the list in a single command, click on the "Add all" button : the following window will appear :

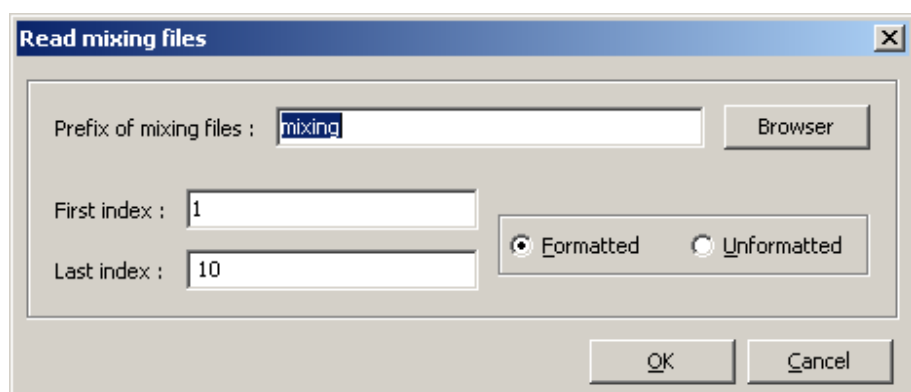



In this window, the user has to specify the prefix of the mixing files, their first and last indexes and their format. If the mixing files are not in the current directory, click on the "Browser" button to search their location with a specific file browser. The names of the mixing files are built like this : [prefix].[000i], where 'i' is the current index. Once those data are entered, click on the "OK" button to close the window and actually read the mixing files. Click on "Cancel" to close the window without any reading !

If you want to add just one file, click on the "Add" button : a file browser will appear in which you have to select the file. It is not possible to read the same file twice. When a file has been selected, a new window appears asking if this file is formatted or not; don't make any mistake, because a wrong answer can unfortunately interrupt definitively your session !

It is possible to remove from the list one, several or all the files. To remove one file from the list, select it in the list, and then click on the "Del" button. To remove all the files, click directly on the "Del All" button. In both cases, POLYSTAT asks for a confirmation of your choice. If there are no file in the list, it is impossible to do anything with POLYSTAT, of course !

If the current list seems complete to you, click on the "OK" button, and you will go back to the main window.

4.1.3 THE "READ MESH" OPTION

When you click on this option, the following window appears :

Read a mesh file

Initial mesh :

Formatted Unformatted

Moving parts motion ?

Yes No

Prefix of result files :

First index : Formatted Unformatted

Last index : Formatted Unformatted



In the upper part of the window, just enter the name of the mesh file (Polyflow mesh format) and its format. If the file is not on the current directory, click on the "Browser" button : a file browser appears in order to search the location of the file.

In the lower part of the window, you can enter specific data in order to visualize later the motion of moving parts (calculated with the mesh superposition technique in a previous POLYFLOW run). First, answer 'yes' to the question "Moving parts motion ?" Next, enter the prefix of the result files (Polyflow result files) in which are stored the successive flow fields, enter also the number N of those files (in the "last index" input area). Finally specify the format. The result file names will be built like this : [prefix].[id], where 'id' ranges from 1 (first index) to 'n' (last index).

The 'OK' button is used to close the window and read the files. The 'Cancel' button closes the window without any reading. The 'Reset' button reinitializes the internal data structure containing the mesh and the successive positions of the moving parts.

Note 1 : Don't make any mistake in the format of the files, because a wrong answer can interrupt definitively your session !

Note 2 : It is absolutely necessary to read a mesh before any visualization of your results.

4.1.4 THE "RUN" OPTION

By selecting the "RUN" option, you want to actually calculate all the objects you defined elsewhere (properties, trajectories, ...). But, it takes time ...

That is why, firstly, you will have to confirm your choice :

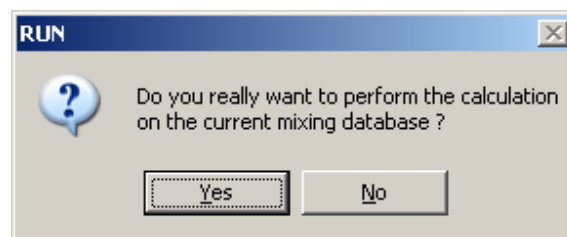

If you confirm your order, POLYSTAT will calculate successively the new properties, the new sets of trajectories, the sets of slices and the statistical functions. Upon the time, a message informs the user about the current calculations being done.

When those calculations are finished, we can visualize our results; it's the purpose of the next paragraph.



4.1.5 THE "DRAW RESULTS" OPTION

With this option, we can see the results of our calculations : we visualize in the flow domain the spatial distribution of a property for a specific slice or for a given trajectory. By clicking the "DRAW results" option, a new window will appear; on the left side, in the Graphic Options window, one can specify what to see in the right part of the window (the Graphics Display window). One can also find a graphics toolbar above the graphics display: this graphics toolbar contains a set of buttons that allows you to manipulate the view displayed in the Graphics Display window (see paragraph 2.8 "Graphics Toolbar" of the POLYFLOW User's Guide for more information about the use of these buttons).

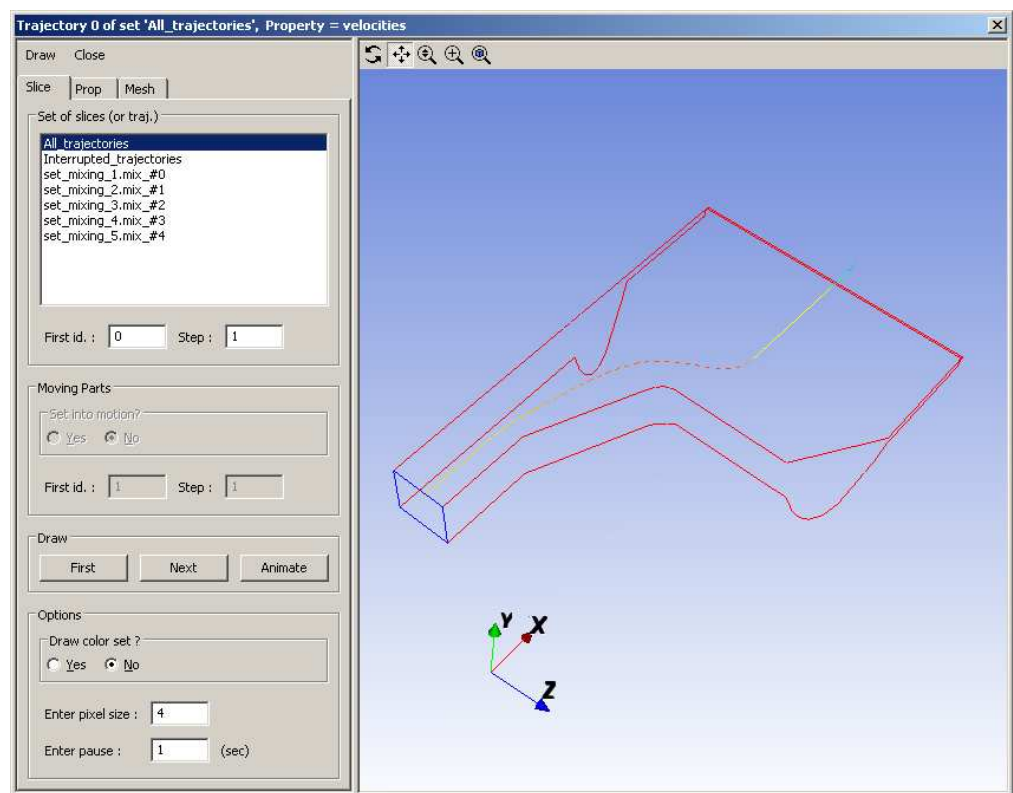

Graphic window of POLYSTAT

In the Graphic Options window, there exist two zones : in the first one, two buttons (Draw and Close) are placed; in the second one, we can see three pages (Slice, Prop and Mesh).

First, let's explain the use of every button :

- 1) The button "Draw" : this button allows you to update the drawing with the current set of options selected by the user.



- 2) The button "Close" : with this option, we close the graphic window; the current graphic options are saved.

Now, let's explain the three "pages" of the Graphic Options window.

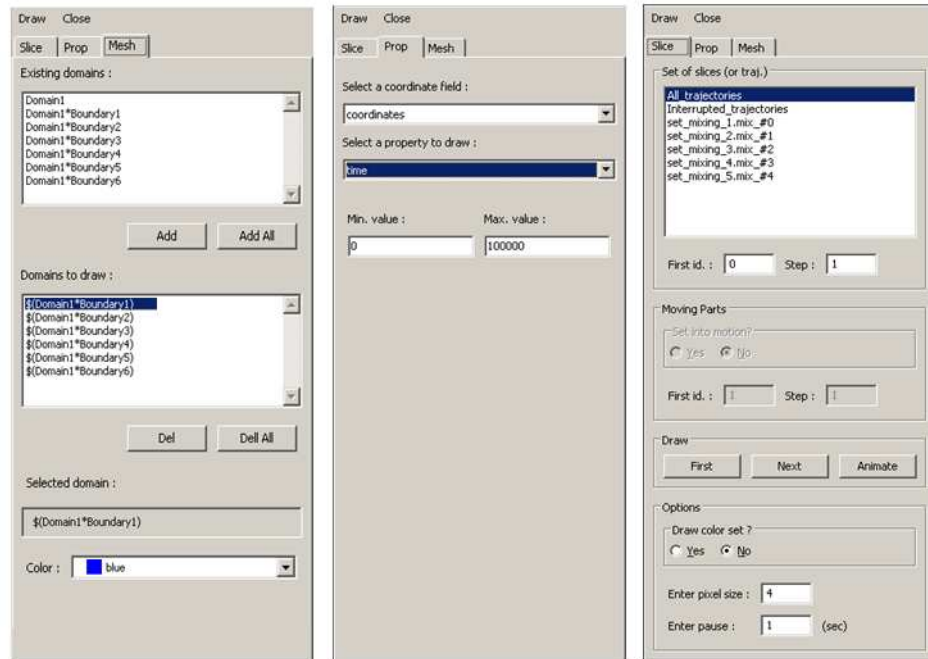

Go in the three pages in the following order:

- 1) in the page "mesh", you have to specify the parts of the mesh you want to see :

In the upper part of the page "Mesh", the list of existing domains is shown. A domain is a topological object based on the mesh. The following objects are built automatically: a) the domains, b) an intersection of a domain with another domain (for example, the intersection between the domains 1 and 2 is written Domain1*Domain2), c) an intersection of a domain and a boundary (for example, the intersection between the domain 1 and the boundary 3 is written Domain1*Boundary3), d) the perimeter of the previous objects (the perimeter of Domain1*Boundary3 is written \$(Domain1*Boundary3).

If you want to visualize a domain of this list, click on its name. Then, click on the "Add" button; the selected domain will disappear from this list and appear in the list named "Domains to draw". In this list, you can see the set of domains to visualize. If you want to change the color of one domain, click on its name in the list of domains to draw (selection); its name now appears in the box "Selected domain" as well as its current color in the box "Color". This color can be changed by clicking on the button "↓".



If you don't want to see a domain, click on its name in the list of the domains to draw (selection), then click on the button "Del". If you click on the button "Del All", all the domains will disappear. If you want to see all the domains, then click on the button "Add All".

- 2) in the page "Prop", you have to specify the property you want to see on the slices or along the trajectories :

Next, in the page "Prop", select a coordinate field (used to position the pixels or the segments in the domain), and a property to draw. Once a property is chosen, you can see the range of values for this property (in boxes named "min. value" and "max. value"). If it is a vector field, the range is based on the norm of the field. You have the ability to change this range of values if needed.

- 3) in the page "Slice", you have to specify the set of slices or trajectories you want to visualize. You can also specify a possible link between successive slices and successive positions of moving parts :

In the page "Slice", select first a set of slices (or a set of trajectories), second a first slice (or trajectory) index of this set. If you want to see successive slices (or trajectories), enter also a positive increment (step). Then, click on the button 'First': the first slice (or trajectory) is drawn in the graphic display. Now, each time you click on the 'Next' button, the current slice (or trajectory) is increased by the step, so that we can analyze easily the complete set. If we want to avoid to click again and again on the 'Next' button, click on the 'Animate' button: all will be automatic. In that case, do not forget to specify a pause (in second) corresponding to a waiting time between two successive drawings. Once the animation is started, the button "Animate" changes to "Stop" ; if selected, the animation is interrupted.

If the mesh superposition technique has been used in POLYFLOW to calculate a flow with moving parts, it is possible to see the location of those moving parts at different time steps. To do so, select 'yes' to the question "Set into motion?" Then select the first position of the moving parts corresponding to the first slice of your set of slices. Enter also an increment (step) for the successive positions of the moving parts you want to look at. Then, click on the button 'First': the first slice and the first position of the moving parts are drawn in the graphic display. Now, each time you click on the 'next' button, the current slice is increased by the slice step, and the current moving parts position is increased by the moving parts step. The motion of the moving parts is now linked to the successive slices of the current set. The user has the responsibility to define the correct set of slices corresponding to the motion of the moving parts: he has to define an automatic slicing on time, with an increment corresponding to the time step existing between two successive positions of the moving parts. He has also to choose correctly the first slice, the first moving parts position, step slice and moving parts step. The default values are rarely correct!

Eventually, in the page "Slice", you can select the pixel or segment size (logarithmic scale). Moreover, if you answer 'yes' to the question "Draw the color set?", the color scale is displayed in the right side of the "Graphics Display" window.

Moreover, there exists a series of shortcuts that can be used for modifying the graphic window. Typically, they can be invoked for modifying the appearance of object, the axes, the background colour and the view point. They can be easily invoked when the graphic window is active. The list of keys is the following:



Appearance:

- s : displays topological objects in shaded mode.
- w : displays topological objects in wireframe.

Axes:

- a : removes axes from display.
- A : adds axes to display.

Background:

- b : sets background colour to light blue.
- B : sets background colour to black.
- W : sets background colour to white.
- G : sets background colour to grey.

Resize:

- r or R : fits display into window.

Views:

- x : view perpendicular to YZ plane from positive x coordinate.
- y : view perpendicular to XZ plane from positive y coordinate.
- z : view perpendicular to XY plane from positive z coordinate.

4.1.6 THE "DRAW STAT." OPTION

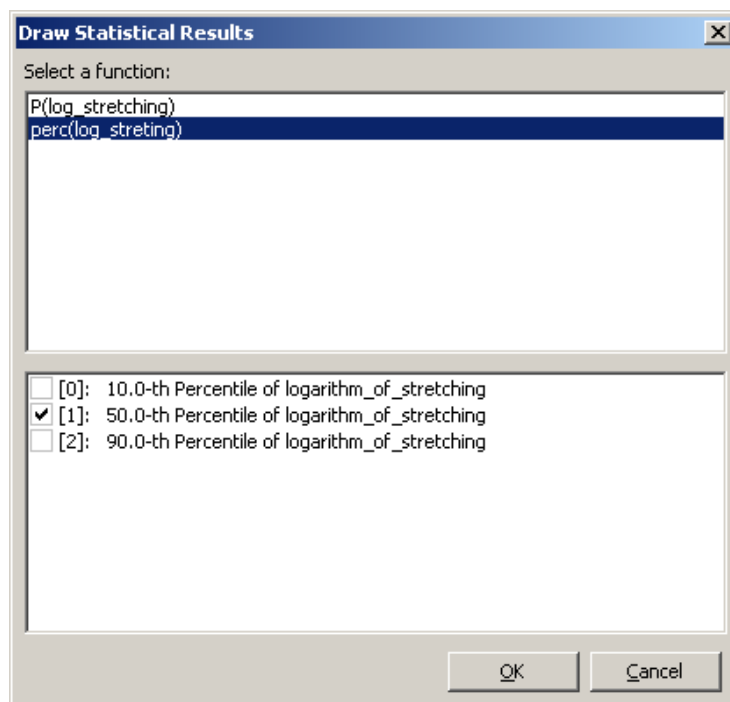

In this window, you will select the functions you want to visualize with POLYCURVE. POLYCURVE is a charts editor linked to POLYSTAT : its main goal is to allow the user to create and visualize charts (see the chapter 8 of the POLYMAT User's Guide, for a complete description



of POLYCURVE). A chart can contain several curves. We can add and remove a curve, change a title, a color, the range of the axes, ...

First, you select one function in the upper list. The corresponding set of curves are displayed in the lower list. Then, tick the curves you want to display. Eventually, click on the "Ok" button. Then, every ticked curve is "sent" to POLYCURVE; a chart is automatically created to present them, as can be seen in the next figure. If you want now to visualize curves of another function in another chart, then in the POLYCURVE window, click on the button "New Chart". Next, click on the button "Statistics"; the "Draw Statistical Results" window opens and you can select another statistical function and another set of curves, as explained above. The "Close" button allows you to close the POLYCURVE window and to go back to the main POLYSTAT window.

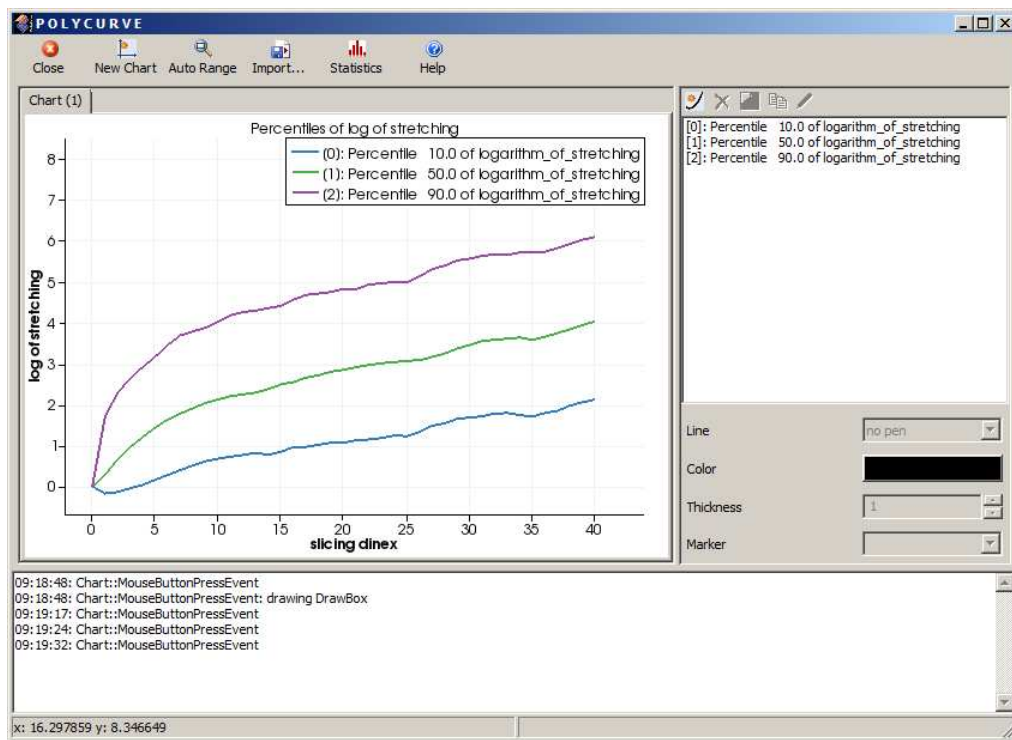

Example of chart displayed in POLYCURVE.



4.1.7 THE "WRITE TRAJECTORIES" OPTION

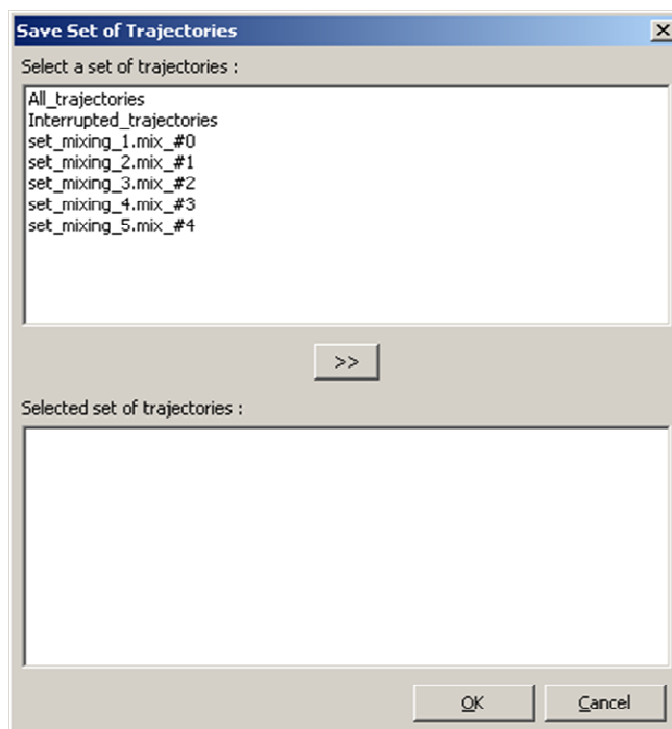

In this window, you will select the set of trajectories you want to save in formatted files. First, you select one set in the upper list. Then you click on the ">>" button. The next window appears:

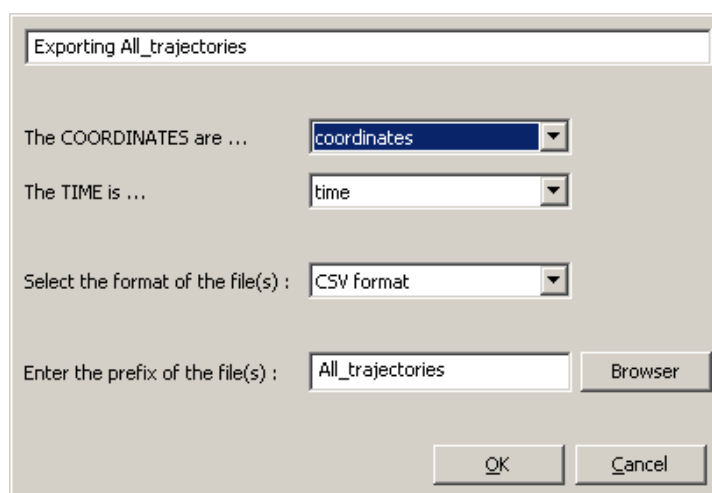



You have now the ability to choose the coordinates and time to be used (useful in some case where absolute and relative coordinates exist, or if you defined your own coordinates or time).

You can also select the format of writing:

a) The default format is “CSV format”. One saves the selected set of trajectories in a set of CSV files. The CSV file format (see POLYFLOW User's Manual) is a common format for tabulated data that can be read into spreadsheet programs such as Excel. POLYSTAT will generate one file per trajectory : their names are built like this :

[prefix]_[trajectory index].csv

b) The second format is the “FV format”. One saves the selected set of trajectories in a single “FVP” file, that can be loaded in FieldView. This option is useful if your simulation is steady state and if you want a better graphic treatment of your trajectories (for transient simulations, see § 4.1.7). POLYSTAT will generate one file with the name :

[prefix].fvp

c) The last format is the “CFD-Post format”. One saves the selected set of trajectories in a single “TRK” file, that can be loaded in CFD-Post. This option is useful if you want a better graphic treatment of your trajectories. POLYSTAT will generate one file with the name :

[prefix].trk

Enter now the prefix of the files to generate, or select it with the browser (click on the “browser” button).

After the writing, the set of trajectories already written appear in the list named “Selected set of trajectories” of the window “Save Set of Trajectories”. When you have finished, click on the "OK" button in this window to go back to the main window.



4.1.8 THE "WRITE SLICES." OPTION

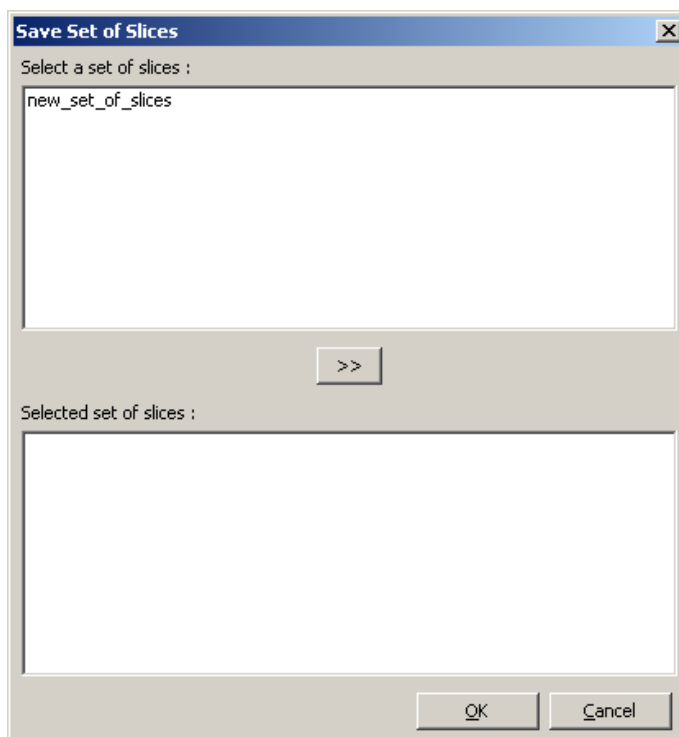

In this window, you will select the set of slices you want to save in formatted files. First, you select one set in the upper list. Then you click on the ">>" button. The next window appears:

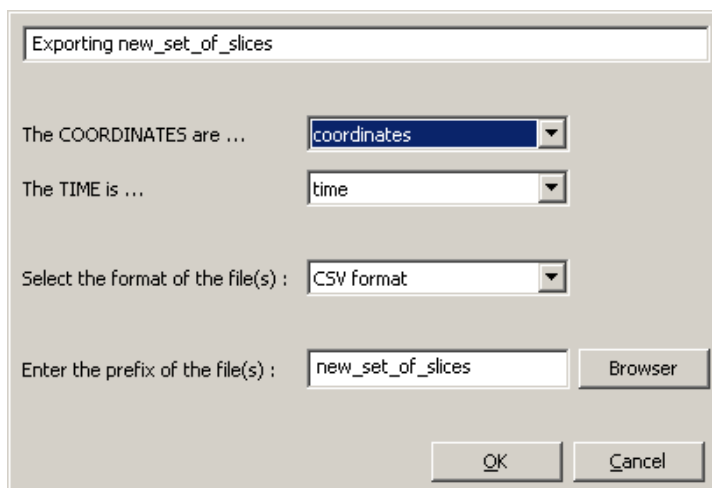



You have now the ability to choose the coordinates and time to be used (useful in some case where absolute and relative coordinates exist, or if you defined your own coordinates or time). The selected property for the COORDINATES will be named "COORDINATES" and will appear as the first property in the file. Useful, if you need to read a CSV file as a generation zone (see § 3.6 for additional information).

You have now the ability to save slices in two different formats:

- a) The default format is "CSV format". One saves the selected set of slices in a set of CSV files. The CSV file format (see Polyflow User's Manual) is a common format for tabulated data that can be read into spreadsheet programs such as Excel. POLYSTAT will generate one file per slice : their names are built like this :

[prefix]_[slice index].csv

- b) The other format is the "FV format". One saves the selected set of slices in a single "FVP" file, that can be loaded in FieldView. This option is useful if your simulation is transient and if you want a better graphic treatment of your trajectories (for steady state simulations, see § 4.1.6). POLYSTAT will generate one file with the name :

[prefix].fvp

After the writing, the set of slices already written appear in the list named "Selected set of slices" of the window "Save Set of Slices". When you have finished, click on the "OK" button in this window to go back to the main window.



4.1.9 THE "WRITE STAT." OPTION

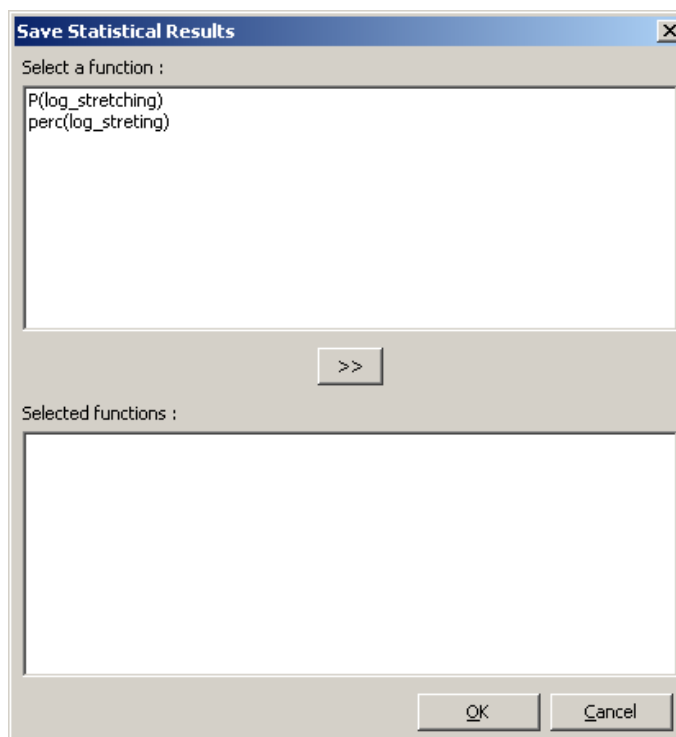

In this window, you will select the functions you want to save in formatted files. First, you select one function in the upper list. Then you click on the ">>" button. A file browser appears; enter now the filename (or the prefix of the filename) to generate. After the writing, the functions already written appear in the lower list. When you have finished, click on the "OK" button in order to go back to the main window.

Depending on the type of function to write, POLYSTAT can generate one or several files : for example, if you select a probability function, there exists a function of the type $y=f(x)$ for each slice, and POLYSTAT will generate a file for each one.

The name of these files are built like this : the user specifies the prefix of the files, and POLYSTAT add an index (if necessary) and a suffix depending on the kind of result you want to save :

see a property along a trajectory :	[prefix]_see[trajectory index].crv
correlation between two fields :	[prefix]_corr.crv
segregation scale :	[prefix]_seg.crv
deviation from an ideal distribution :	[prefix]_dev.crv
sum of a property :	[prefix]_sum.crv
mean of a property :	[prefix]_mean.crv
standard deviation of a property :	[prefix]_stdv.crv



```
deviation of points concentration :      [prefix]_pcd.crv
operator on functions :                 [prefix]_opr.crv

auto-correlation on concentration field : [prefix]_crc[slice index].crv
probability :                           [prefix]_prb[slice index].crv
density of probability :                 [prefix]_dns[slice index].crv
distance distribution :                  [prefix]_dsp[slice index].crv
histograms :                             [prefix]_hst[slice index].crv

percentiles :                             [prefix]_pct[percentile index].crv

distribution in zones :
  global deviation                       [prefix]_zonGI.crv
  deviation for zone i                   [prefix]_zon[zone index].crv
+ zones partitioning,
  points concentration :                 [prefix]_[slice index].csv
                                         (as a set of csv files!)
```

The files are written in the "crv" file format :

I. the optional header is the first 5 lines :

```
line 1 : <empty line>
line 2 : title or name of the current curve
line 3 : <empty line>
line 4 : <empty line>
line 5 : <empty line>
```

II. the next lines are the set of points defining the curve. On each line there is one pair of (x,y) values : the format is 14 characters per value, with 7 digits after the dot. A white space separates the two numbers.

```
next lines :
  ±0.0000000E±00 ±0.0000000E±00
  ±0.0000000E±00 ±0.0000000E±00
  ...
```

4.1.10 THE "SAVE .." OPTION

This option allows you to save in a file (with a "sav" suffix) your current POLYSTAT session. In the session file are saved all information regarding properties (those existing in the mixing files, but also the created ones), set of trajectories, set of slices and of course statistical functions. Let us note that this session file does not contain information regarding mesh and result files (used only for graphical purpose).



4.2 THE PROPERTIES MENU

4.2.1 DEFINITION

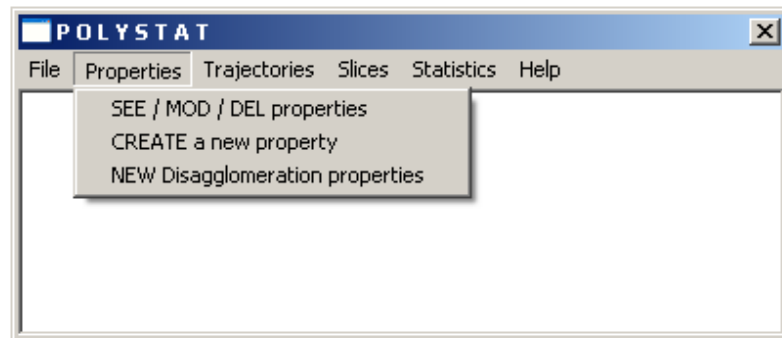

With this menu, you have the ability to define new properties, by combination of the existing ones. Along each trajectory, we have stored a list of values for a small set of parameters (also named properties), like explained in the next drawing :

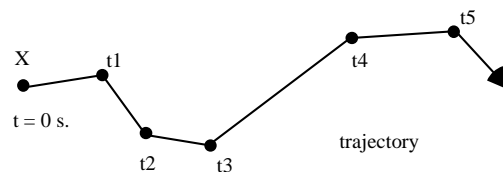

For each particle, for each position stored (at time $t=0$, t_1 , t_2 , ... t_5 , etc.), we can store in the mixing files (from POLYFLOW) several of the following properties :

- 1) the current time, the position (coordinates), the space integration (length of the trajectory from the initial position);
- 2) the *natural* logarithm of stretching ⁽¹⁾ ($\ln \lambda$ or $\ln \eta$), the direction of stretching ($\hat{\mathbf{m}}$ or $\hat{\mathbf{n}}$), the rate of stretching ($\dot{\boldsymbol{\epsilon}} = \dot{\lambda}/\lambda$ or $\dot{\boldsymbol{\epsilon}} = \dot{\eta}/\eta$), the rate of dissipation D ;
- 3) the pressure, the velocity, the temperature;
- 4) the determinant of the tensor \mathbf{F} , the divergence of the velocity. Both parameters give information about the accuracy of the calculation (as the flow is supposed to be incompressible, the determinant of \mathbf{F} must remain equal to one and the divergence of the velocity equal to zero).
- 5) the mixing index, the first eigenvalue of tensor \mathbf{T} , the vorticity.

(1) The words "stretching" and "elongation" are equivalent !



4.2.2 SEE PROPERTIES

After the reading of the mixing files, if you select the option "SEE/MOD/DEL properties" in the "PROPERTIES" menu of the main window, you will see the list of the existing properties :

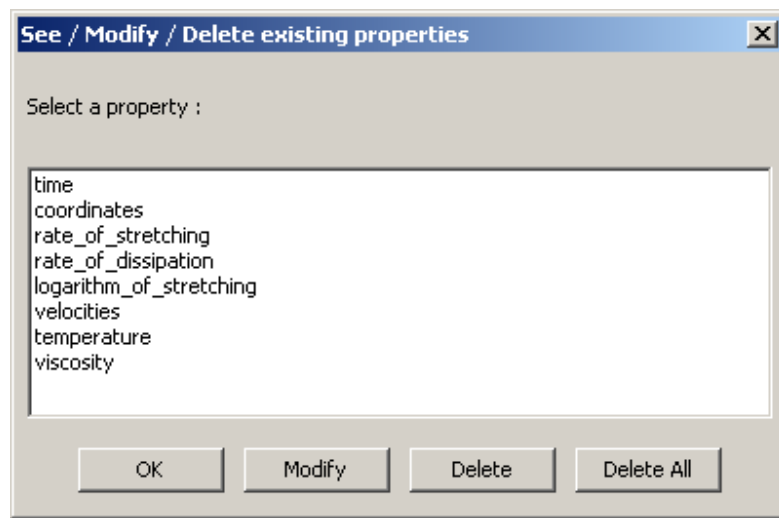

It is possible to modify or to remove from the list one or several properties ⁽¹⁾.

If you want to modify some data of a property, select it in the list, and then click on the "Modify" button. The window that served for the creation of that property will appear; then modify some data. If you want to store the modified data, click on "OK". Otherwise, click on "Cancel".

To remove one property from the list, select it in the list, and then click on the "Delete" button. To remove all the created properties, click directly on the "Delete All" button. In both cases, POLYSTAT asks for a confirmation of your choice.

(1) Only for the properties created in Polystat !



4.2.3 CREATE PROPERTIES

Based on existing properties, it is easy to define new properties. First, select the "CREATE a new property" option in the "PROPERTIES" menu of the main window. The following window appears :

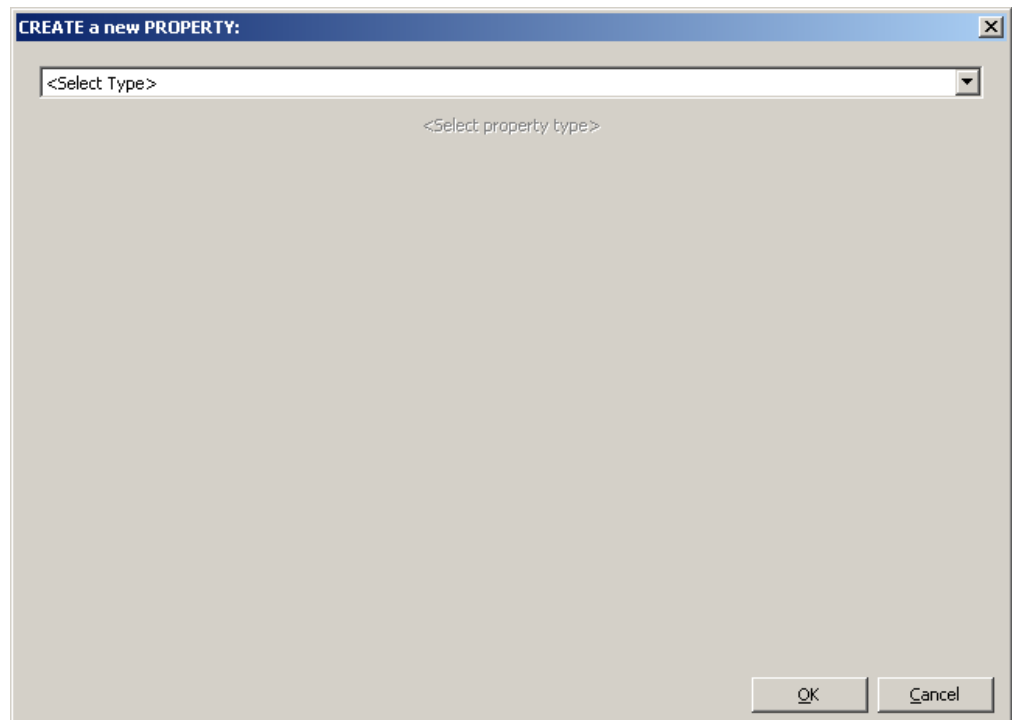

Then click on the button "↓" at the right of the combo box presenting "<Select Type>". A drop down list appears showing the properties that can be created. Eventually, select in this list, the appropriate property.

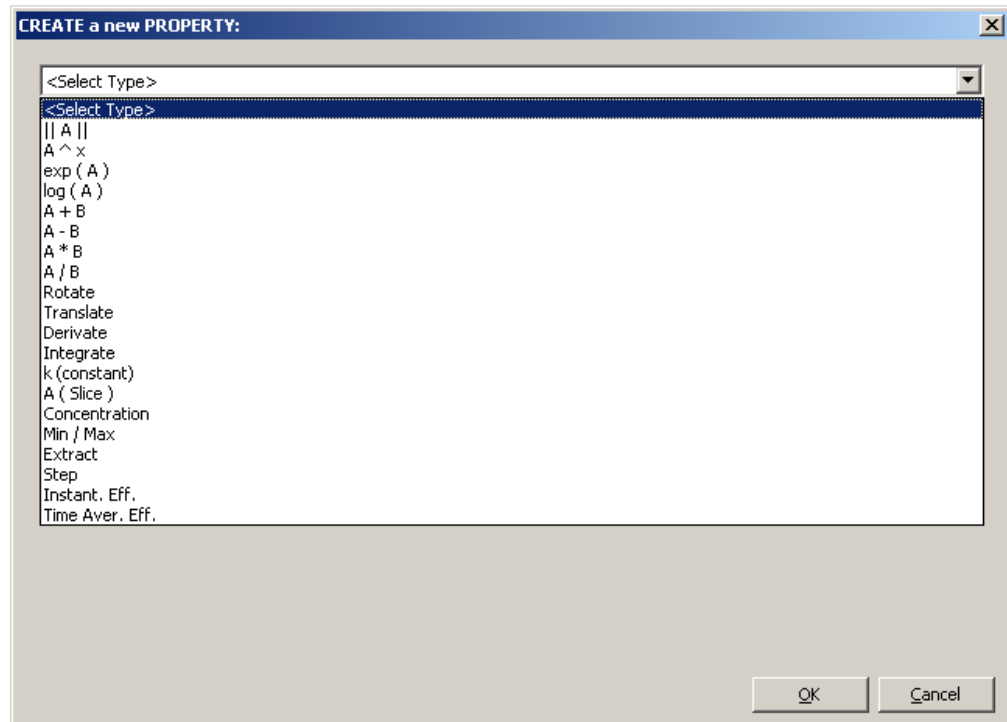

4.2.3.1 |A|

This method allows you to calculate the amplitude of a property (the velocity, for example), or more precisely, the evolution of the amplitude of a property along all the trajectories. After selecting the item |A|, the following window appears :

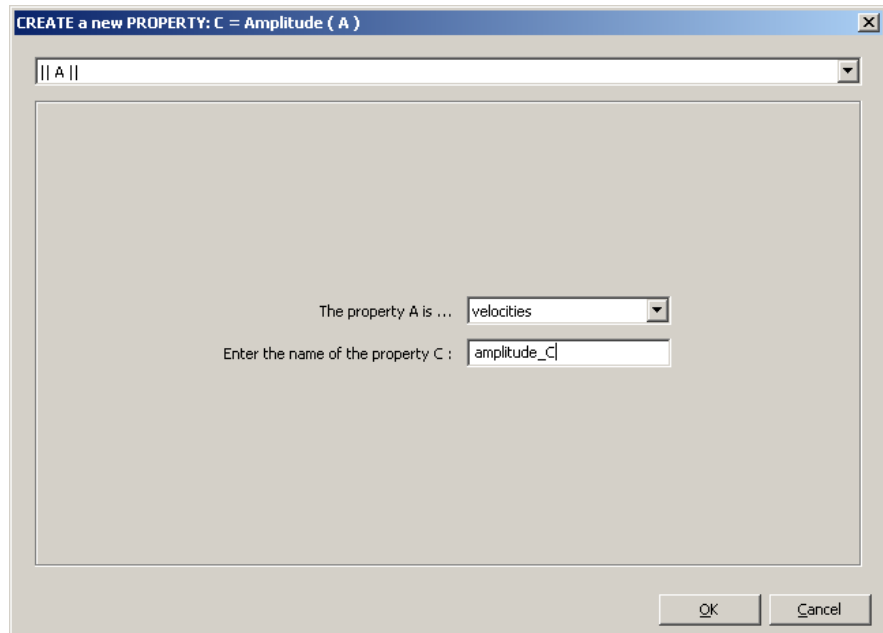

The following data are necessary in this case:

- 1) you select a vectorial or scalar property (the data) ;
- 2) you give a name to the new property (the result). There cannot be two properties with the same name;
- 3) if you agree with the data, click on "OK"; the new property will be stored in the list of existing properties. If you click on "Cancel", there is no storage of this property.



For the other methods, the process is always the same. What changes is the number and the type of the data needed to calculate the new property. Now, let's define each method :

4.2.3.2 A^x

A^x : the new property is the property A exponent x : you have to select the property A (the data), to enter the exponent x , and to give a name to the new property (the result).

4.2.3.3 EXP(A)

exp(A) : the new property is the exponential of the property A : you have to select the property A (the data), and give a name to the new property (the result).

4.2.3.4 LOG(A)

log(A) : the new property is the natural logarithm of the property A : you have to select the property A (the data), and give a name to the new property (the result).

4.2.3.5 $A+B$, $A-B$

$A+B$, $A-B$: the new property is the addition or the subtraction of the properties A and B : you have to select the two properties A and B (the data), and give a name to the new property (the result). The two properties must have the same type (scalar or vectorial).

4.2.3.6 A/B

A/B : the new property is the division of the property A by the property B : you have to select the two properties A and B (the data), and give a name to the new property (the result). The property A can be a scalar or a vector, but the property B must be a scalar.



4.2.3.7 A*B

A*B : the new property is the multiplication of two properties A and B : you have to select the kind of multiplication and the two properties A and B (the data), and give a name to the new property (the result).

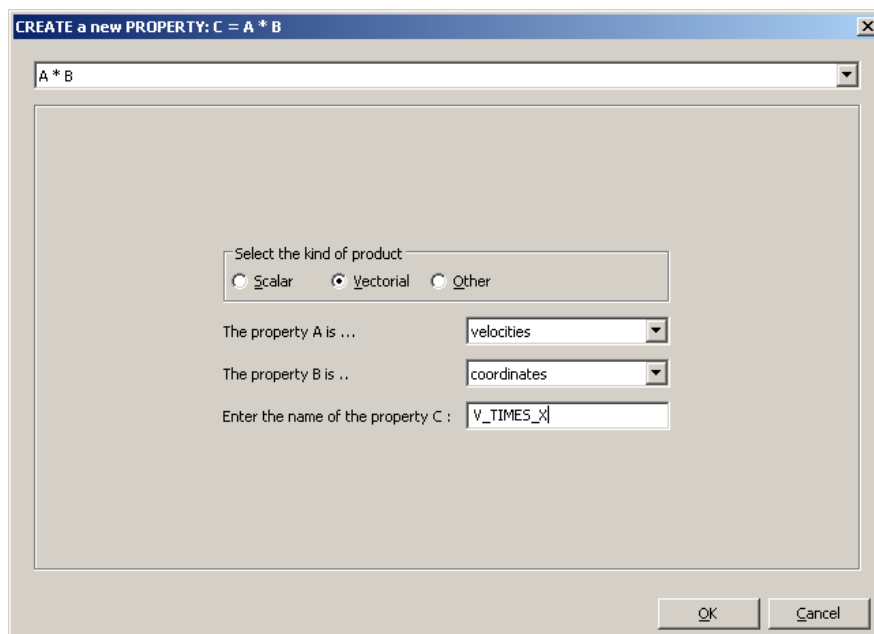

Three cases are possible :

- 1) "Scalar product" (dot product) : both properties A and B are vectors. The result property c is a scalar :

$$c = a_1b_1 + a_2b_2 + a_3b_3 .$$

- 2) "Vectorial product" (cross product) : both properties A and B are vectors. The result property c is a vector :

$$\begin{pmatrix} c_1 \\ c_2 \\ c_3 \end{pmatrix} = \begin{pmatrix} a_2b_3 - a_3b_2 \\ a_3b_1 - a_1b_3 \\ a_1b_2 - a_2b_1 \end{pmatrix} .$$

- 3) "Other product" : you can multiply one scalar by another scalar (the result is a scalar), or one vector by a scalar (the result is a vector).



4.2.3.8 ROTATION

Rotate : this method allows you to rotate a vectorial property : you have to select the property A to rotate and the time (the data), some data specifying the rotation (rotation axis, angular velocity) and to give a name to the new property (the result). This property allows you to change, if necessary, the frame of reference (one in rotation with respect to the other).

The data needed are visualized in the following picture :

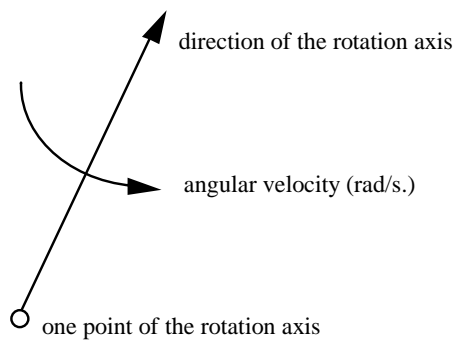

The creation window appears like this :

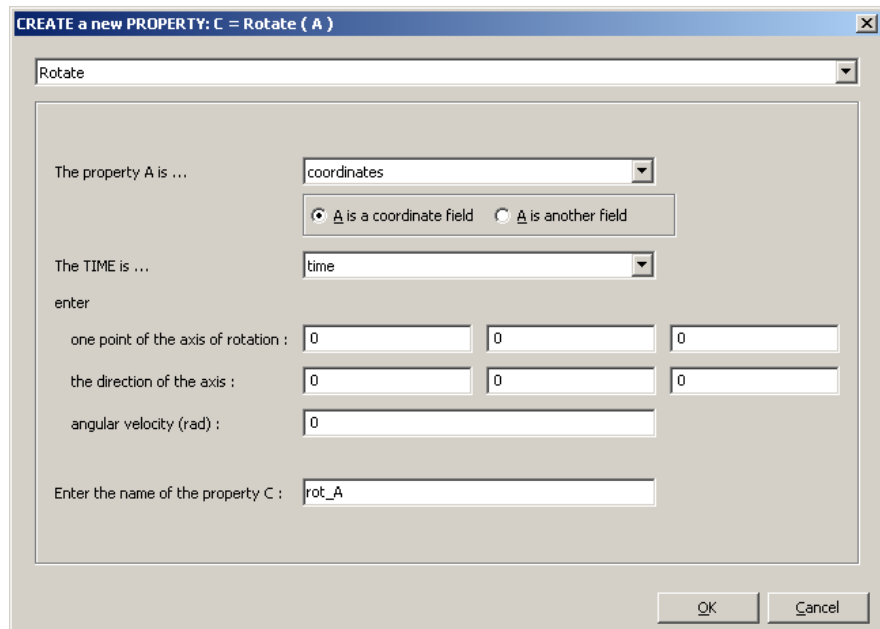



If the property A is a coordinate field, click on the corresponding button. The resulting property C will be :

$$C(t) = X_0 + \underline{\text{Rot}(\alpha, \dots, t)}(A(t) - X_0),$$

where X_0 is one point of the rotation axis, and $\underline{\text{Rot}}$, the matrix of rotation at time t.

However, if the property A is **not** a coordinate field, click on the "A is another field" button. The resulting property C is :

$$C(t) = \underline{\text{Rot}(\alpha, \dots, t)} A(t).$$



4.2.3.9 TRANSLATE

Translate : this method allows you to translate a vectorial property : you have to select the property A to translate and the time (the data), some data specifying the translation (direction and amplitude of the translation velocity) and to give a name to the new property (the result). This property allows you to change, if necessary, the frame of reference (one in translation with respect to the other).

The creation window appears like this :

If the property A is a coordinate field, click on the corresponding button. The resulting property C will be :

$$\mathbf{C}(t) = \mathbf{A}(t) + \mathbf{V}_{\text{trans}} \cdot t,$$

where V_{trans} is the translation velocity and t , the time.

However, if the property A is **not** a coordinate field, click on the "A is another field" button. The resulting property C is :

$$\mathbf{C}(t) = \mathbf{A}(t) + \mathbf{V}_{\text{trans}} .$$



4.2.3.10 INTEGRATE

Integrate : this method allows you to integrate a property along the trajectories (in time) : you have to select the property A to integrate and the time (the data) and to give a name to the new property (the result).

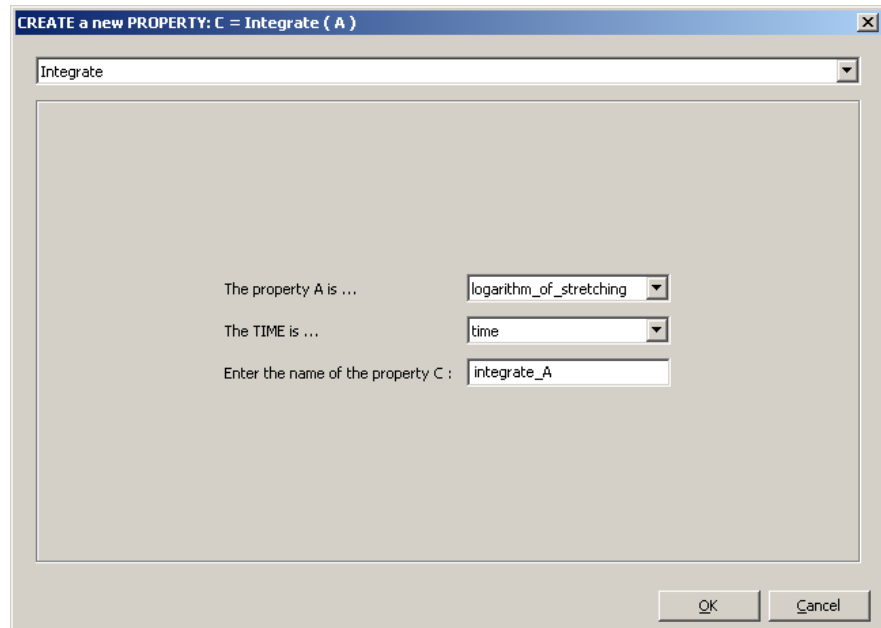



4.2.3.11 DERIVATE

Derivate : this method allows you to derivate a property along the trajectories : you have to select the property A to derivate and the time (the data) and to give a name to the new property (the result).

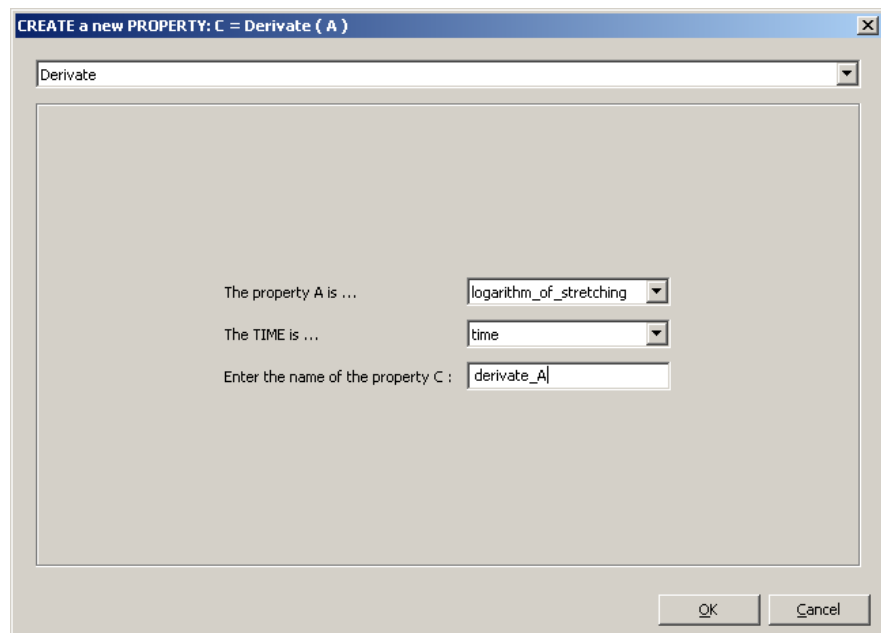



4.2.3.12 K

k : this method allows you to create a property that is constant along all the trajectories : you have to select the type of the constant (scalar, vector with 2 components, vector with 3 components), to specify its value and to give a name to the new property (the result).

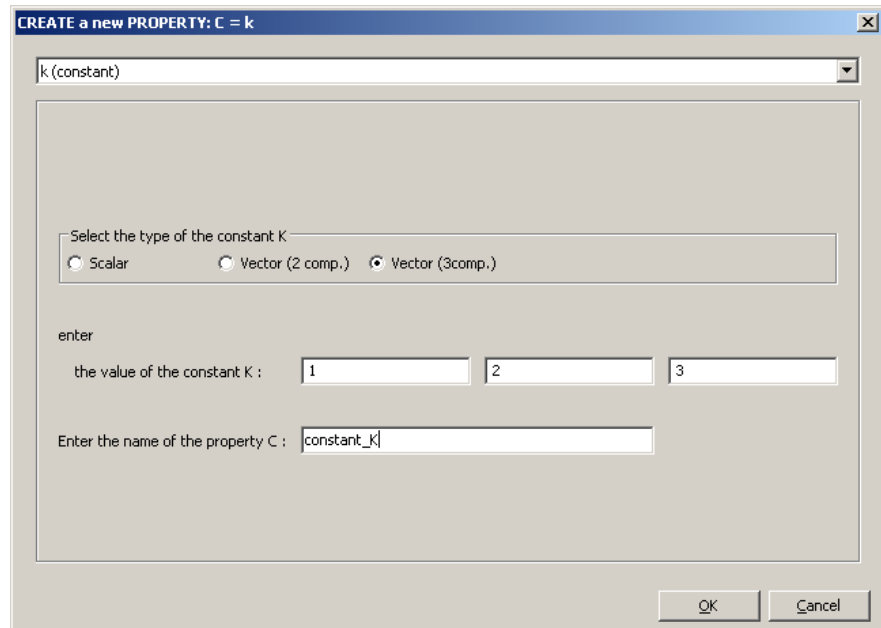



4.2.3.13 A(SLICE)

A(slice) : this method allows you to transport the value of a property along the trajectories : you have to select the property to transport, to define a slice (see § 4.7.1) and to give a name to the new property (the result).

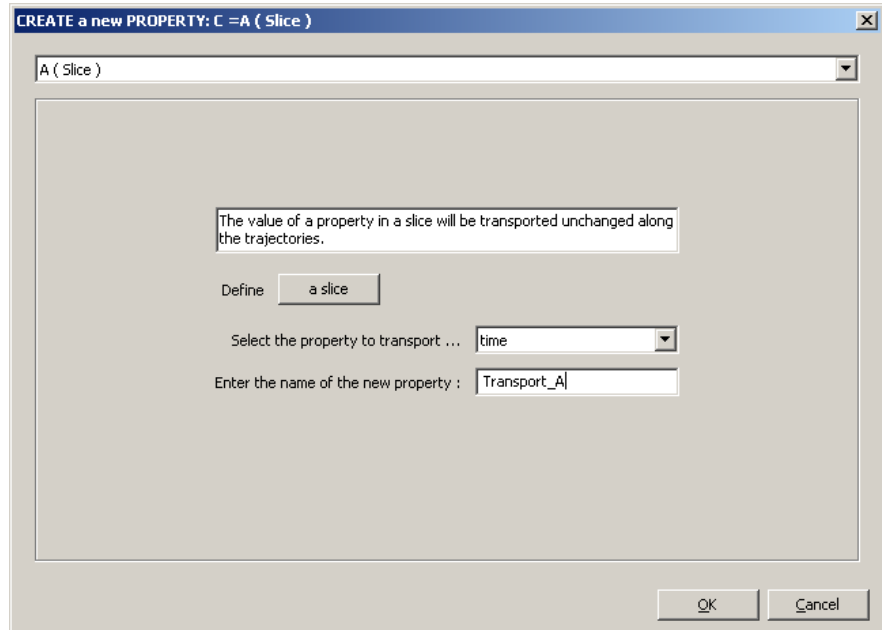

The next picture explains the concept defined above :

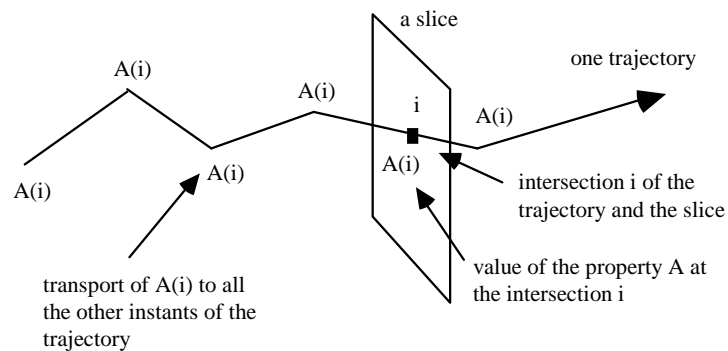

In general, we want to visualize the current value of a property (for example, the temperature) attached to a material point, at the current position of this point. But for the study of mixing, it may be useful to see results differently. For example, if we study the stretching of a set of particles in a Kenics mixer, it may be useful to see at the initial position of the particles their final stretching. By this way, we can detect zones of the inlet from which the stretching is bad or good !



4.2.3.14 CONCENTRATION

Concentration : you can define any concentration field in an initial configuration. As the concentration field is constant for a material point (no diffusion, no chemical reactions), we transport the value of the concentration along the trajectories without making any change : you have to define the initial configuration and give a name to the new property (the result).

The initial configuration is composed of two things; first, you have to specify a slice (see § 4.7.1). Second, you specify a list of zones (see § 4.7.2). In this slice, the instants included in a zone have a concentration value of 1. The instants external to all the zones have a concentration of 0.

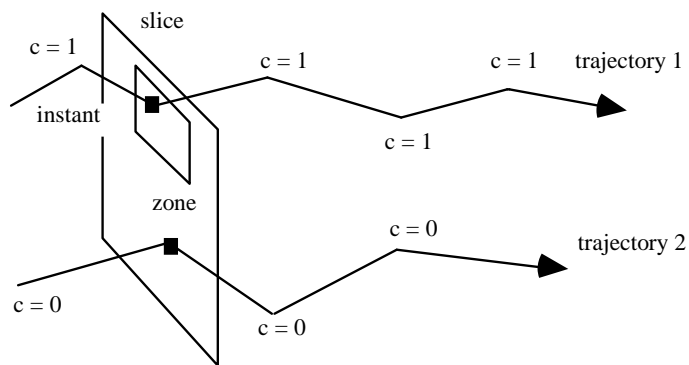

To define such property, the following window appears :

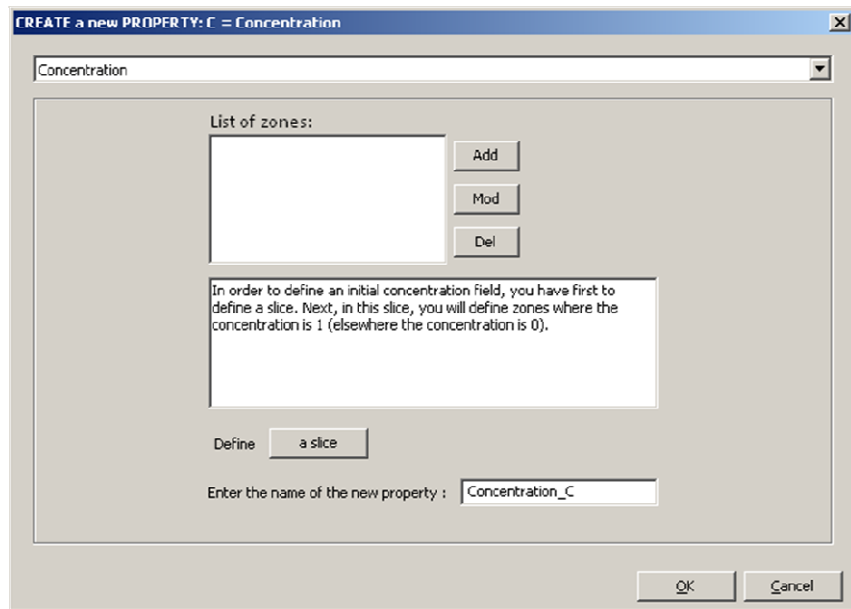



Every zone must have a different name. To define a new zone, click on the "Add" button. If you want to modify an existing zone, select it in the list, and then click on the "Mod" button. If you want to delete an existing zone, select it in the list, and then click on the "Del" button.

4.2.3.15 Min/Max

This method allows you to calculate the minimum (or the maximum) of a property A along trajectories. The following parameters must be defined : a) the property A of interest, b) if we want the minimum or the maximum of the property, c) the name of the resulting property, d) if we want the absolute extreme value of property P along the whole trajectory (option "0 -> t_end") or a time evolving extreme value of property P (option "0 -> t") :

option "0 -> t_end" : for a given trajectory T

$$\min/\max (A) \text{ at any time} = \min/\max \{ A(t_i), \text{ for } t_i = t_o \text{ to } t_{\text{end}} \}$$

option "0 -> t" : for a given trajectory T

$$\min/\max (A) \text{ at time } t = \min/\max \{ A(t_i), \text{ for } t_i = t_o \text{ to } t \}$$

CREATE a new PROPERTY: C = min or max (A)

Min / Max

The property A is ... viscosity

0 -> t_end 0 -> t MAX MIN

Enter the name of the property C : max_A

OK Cancel



4.2.3.16 EXTRACT

This method allows you to create a new scalar property by extracting a component of a vectorial property A. The following parameters must be defined : a) the vectorial property A, b) the component x, y or z to extract (1=x, 2=y, 3=z), c) the name of the resulting property.

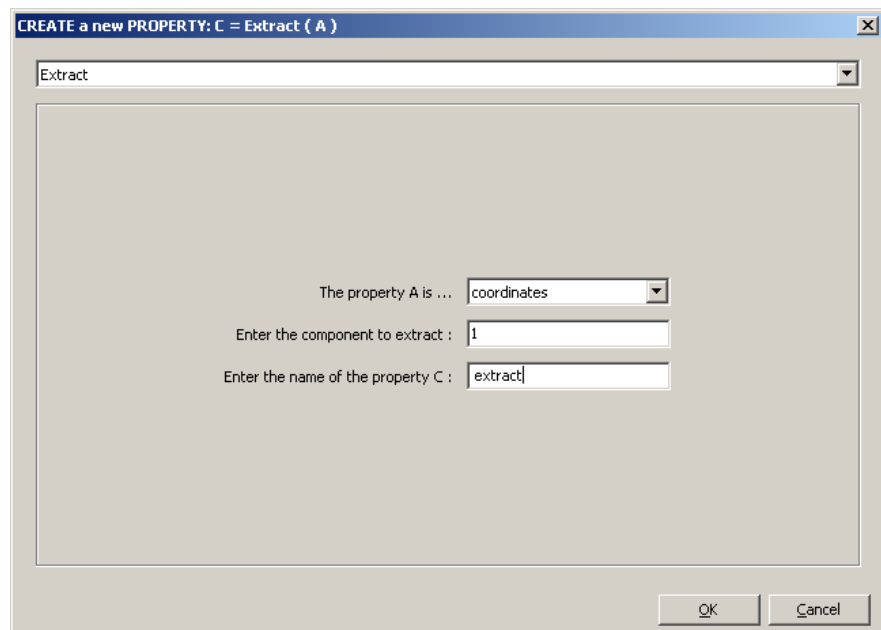



4.2.3.17 STEP

This method allows you to create a new property C defined as follows :

in H mode :

$$\begin{aligned} C(t_i) &= \text{Amplitude,} && \text{if property A at time } t_i \geq \text{threshold value} \\ C(t_i) &= 0, && \text{if property A at time } t_i < \text{threshold value} \end{aligned}$$

in 1-H mode :

$$\begin{aligned} C(t_i) &= 0, && \text{if property A at time } t_i \geq \text{threshold value} \\ C(t_i) &= \text{Amplitude,} && \text{if property A at time } t_i < \text{threshold value} \end{aligned}$$

The following parameters must be defined : a) the property A, b) the "H" or "1-H" mode, c) an amplitude, d) a threshold value , e) the name of the resulting property.

CREATE a new PROPERTY: C = STEP (A)

Step

The property A is ... temperature

H 1-H

Enter the amplitude : 1

Enter the threshold value : 0

Enter the name of the property C : step_A

OK Cancel



4.2.3.18 INSTANTANEOUS EFFICIENCY OF MIXING

This method allows you to create the instantaneous efficiency of mixing based on the rate of dissipation and the rate of stretching. As seen in Chapter 2, this efficiency is defined as :

$$\text{in 2D flows : } e_{\lambda} = \frac{\dot{\lambda}/\lambda}{D} = \frac{\text{rate_of_stretching}}{\text{rate_of_dissipation}}$$

$$\text{in 3D flows : } e_{\lambda} = \frac{\dot{\eta}/\eta}{D} = \frac{\text{rate_of_stretching}}{\text{rate_of_dissipation}}$$

This property is accessible only if the rate of stretching and the rate of dissipation have been calculated along the trajectories. In the creation window, the default values for the properties are correct. This window appears like this

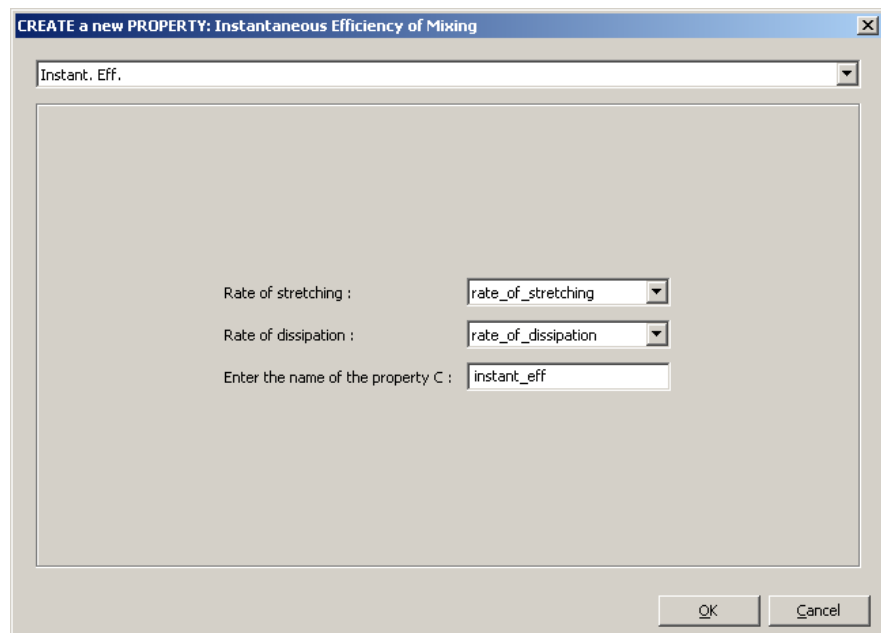



4.2.3.19 TIME AVERAGED EFFICIENCY OF MIXING

This method allows you to create the time averaged efficiency of mixing based on the time, the rate of dissipation and the rate of stretching. As seen in Chapter 2, this efficiency is defined as :

$$\text{in 2D flows : } \langle e_\lambda \rangle = \frac{1}{t} \int_0^t e_\lambda dt$$

$$\text{in 3D flows : } \langle e_\eta \rangle = \frac{1}{t} \int_0^t e_\eta dt$$

This property is accessible only if the time, the rate of stretching and the rate of dissipation have been calculated along the trajectories. In the creation window, the default values for the properties are correct. This window appears like this :

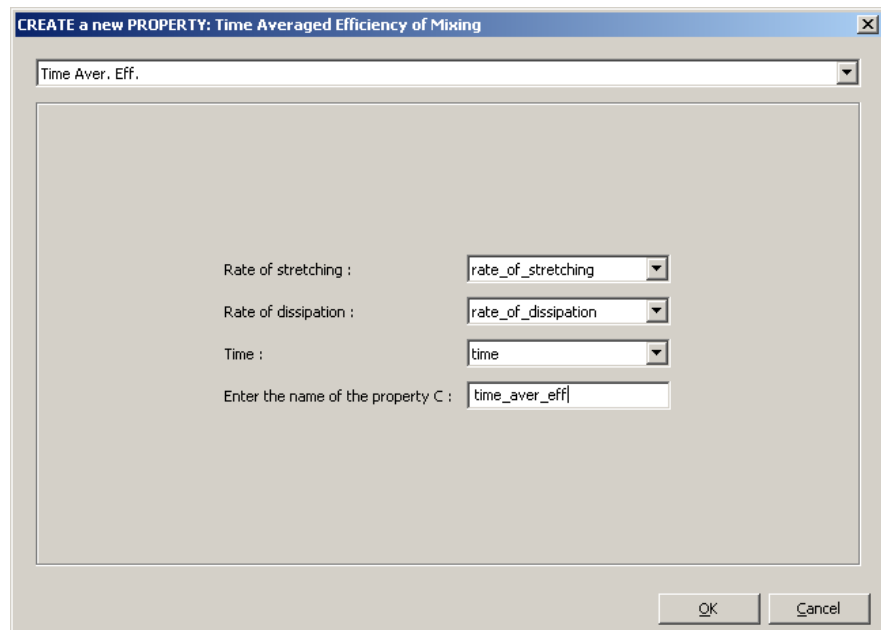



4.2.4 DISAGGLOMERATION PROPERTIES

In this specialized window, it will be possible to create properties directly related to the model of disagglomeration of solid particles, presented in chapter 2.

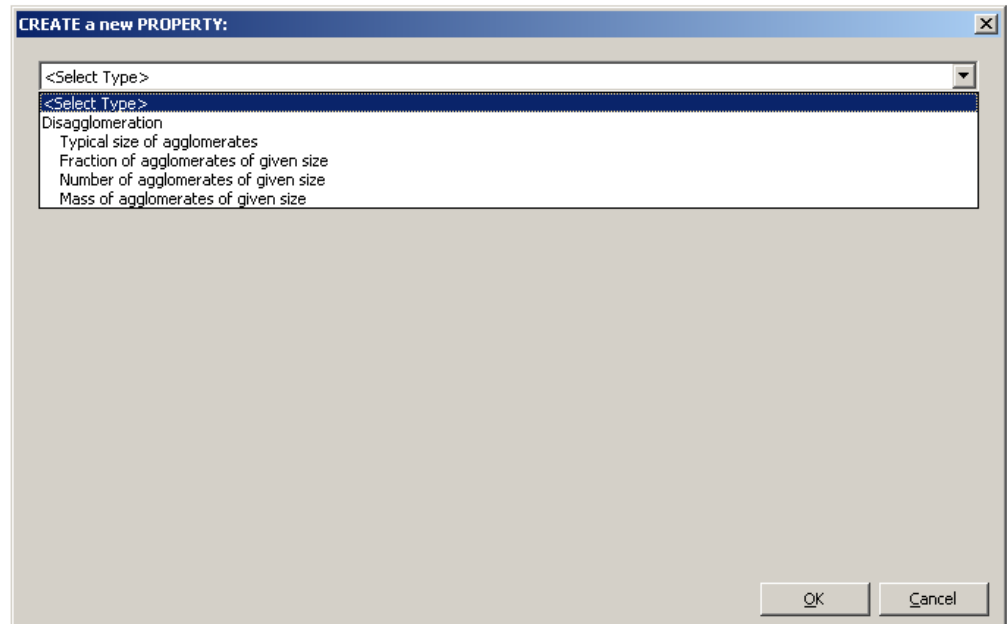

Of course it is not possible to evaluate size, fractions, number of agglomerates without having first define a property of type 'disagglomeration'.



4.2.4.1 DISAGGLOMERATION

CREATE a new PROPERTY: Disagglomeration

Disagglomeration

Select time : time

Select rate_of_dissipation : rate_of_dissipation

Select viscosity : viscosity

Discretization : disagglomeration.clp browser

number of intervals : 50

max. aggregates size : 0

max. agglomerates size : 0

Enter the property name : disagglomeration

Initial size distribution of agglomerates, Erosion and Rupture rate functions are included in file :

OK Cancel

With this property 'Disagglomeration', we will know the time evolution of the mass fraction distribution for a set of agglomerates of various sizes.

As explained in chapter 2, the mechanisms of erosion and rupture depends on time, shear rate and viscosity of the matrix. Those properties must be defined first. Let us note that POLYFLOW solver evaluates the rate of dissipation D instead of the shear rate which is in fact equal to $\sqrt{2D}$.

Next the user must specify the number of classes of agglomerates he wants to evaluate. He must specify the size of the largest agglomerates and the maximum size of the aggregates (particles that cannot be broken in smallest pieces anymore).

Next, the user must specify in which 'CLIPS' file are defined transfer function for erosion and rupture mechanisms, the kinetics of erosion and rupture (function of shear rate, viscosity, size of agglomerates), and of course the initial distribution function of agglomerates size. As this file is interpreted during the calculation, it is very easy to modify those functions, as the understanding of the disagglomeration improves, or to test new ideas.



4.2.4.2 TYPICAL SIZE OF AGGLOMERATES

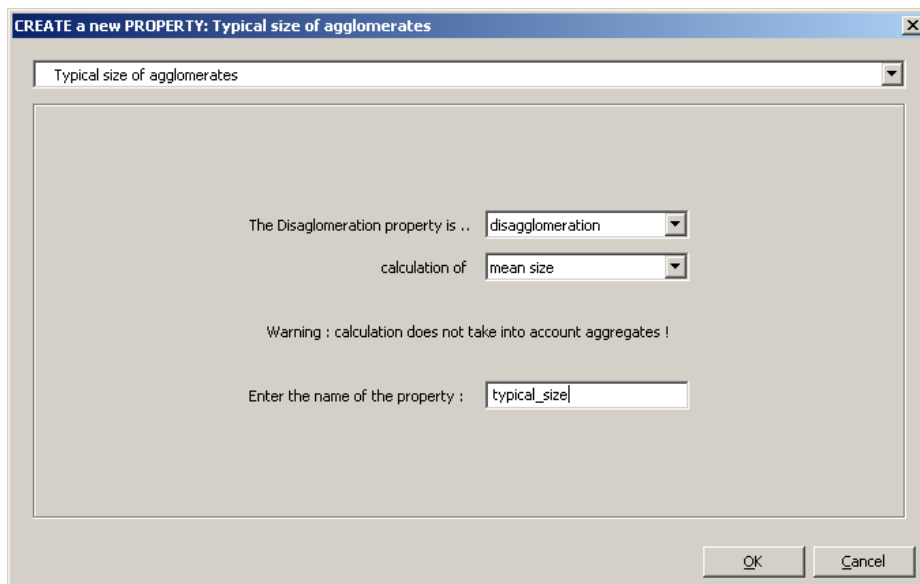

With this function it is possible to evaluate the minimum, mean or maximum size of agglomerates, **without taking into account the aggregates**. To do that, we evaluate a new distribution function ranged between the maximum size of aggregates (a) and the maximum size of agglomerates (b) :

$$\tilde{f}(s, t) = f(s, t) \Big/ \int_a^b f(s, t) ds, \text{ in range } [a, b], \text{ and } \tilde{f}(s, t) = 0, \text{ otherwise.}$$

The mean size of agglomerates is thus :

$$\text{Mean size (t)} = \int_a^b \tilde{f}(s, t) s ds \Big/ \int_a^b \tilde{f}(s, t) ds, \text{ where } \int_a^b \tilde{f}(s, t) ds = 1.$$

The minimum and maximum sizes are evaluated as shown in the picture below. They corresponds -in fact- to the 5-th percentile and 95-th percentile of the \tilde{f} function :

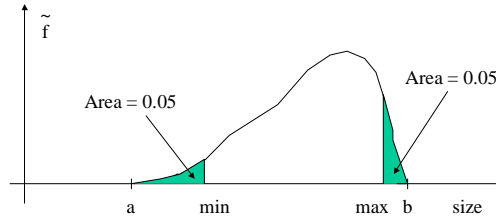

4.2.4.3 FRACTION OF AGGLOMERATES OF GIVEN SIZE

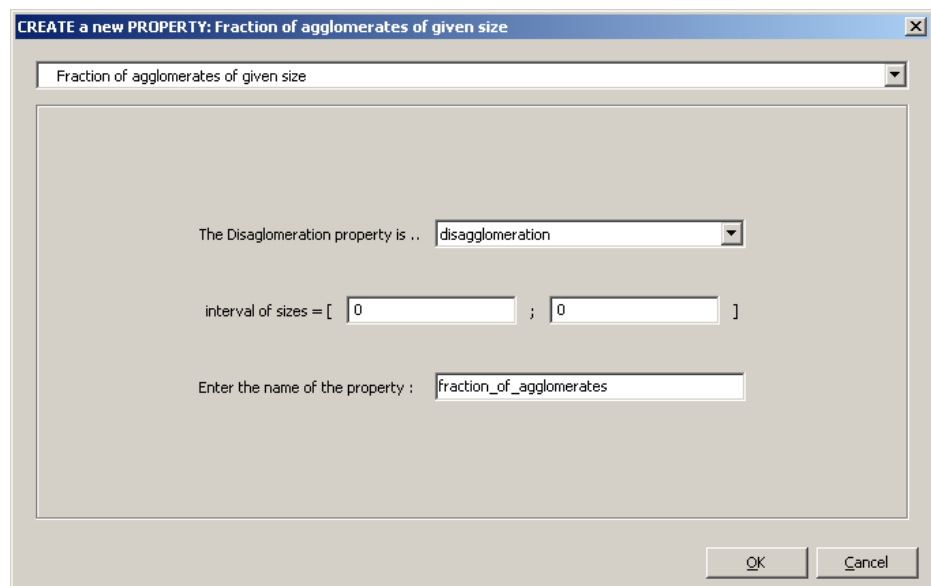

With this property, the user can evaluate the mass fraction of agglomerates, at a given time, having a size between a given range [Sa; Sb] :

$$Frac_{[Sa;Sb]}(t) = \int_{Sa}^{Sb} f(s,t) ds$$



4.2.4.4 NUMBER OF AGGLOMERATES OF GIVEN SIZE

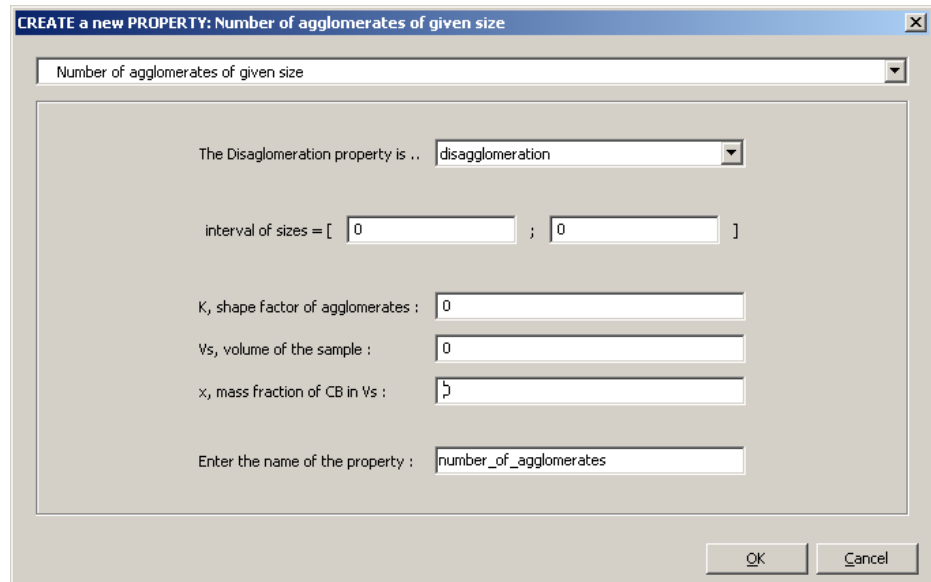

With this property, the user can evaluate the number of agglomerates, at a given time, having a size between a given range [Sa; Sb] :

$$N_{[Sa;Sb]}(t) = \frac{Vs \chi Frac}{k S_{mean}^3}$$

where $Frac_{[Sa;Sb]}(t) = \int_{Sa}^{Sb} f(s,t) ds,$

$$S_{mean} (t) = \frac{\int_{Sa}^{Sb} f(s,t) s ds}{\int_{Sa}^{Sb} f(s,t) ds},$$

Vs is the volume of a sample able to contain a large number of agglomerates of various sizes,

χ is the mass fraction of agglomerates included in the sample Vs,

and k is a shape factor ($k = \pi/6$ if we assume that agglomerates are spheres, $k=1$, if they are cubes !)



4.2.4.5 MASS OF AGGLOMERATES OF GIVEN SIZE

CREATE a new PROPERTY: Mass of agglomerates of given size

Mass of agglomerates of given size

The Disagglomeration property is ..

interval of sizes = [;]

Ro, volumic mass of pure CB :

Vs, volume of the sample :

x, mass fraction of CB in Vs :

Enter the name of the property :

OK Cancel

With this property, the user can evaluate the mass of agglomerates, at a given time, having a size between a given range [Sa, Sb] :

$$m_{[Sa;Sb]}(t) = Vs \chi \rho_{CB} Frac$$

$$\text{where } Frac_{[Sa;Sb]}(t) = \int_{Sa}^{Sb} f(s,t) ds,$$

Vs is the volume of a sample able to contain a large number of agglomerates of various sizes,

χ is the mass fraction of agglomerates included in the sample Vs,

and ρ_{CB} is the density (mass per unit volume) of pure agglomerates.



4.3 THE TRAJECTORIES MENU

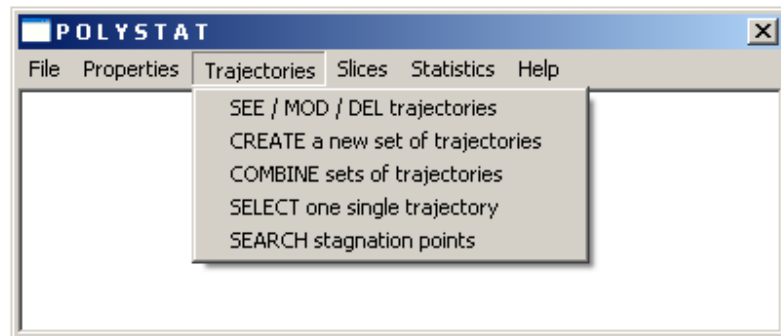

The "See/Mod/Del sets of trajectories" option allows the user to manage the list of existing sets of trajectories. With the CREATE option, the user will define a new set as a subset of an existing one, based on a selection criterion. With the COMBINE option, the user will define a new set by selecting trajectories with boolean operations between two existing sets. Eventually, with the SELECT" option, the user can select a single trajectory from an existing set based on a selection criterion.

4.3.1 SEE SET OF TRAJECTORIES

After the creation of new properties, you have the ability to select the set of trajectories on which you will do some statistical treatment. Before any creation of such sets, if you select the option "SEE/MOD/DEL sets of trajectories" in the "TRAJECTORIES" menu of the main window, you will see the list of the existing sets of trajectories :

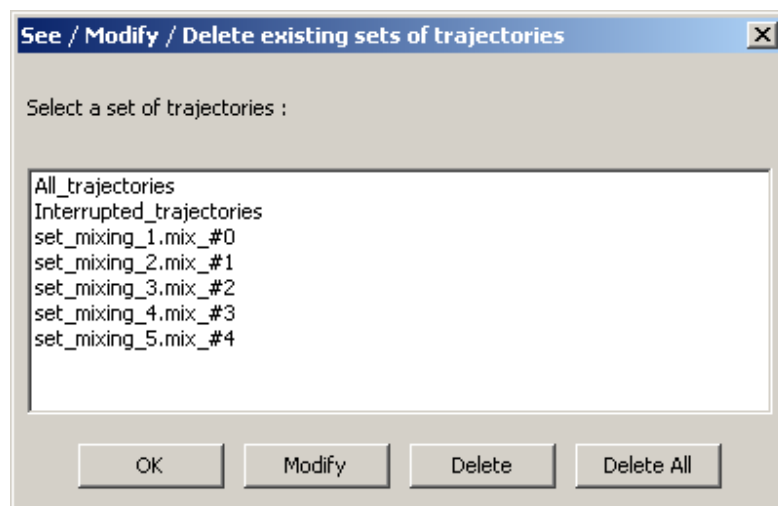



In this list, you can see three different types of sets of trajectories :

- a) the "All trajectories" set contains all the trajectories read in the mixing files.
- b) the "Interrupted trajectories" set contains all the trajectories the calculations of which have been interrupted (for different possible numerical problems) and read in the mixing files.
- c) the "set_from_filename" sets contain the trajectories stored in the mixing file "*filename*".

We cannot modify or delete those sets. If we remove a mixing file (in the window "READ data"), the list of existing sets is adjusted automatically.

If new sets of trajectories have been created, it is possible to modify or to remove them from the list.

If you want to modify some data of a set, select it in the list, and then click on the "Modify" button. The window that served for the creation of that set will appear; then modify some data. If you want to store the modified data, click on "OK". Otherwise, click on "Cancel".

To remove one set from the list, select it in the list, and then click on the "Delete" button. To remove all the created sets, click directly on the "Delete All" button. In the two cases, POLYSTAT asks for a confirmation of your choice.

Based on existing sets of trajectories, it is easy to define new sets. Four possibilities exist; a) the creation of a new set based on a condition to respect, b) the combination of two sets to create a new one, c) the selection of a single trajectory, based on a criterion of proximity, d) the selection of trajectories of stagnant points.



4.3.2 THE "CREATE A NEW SET OF TRAJECTORIES" OPTION

By clicking on this option in the main window, the following window appears :

Add a new set of trajectories

Select a set of trajectories : All_trajectories

Select a property : time

Enter

the minimum value : 1 2 3

the maximum value : 4 5 6

To construct this new set, we will keep the trajectories that have always

the values of the selected property between the minimum and the maximum.

Enter the name of the new set : new_set

OK Cancel

With this method, we will select a subset of trajectories that respect a condition. Three kinds of condition are possible :

- a trajectory is selected if, along this one, the property has **always** values in the specified interval. For example, we can select the trajectories that have always the determinant of F between .99 and 1.01 (we reject inaccurate trajectories).
- a trajectory is selected if, along this one, the property has **never** values in the specified interval.
- a trajectory is selected if, along this one, the property has **one time at least** a value in the specified interval. For example, we can select the trajectories that cross a specified box in the flow domain.

If the selected property is a scalar, the interval is defined in the rectangles 1 and 4 (the others are set to zero).



4.3.3 THE "COMBINE SETS OF TRAJECTORIES" OPTION

If we select this option, the following window appears:

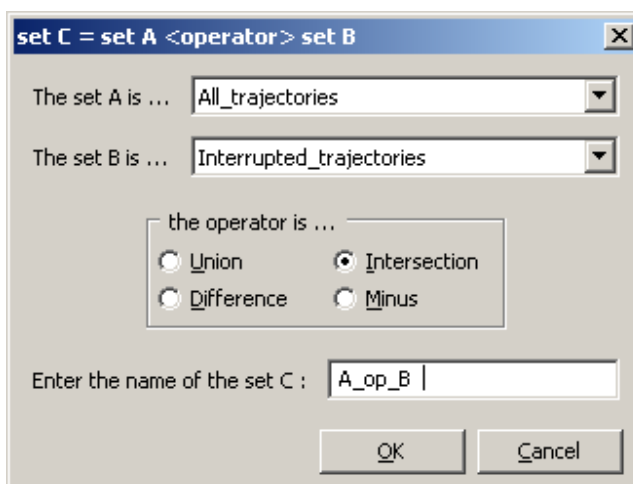

With this option, we can combine logically two sets of trajectories A and B in order to create a new set C.

For example, in the window above, we selected the sets "All_trajectories" and "Interrupted_trajectories" and the "Intersection" operator. That means that the new set C will contain the trajectories that belong to the two sets A and B.

If we select the "Union" operator, the new set C will contain all the trajectories of the two sets A and B (there is no duplication of the trajectories that belong to the two sets).

If we select the "Minus" operator, the new set C will contain the trajectories of the set A that do not belong to the set B.

If we select the "Difference" operator, the new set C will contain the trajectories of the set A that do not belong to the set B and the trajectories of the set B that do not belong to the set A. We can write this operation as : $C = (A \text{ Minus } B) \text{ Union } (B \text{ Minus } A)$.



4.3.4 THE "SELECT ONE SINGLE TRAJECTORY" OPTION

By selecting this option, the following window appears :

Select a single trajectory

Select a set of trajectories : All_trajectories

Select a coordinates field : coordinates

Define a position : 1 2 3

We will select the trajectory which is the closest to this position

Initially Independantly of the moment

Enter the name of this trajectory : single_trajectory

OK Cancel

With this method, we will select a single trajectory from a set that is the closest to a specified position.

We have to specify the following data :

- a) a set of trajectories in which we will search **one** trajectory;
- b) a property;
- c) a position;
- d) an option for the selection : if we choose "Initially", we select the trajectory whom its initial position is the closest to the specified position. If we choose "Independantly ...", we don't specify any peculiar moment.

The selected property is not necessarily a coordinate property. We can, for example, select the trajectory that has an initial velocity the closest to the value (1,2,3) !

If the selected property is a scalar, enter the "position" in the rectangle 1 (the rectangles 2 and 3 are set to zero).



4.3.5 THE "SEARCH STAGNATION POINTS" OPTION

By selecting this option, the following window appears :

Search stagnation points

Select a set of trajectories : All_trajectories

Select a coordinates field : coordinates

Select a time field : time

Enter the threshold distance : 0

Enter period : 0

Enter stagnation time : 0

Enter squeezing factor : 1 1 1

Enter the name of the set : stagnation_points

OK Cancel

With this method, we will select points having a specific behavior : the points remaining close to their initial position, or those coming back -after a specific period- close to their initial position.

We have to specify the following data :

- a set of trajectories in which we will search **stagnation points**;
- a coordinate field;
- a time field;
- a threshold distance : a point is stagnant if the distance between its initial position X_0 and some of its successive positions X_t are less than this threshold distance.
- a period 'P':
 - if one wants to detect **stagnation** points close to a fixed wall, we impose the period P to zero: all successive positions X_t will be tested from $t=0$ until $t=\text{stagnation time } t_s$.
 - if one wants to detect **stagnation** points close to a rotating wall (of a moving part, e.g.), we have to specify the period P of rotation of the moving part : all positions $X_t = X_0 + nP$ will be tested from $t=0$ until $t=\text{stagnation time } t_s$.
- a stagnation time 'ts' :
 - this stagnation time 'ts' must be in the range $[0, \text{max. residence time}]$.



g) squeezing factor (sx,sy,sz) :

it is a way to weight specifically some components of the coordinates when computing distance between X_0 and X_t :

$$\text{distance}(X_0, X_t) = \sqrt{sx(x_0-x_t)^2 + sy(y_0-y_t)^2 + sz(z_0-z_t)^2}$$

By default, the squeezing factor is set to (1, 1, 1).



4.4 THE SLICES MENU

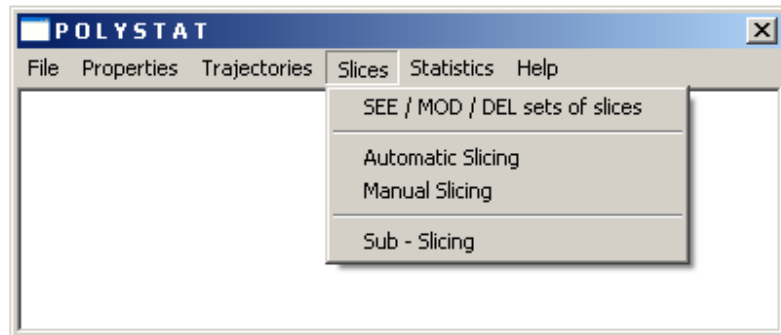

After the creation of new sets of trajectories, you must select one set on which you will perform some statistical treatment. Before this step, you have first to define a list of slices that cut the trajectories. This list is necessary to analyze the evolution of the mixing from one slice to the next, from the beginning of the process to its end. By default, no set of slices exists !

Based on an existing set of trajectories, it is easy to define a set of slices. Three possibilities exist; a) the automatic creation of a list of slices, b) the manual definition of each slice, one by one, c) the sub-slicing which is the generation of a new list of slices based on each slice of an other list.

Remember that a trajectory is a set of instants ordered in time. Each slice will contain a set of instants that are the intersections of the slice and the trajectories. If the intersection of a trajectory and a slice is not a stored instant, we create a new instant by interpolation with the previous and the next instants that surround the intersection, as explained below :

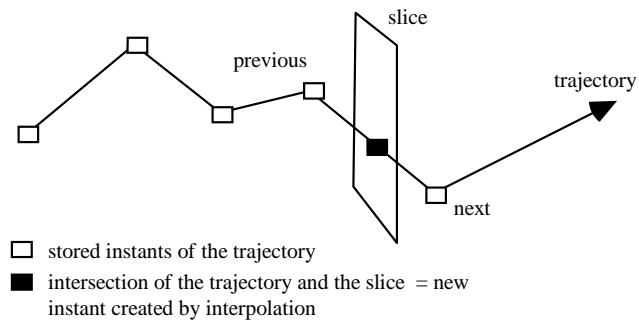



4.4.1 SEE SET OF SLICES

If you select the option "SEE/MOD/DEL sets of slices" in the "SLICES" menu of the main window, you will see the list of the existing sets of slices :

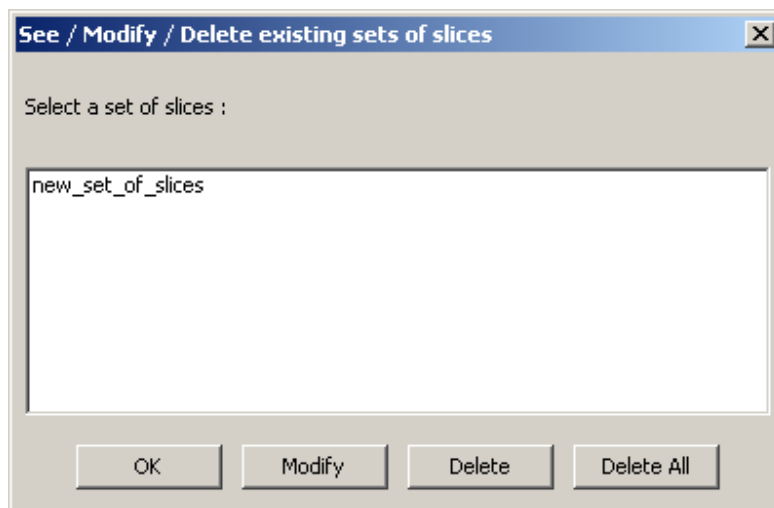

If you want to modify some data of a set, select it in the list, and then click on the "Modify" button. The window that served for the creation of that set will appear; then modify some data. If you want to store the modified data, click on "OK". Otherwise, click on "Cancel".

To remove one set from the list, select it in the list, and then click on the "Delete" button. To remove all the created sets, click directly on the "Delete All" button. In the two cases, POLYSTAT asks for a confirmation of your choice.



4.4.2 THE "AUTOMATIC SLICING" OPTION

Create 'Automatically' a list of slices

Select a set of trajectories : All_trajectories

Select a property : time

Enter the name of the set of slices : new_set_of_slices

Enter

the first position : 1 2 3

the direction : 4 5 6

the increment : 7

the number of slices : 8

OK Cancel

With this method, you generate automatically a list of ordered slices. You have first to select a set of trajectories on which the slicing will be done. Second, you specify the first slice of the list; you select a property, a position and a direction for the plane. Third, you enter the number of slices you want and the distance (increment) between two successive planes. Finally, you enter the name of the new set.

This slicing is based on a single property and all the slices are parallel to each other. This is not the case for the manual method.



4.4.3 THE "MANUAL SLICING" OPTION

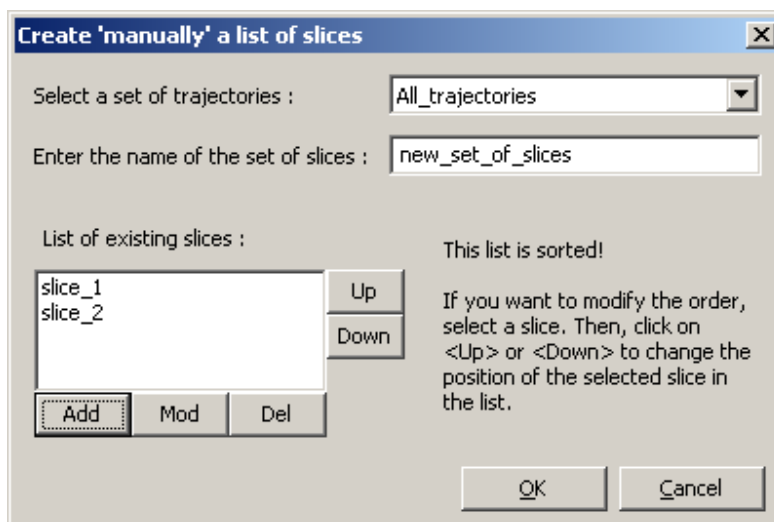

With this method, you generate manually, one by one, a list of ordered slices. You have first to select a set of trajectories on which the slicing will be done. Second, you specify each slice one by one. Each slice must have a different name. You can modify or delete existing slices. You can also modify the order of the slices; it is important to notice, because the statistical functions are also ordered in function of the slices on which they are based. Finally, you enter the name of the new set.

This slicing is not based on a single property; each slice can be defined on a different property. The slices are not necessarily parallel to each other. This method is more general, but is more time consuming for the user !



4.4.4 THE "SUB-SLICING" OPTION

Generate a subslicing on a set of slices

Select a set of slices : new_set_of_slices

Select a property : time

Periodic?
 Yes No

Enter

the first position : 1 2 3

the direction : 4 5 6

the increment : 7

the number of subslices (/slice) : 8

Enter the name of the set of slices : new_set_of_subslashes

OK Cancel

Suppose that you have a 3D unsteady flow, and that you want to visualize the spatial repartition of the stretching in a plane cutting your flow domain ! Suppose that you define a slice whom the selected property is the coordinates, the instants in this slice can have various time. What you want to do is to distribute those instants among a list of time intervals, and look at the spatial repartition of the stretching for one time interval. What you have done above is called "sub-slicing" : you defined a list of slices on another list of slices.

To define a sub-slicing, you select first an existing set of slices. Next, you define your slicing data (as for an automatic slicing). What differs is the number of sub-slices (for each slice) and if the sub-slicing is periodic or not.

Let's define N , the number of sub-slices by slice. After sub-slicing, the sub-slice indices will be :

for the slice 1, the sub-slices are numbered from 1 to N ;

for the slice 2, the sub-slices are numbered from $N+1$ to $2N$;

for the slice 3, the sub-slices are numbered from $2N+1$ to $3N$;

etc...



If we select the "Periodic" option, we gather the instants in the following way : for a given slice, the instants included in the series of intervals named "i" are gathered in the sub-slice "i".

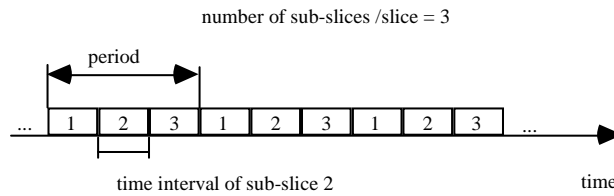

If we do not select the "Periodic" option, we gather the instants in the following way : for a given slice, the instants included in the interval named "i" are gathered in the sub-slice "i".

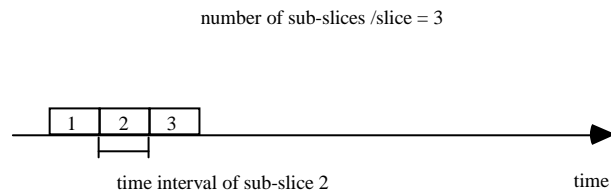



4.5 THE STATISTICS MENU

After the creation of properties, set of trajectories and sets of slices, you have to define the statistical functions you want to calculate on these objects. By default, no function exists ! General ones can be created by selecting "CREATE a new function", while functions specific to the disagglomeration model can be found in "NEW disagglomeration functions".

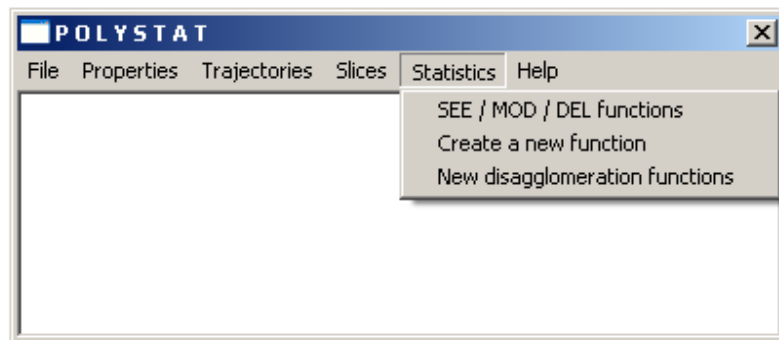

4.5.1 SEE STATISTICAL FUNCTIONS

If you select the option "SEE/MOD/DEL functions" in the "STATISTICS" menu of the main window, you will see the list of the existing functions :

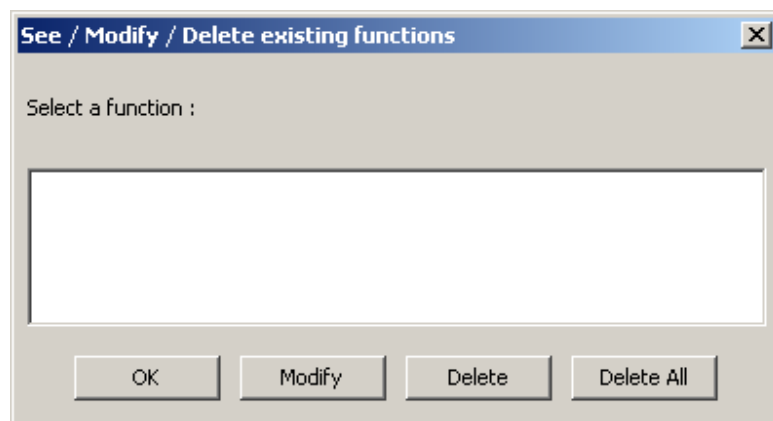

If you want to modify some data of a function, select it in the list, and then click on the "Modify" button. The window that served for the creation of that function will appear; then modify some data. If you want to store the modified data, click on "OK". Otherwise, click on "Cancel".

To remove one function from the list, select it in the list, and then click on the "Delete" button. To remove all the created functions, click directly on the "Delete All" button. In both cases, POLYSTAT asks for a confirmation of your choice.



4.5.2 CREATE STATISTICAL FUNCTIONS

If you select the option "CREATE a new function" in the "STATISTICS" menu of the main window, the following window appears :

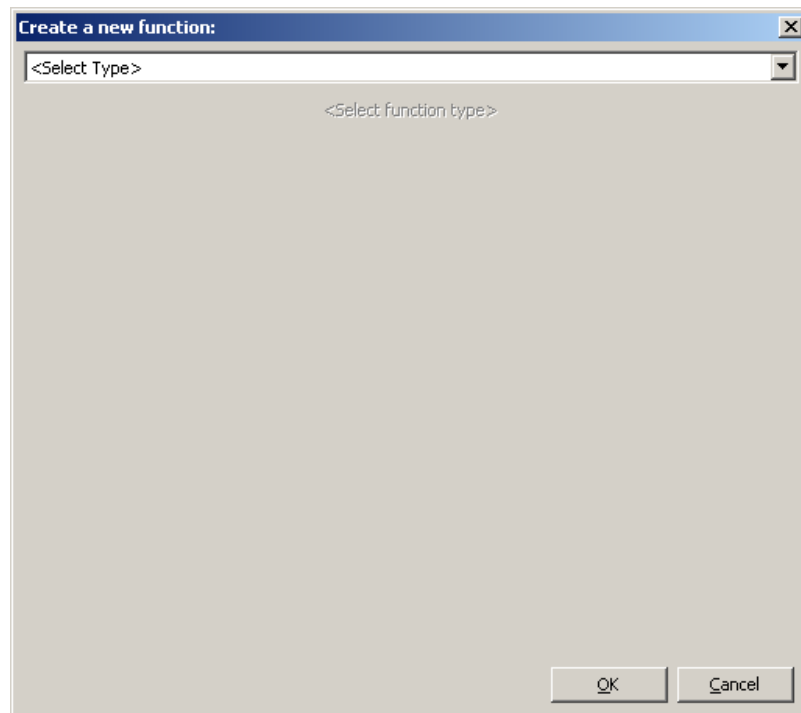

Then click on the button "↓" at the right of the combo box presenting "<Select Type>". A drop down list appears showing the functions that can be created. Eventually, select in this list, the appropriate statistical function.

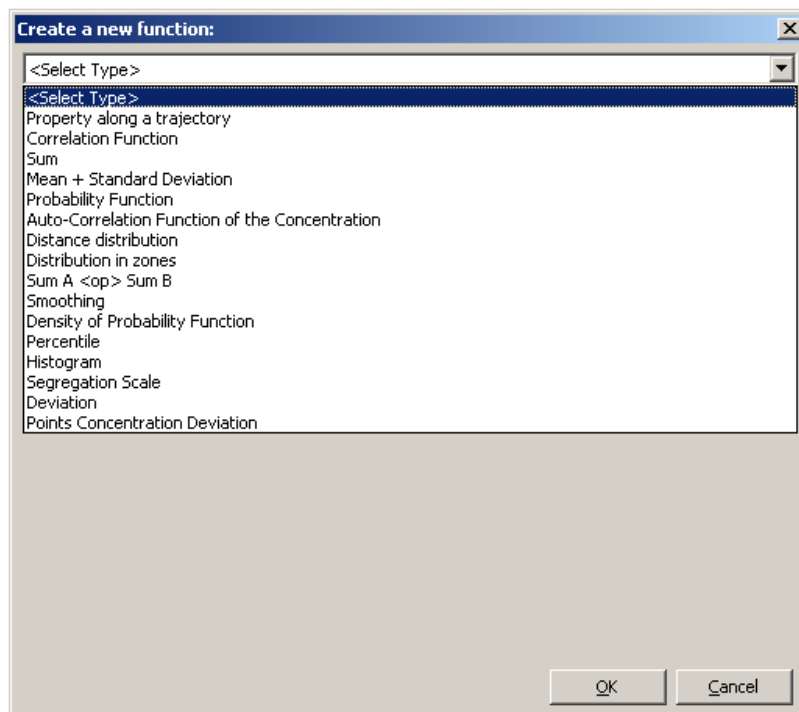

If you want to go back to the main window, click on the "Cancel" button.

There exist three kinds of functions; the first one are functions based directly on the instants of slices. The second one are functions based on other functions. Eventually, the last one are functions based on a set of trajectories.

To create a new function, click on the corresponding item in the list. Let's have a look now to every function in detail.



4.5.2.0 THE "SEE PROPERTY ALONG A TRAJECTORY" FUNCTION

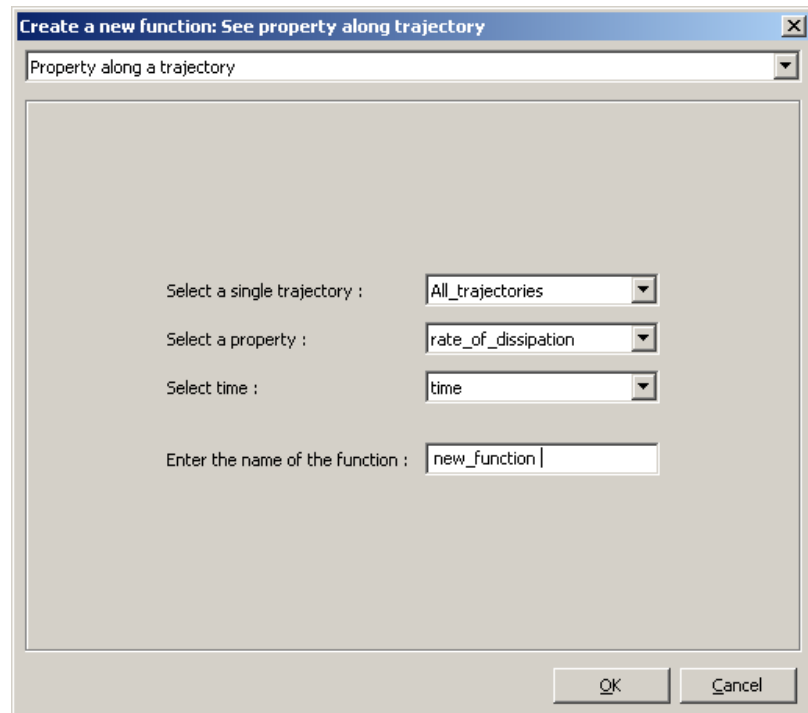

With this function, the user will see the time evolution of a given property calculated along any trajectory he wants.

The user has to specify which set of trajectories will be used, to select the property to see, and the time. One has also to give a name to the new function.

If you visualize this function, you find on the X axis the time and on the Y axis, the property of interest. In this graph, you have a new function $y=f(x)$ for each trajectory :

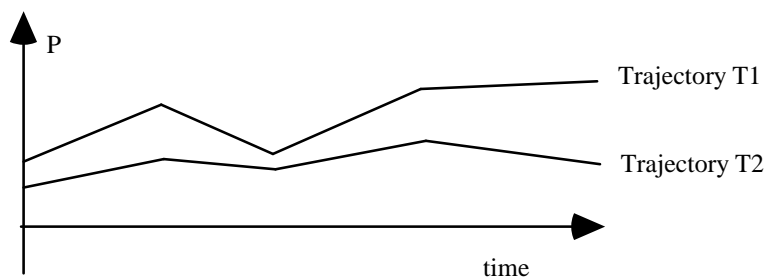



4.5.2.1 THE "SUM" FUNCTION

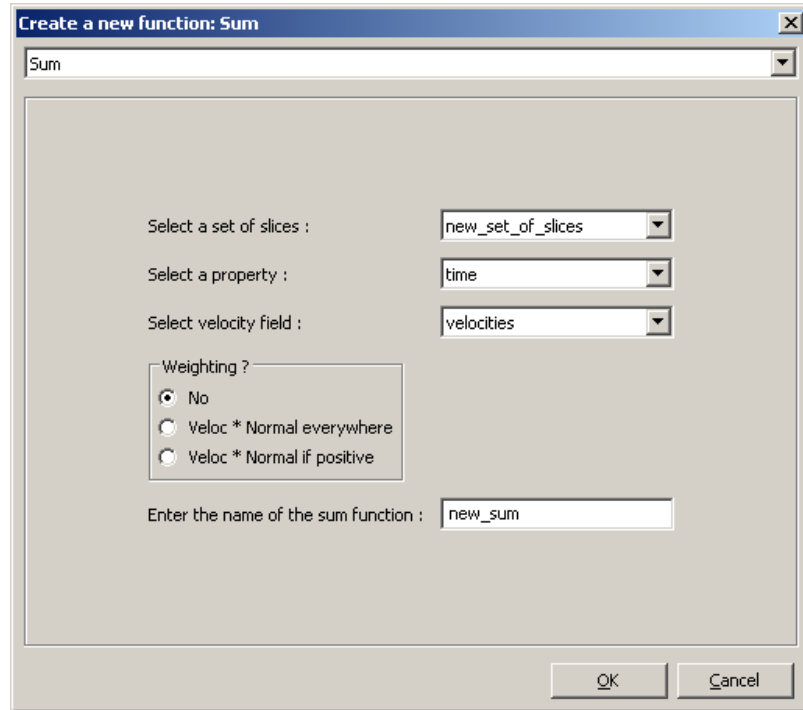

To calculate the sum function of a property, you need to specify which set of slices will be used and to select a property. You have also to give a name to the new function.

If you want to weight the sum in function of the local velocity, don't forget to select the velocity field. Additional information on weighting is available at the end of Chapter 4 (see § 4.7.3).

You will obtain the evolution of the sum of a property along the slices. If you visualize this function, you find on the X axis the index of the slice, and on the Y axis, the property α :

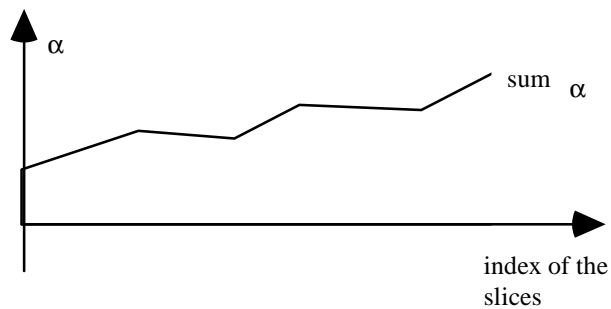



4.5.2.2 THE "MEAN & STANDARD DEVIATION" FUNCTION

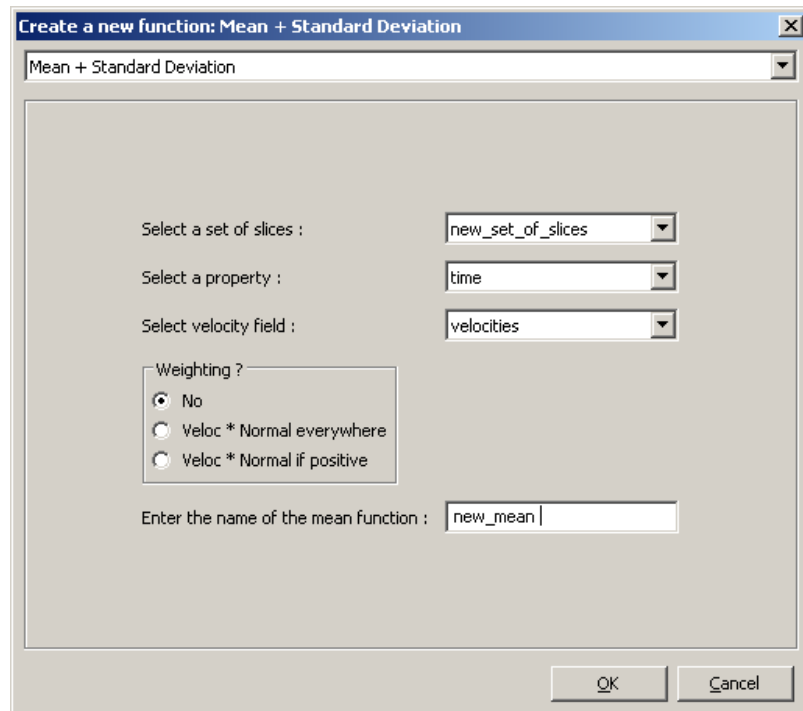

To calculate the mean and the standard deviation of a property, you need to specify which set of slices will be used and to select a property. You have also to give a name to the new function.

If you want to weight the mean and the standard deviation in function of the local velocity, don't forget to select the velocity field. Additional information on weighting is available at the end of Chapter 4 (see § 4.7.3).

You will obtain two curves : one for the evolution of the mean of a property along the slices, and the second, for the evolution of the standard deviation. If you visualize these functions, you find on the X axis the index of the slice, and on the Y axis, the property α :

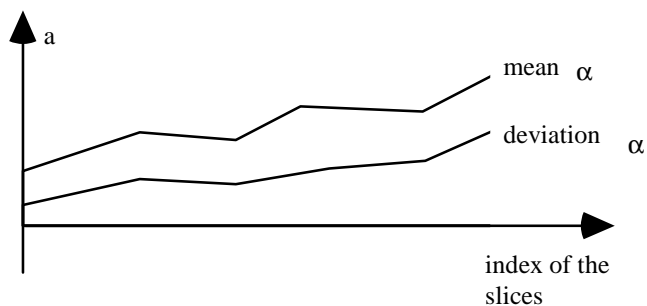



4.5.2.3 THE "CORRELATION" FUNCTION

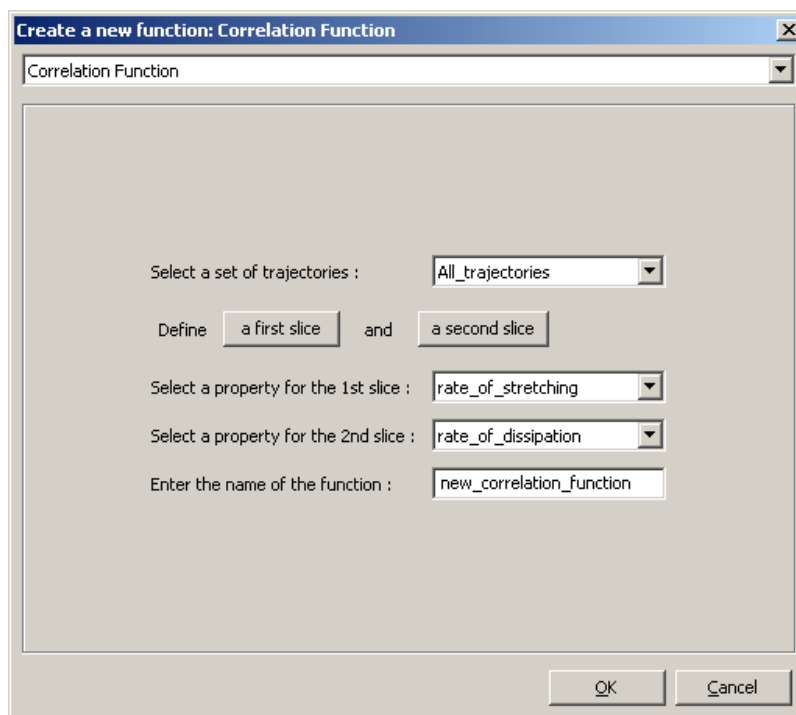

To analyze a possible correlation between two properties in two slices, you have first to select exceptionally **a set of trajectories**. Second, you define two slices by clicking successively on the "a first slice" and "a second slice" buttons. Third, you specify the properties associated to each slices. Finally, you give a name to this new function.

If you want to visualize this function, on the X axis, you have the property associated to the first slice, and on the Y axis, the property associated to the second slice :

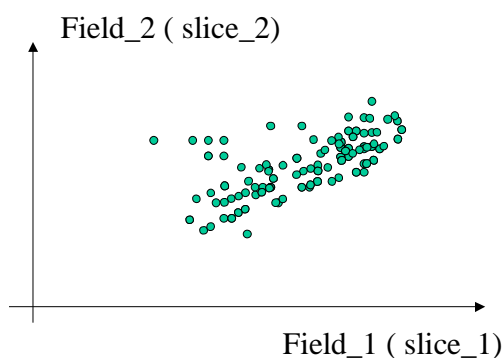



4.5.2.4 THE "PROBABILITY" FUNCTION

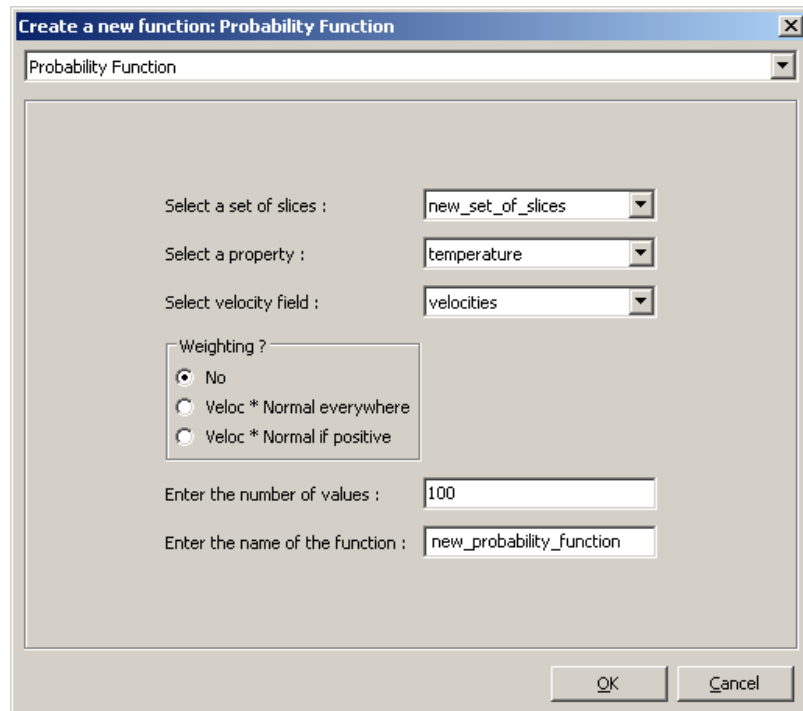

To calculate the evolution of the probability function (also named distribution function) of a property, you need to specify which set of slices will be used and to select a property. Don't forget to enter the number of values to represent this function and to give it a name.

If you want to weight the function depending on the local velocity, don't forget to select a velocity field (see § 4.7.3 for more information).

You will obtain a probability function for each slice of the set. If you visualize this function for a given slice, you find on the X axis the property, and on the Y axis, the probability :

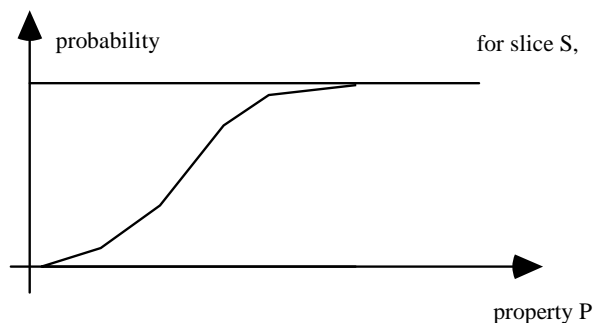



4.5.2.5 THE "AUTO-CORRELATION ON CONCENTRATION" FUNCTION

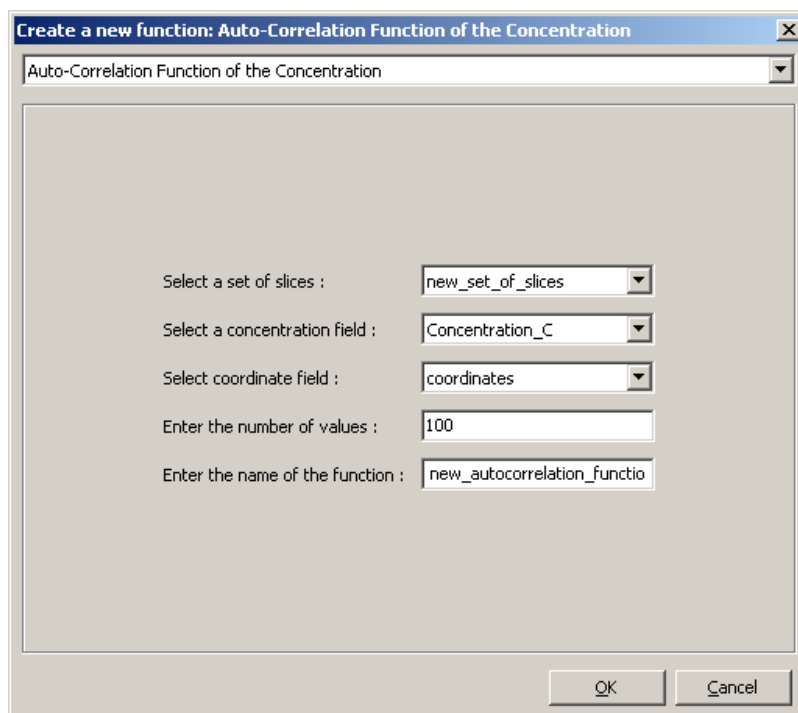

To calculate the evolution of the auto-correlation function of the concentration, you need to specify which set of slices will be used. You must select a coordinate property that will serve to calculate the distance between pairs of points in a slice and you must also select a concentration field.

Don't forget to specify the number of values necessary to represent the auto-correlation function. You have also to give a name to the new function.

You will obtain an auto-correlation function for each slice of the set. If you visualize this function for a given slice, you find on the X axis the distance, and on the Y axis, the auto-correlation function of the concentration :

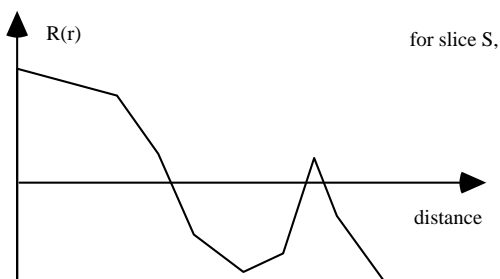



4.5.2.6 THE "DISTANCE DISTRIBUTION" FUNCTION

Create a new function: Distance Distribution

Distance distribution

Select a set of slices : new_set_of_slices

Select coordinate field : coordinates

Evaluate distance distribution

between all pairs of points

between pairs of neighboring points

for distance between 0 and 0

Enter the number of values : 100

Enter the name of the function : new_distribution_function

OK Cancel

To calculate the evolution of the distribution function of distances between material points, you need to specify which set of slices will be used. You must select a coordinate property that will serve to calculate the distance between pairs of points in a slice. Don't forget to enter the number of values to represent the distribution function. You have also to give a name to the new function.

Finally you have the possibility to choose between two methods :

- the first determines the distance distribution between all pairs of points. The maximum distance measured will be about the size of the flow domain, if the flow domain is closed.
- the other determines the distance distribution only for pairs of points that are close neighbors. The maximum distance measured, for a closed flow domain, will be :

$$\text{Max. distance} \approx 2 \sqrt[3]{V/n} ,$$

where V is the volume of the flow domain and n , the number of material points. The search of neighboring points will be done only for distance between 0 and a value specified by the user. It is recommended to choose a value greater than the maximum distance evaluated above.

In all cases, it is recommended to have V/n identical, if one wants to compare different flow domains or set-ups on a same flow domain.



You will obtain a distribution function for each slice of the set.

If you visualize this function for a given slice, you find on the X axis the distance, and on the Y axis, the distribution function :

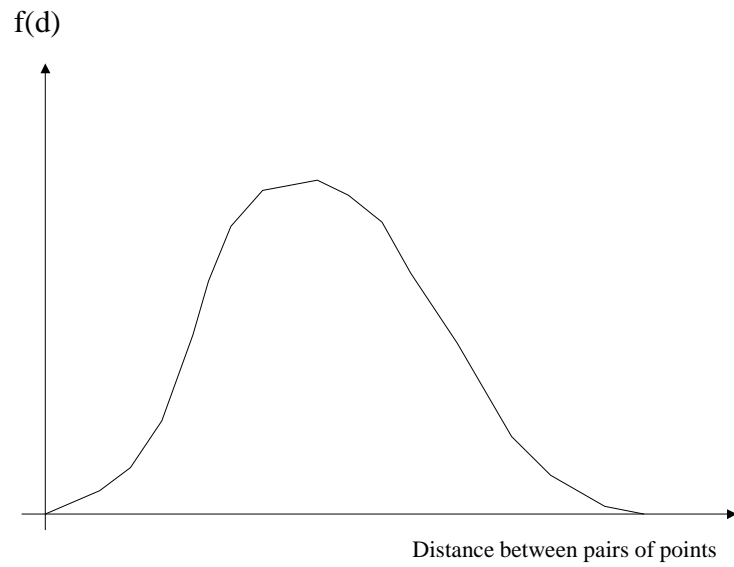



4.5.2.7 THE "DISTRIBUTION IN ZONES" FUNCTION

To calculate the evolution of the distribution of material points initially concentrated in a box, you need to specify two set of slices : the first one contains points coming from the real distribution, the second one contains points coming from an optimal distribution.

Next, you must select a coordinate property used to evaluate in which zones are included the points. Eventually, the user must specify in an ascii file the coordinates of the center of the zones. The format of this file is as follows ; on each line, there are the three coordinates (X,Y,Z) of one center. If the flow domain is 2D, the Z is set to zero.

```
+0.0000000e+00 +0.0000000e+00 +0.0000000e+00
+0.0000000e+00 +0.0000000e+00 +0.0000000e+00
+0.0000000e+00 +0.0000000e+00 +0.0000000e+00
```

With this function, we will obtain for each slice :

- for each zone, the evolution of the deviation of the real distribution (compared to optimal distribution); if one wants to save the function, the filename containing this curve is built like this: [prefix]_zon[zone index].crv

$$\delta(\text{zone } Z) = \frac{\text{nbc}(Z)}{\text{nbtot}} - \frac{\text{nbo}(Z)}{\text{nbtot}} \quad \text{with } \delta(Z) \in [-1;+1]$$



where $nbc(Z)$ ($nbo(Z)$) is the number of points of the real (optimal) distribution included in zone Z , and $nbtot$ is the total number of points in the real distribution.

If $\delta(\text{zone } Z)$ is zero, that means that the right number of points is included in zone Z .

If $\delta(\text{zone } Z)$ is negative, that means that the number of points included in zone Z is smaller than the optimum : there is a lack of points in that zone.

If $\delta(\text{zone } Z)$ is positive, that means that the number of points included in zone Z is larger than the optimum : there is an excess of points in that zone.

- the evolution of the global deviation of the real distribution (compared to optimal distribution); if one wants to save the function, the filename containing this curve is built like this: `[prefix]_zonGI.crv`

$$\delta_g = \frac{1}{2} \sum_{Z=1}^{nbzones} |\delta(Z)| \quad \text{with } \delta_g \in [0;+1]$$

- additional properties are also evaluated, but only available through the 'save functions' option. We will save in csv files (one file per slice_index), the zones partitioning, the deviation from optimal distribution, and the concentration of points in each area of the flow domain. If you want to see those fields, enter Polydata, read the mesh and select 'convert old csv files', enter the name of csv file and ask to save them in files readable by your graphic post-processor.

The concentration of 'real' points will be evaluated like this : for each point X of the optimal distribution, we determine the number of points of the real and optimal distributions included in a sphere of radius R and center X . The concentration at point X will be :

$$c(X) = \frac{nbr}{nbr + nbo} \quad \text{with } c(X) \in [0;+1]$$

where nbr = number of points of the real distribution $\subset \text{sphere}(X, R)$, and nbo = number of points of the optimal distribution $\subset \text{sphere}(X, R)$.

If the sample size method chosen by the user is the "automatic evaluation", the radius of the sphere is evaluated as follows. First we determine the smallest box that surrounds all the points of the optimal distribution. Next, we calculate its volume V . A typical distance between points is $d = \sqrt[3]{V / nbi}$, where nbi is the number of instants. Eventually, the radius of the sphere is set to $3d$.

However, if the sample size method chosen by the user is the "User specified" one, the user can impose its own value for the radius (that must be a positive real).



4.5.2.8 ARITHMETIC OPERATION ON SUM FUNCTIONS

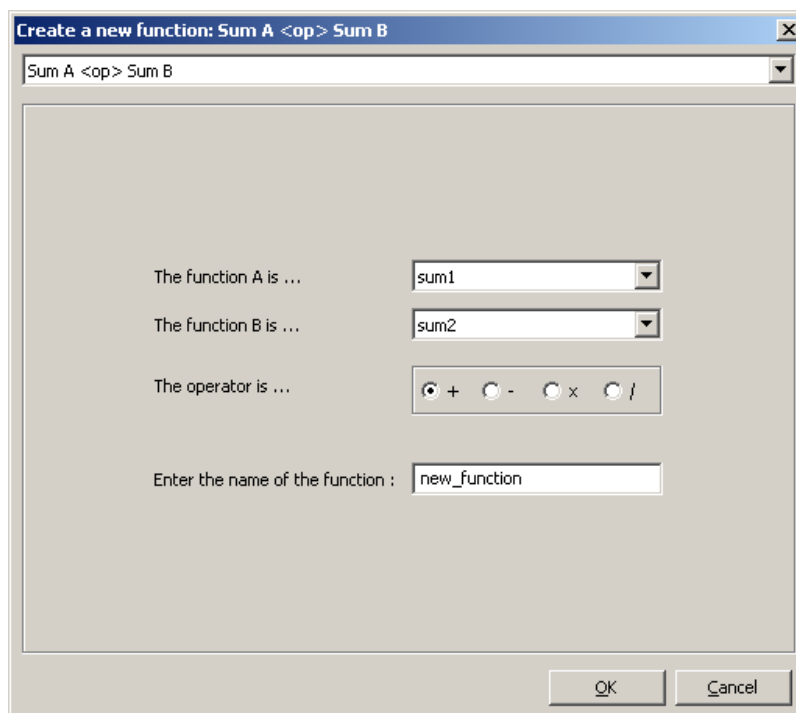

With this method, it is possible to combine two sum functions with an arithmetic operator (addition, multiplication, division and subtraction). Select the two sum functions, the operator and enter the name of the new function.

The calculation will be done like this : first, we define a list of x values, distributed linearly along the X axis and enclosed between the X minimum and the X maximum of the two functions. Second, for each x value, we search for the y value of the two functions :

$$y1 = \text{function1}(x) \ \& \ y2 = \text{function2}(x).$$

The y value of the result function corresponding to x will be :

$$y = y1 \ \langle \text{operator} \rangle \ y2.$$

You will find an example of use of this method in Addendum B.



4.5.2.9 SMOOTHING ON FUNCTIONS

Dialog box titled "Create a new function: Smoothing".

Select a function to smooth : function

Type

- Equal smoothing
- Centered smoothing
- Upwind smoothing
- Downwind smoothing

Parameters

Nb. of left neighbors : 1

Nb. of right neighbors : 1

Nb. of iterations : 1

Enter the number of values : 100

Enter the name of the function : new_smoothed_function

Buttons: OK, Cancel

First, select the function to smooth. Then select the kind of smoothing you want, and specify some parameters; we will explain that below. You must also enter the number of values to represent the smoothed function (a good practice is to use the same number of values that represent the data function). You have also to give a name to the new function.

The type of the result function will be the same than that of the data function. It is impossible to smooth a function that is already a smoothed function !

The method of smoothing is the following : to calculate one value of the result function, we calculate the mean of values that surround it in the data function. This process can be iterated several times.

The calculation of the mean can be weighted in different ways (type of smoothing).



With an equal smoothing, the current Y-value and every neighbor have the same weight :

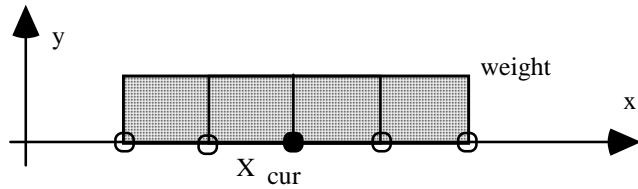

With a centered smoothing, the current Y-value has the highest weight, and the weight decreases linearly as the distance to the current X-value increases :

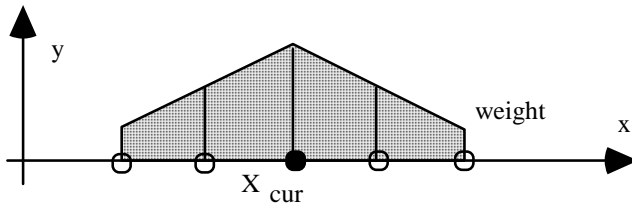

With the upwind smoothing, we look first at the Y-value of the farthest neighbor. We weight more the size (to the left or the right size of the current X-value) with the highest Y-value :

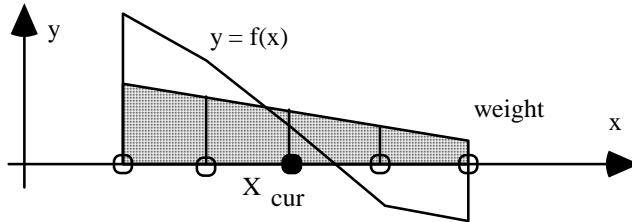

With the downwind smoothing, we look first at the Y-value of the farthest neighbor. We weight more the size (to the left or the right size of the current X-value) with the lowest Y-value :

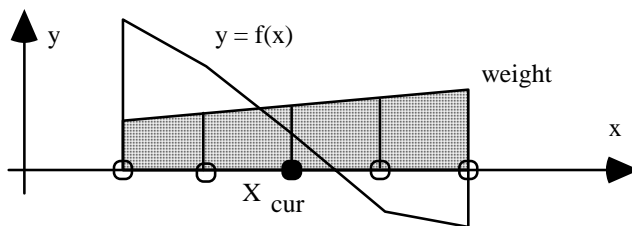

In general, we obtain a good result with a centered smoothing and with the following parameters : 2 neighbors at left, 2 at right and 2 iterations.



4.5.2.10 THE "DENSITY OF PROBABILITY" FUNCTION

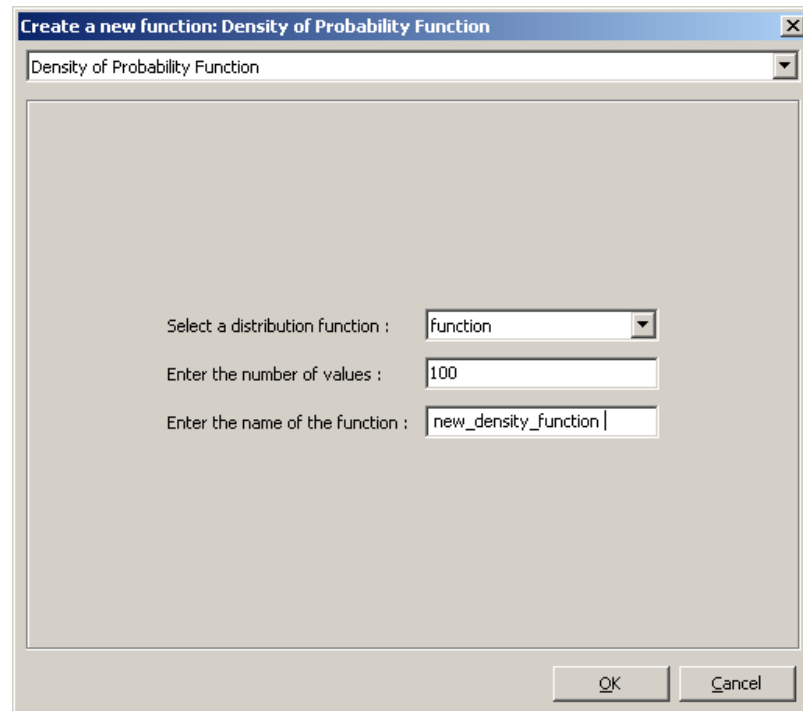

To calculate the evolution of a density of probability function, you need to specify which probability function to use. You must enter the number of values to represent such a function (a good practice is to use half the number of values that represent the probability function). You have also to give a name to the new function.

As there exists a list of probability functions (one for each slice of a sorted list), you will obtain a density of probability function for each slice S :

$$f(\alpha, S) = \frac{\partial P(\alpha, S)}{\partial \alpha}$$

If you visualize this function for a given slice, you find on the X axis the property values (the property has been chosen earlier when the probability function has been defined), and on the Y axis, the density of probability :

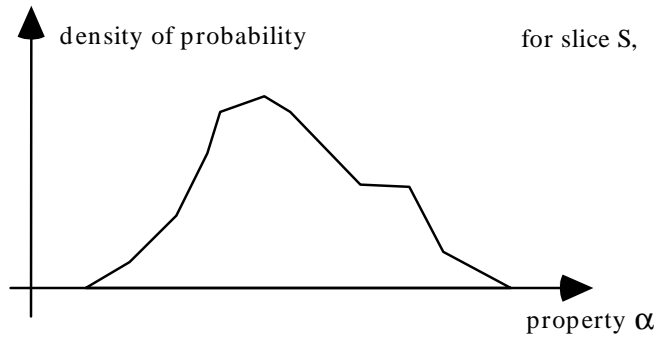

In order to avoid wiggles, it is a good practice to smooth the probability function before the calculation of the density of probability. And, in general, it is also necessary to smooth the density of probability function before visualisation.

4.5.2.11 THE "PERCENTILES" FUNCTION

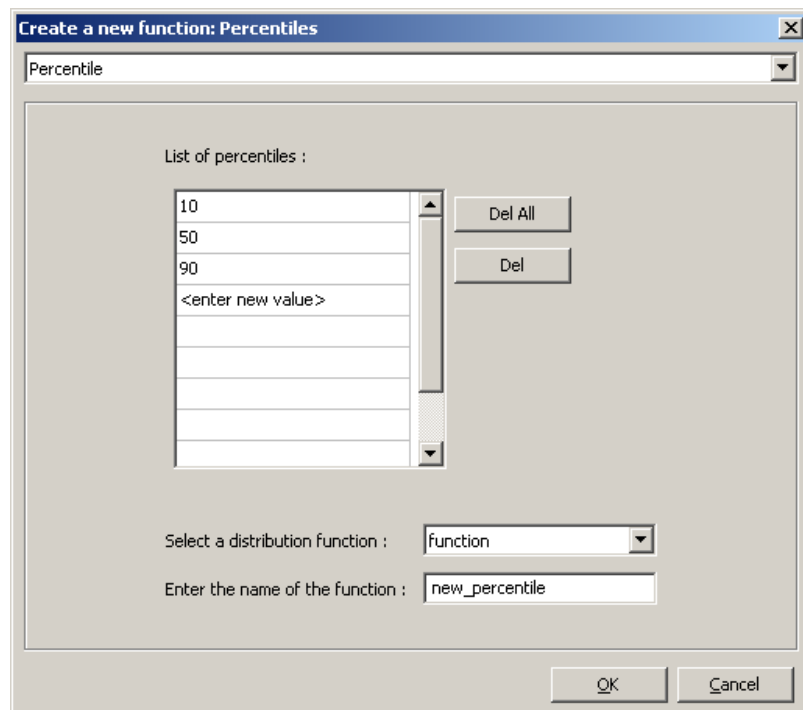

To calculate the evolution of percentiles, you need to specify which probability function to use. You must define a list of percentiles and also give a name to the new function.



To add a percentile to the list (ranged from 0 to 100), enter a value in the box, in the line tagged "<enter new value>" and then hit <CR>. To delete one percentile, select it in the list, and then click on the "Del" button.

As there exists a list of probability functions (one for each slice of a sorted list), you will obtain the evolution of a percentile along the slices (one curve for each percentile). If you visualize all the percentiles, on the X axis, you have the index of the slice, and on the Y axis, the value of the property (chosen earlier when the probability function has been defined) :

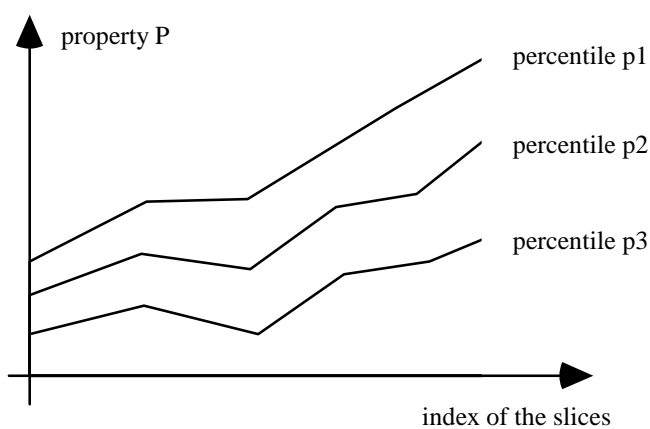



4.5.2.12 THE "HISTOGRAMS" FUNCTION

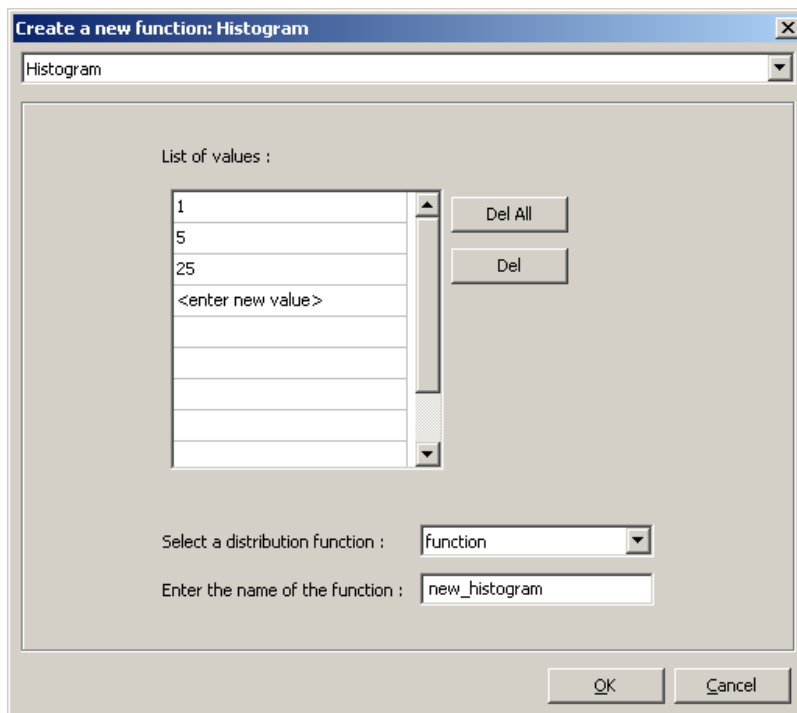

To calculate the evolution of histograms, you need to specify which probability function to use. You must define a list of intervals by introducing a set of values; one by one, enter a value in the box, in the line tagged "<enter new value>" and then hit <CR>. To delete one value, select it in the list, and then click on the "Del" button. You have also to give a name to the new function.

As there exists a list of probability functions (one for each slice of a sorted list), you will obtain a histogram function for each slice. If you visualize this function for a given slice, on the X axis, you have the specified intervals of values (the corresponding property has been chosen earlier when the probability function has been defined), and on the Y axis, the percentage of instants of the slice having a property value in each interval :

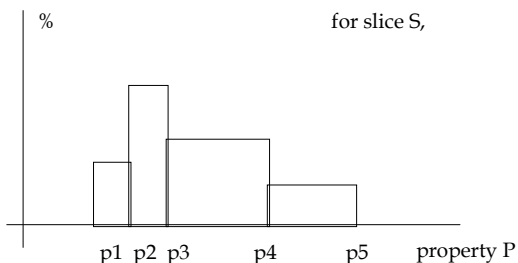



4.5.2.13 THE "SEGREGATION SCALE" FUNCTION

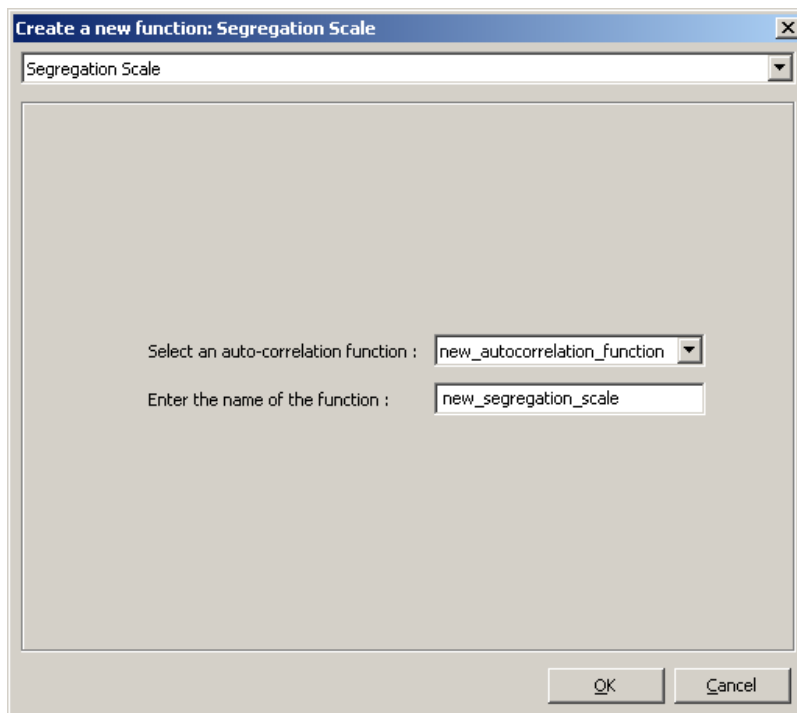

To calculate the evolution of the segregation scale, you need to specify which "auto-correlation on concentration" function to use. You have also to give a name to the new function.

As there exists a list of auto-correlation functions (one for each slice of a sorted list), you will obtain the evolution of the segregation scale along the slices. If you visualize this function, on the X axis, you have the index of the slice, and on the Y axis, the value of the segregation scale :

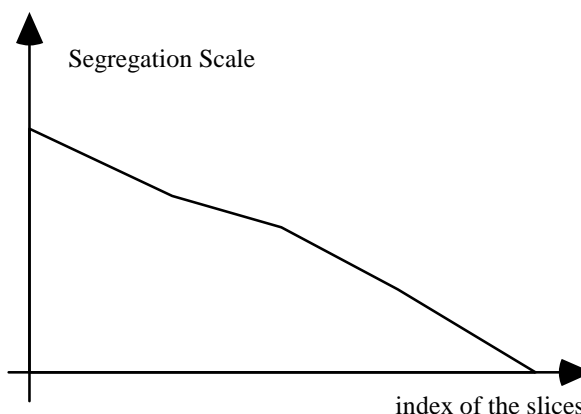



4.5.2.14 THE "DEVIATION" FUNCTION

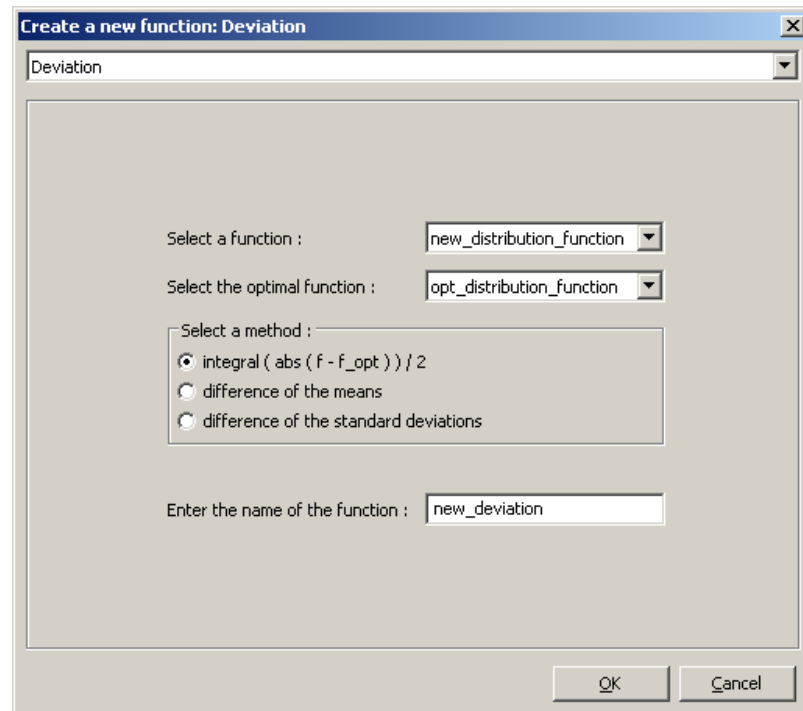

This function will allow you to calculate the gap existing between two density of probability functions. The second one is supposed to be an "optimal" function. Three different methods exist to evaluate this deviation δ :

a) $\text{integral (abs (f - f}^{\text{opt}})) / 2$

$$\delta(\text{idx}) = \frac{1}{2} \int_{-\infty}^{+\infty} |f(s, \text{idx}) - f^{\text{opt}}(s, \text{idx})| ds.$$

b) difference of the means :

$$\delta(\text{idx}) = \bar{s} - \bar{s}^{\text{opt}}$$

c) difference of the standard deviations :

$$\delta(\text{idx}) = \bar{\sigma} - \bar{\sigma}^{\text{opt}}$$



where

$$\bar{s}(\text{idX}) = \int_{-\infty}^{+\infty} f(s, \text{idX}) s \, ds$$

and

$$\bar{\sigma}^2(\text{idX}) = \int_{-\infty}^{+\infty} f(s, \text{idX}) (s - \bar{s})^2 \, ds$$

This distribution index defined in chapter 2 corresponds to the result of the first method.

In all cases, you have to specify the density of probability function of the real distribution and the density of probability function of the optimal one. Next, you select a method, and eventually you give a name to the new function.

You will obtain the evolution of the deviation along the slices. If you visualize this function, on the X axis, you have the index of the slice, and on the Y axis, the value of the deviation :

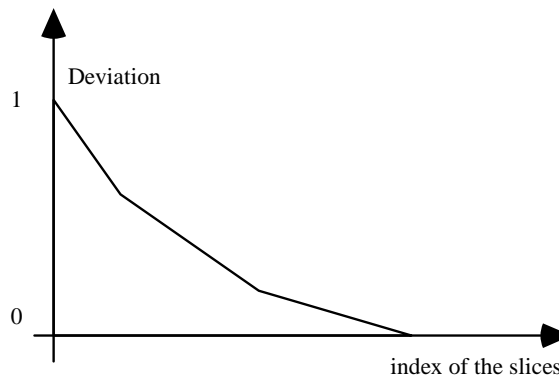

To simulate and analyze the distribution of matter, a series of steps are necessary to perform. Those are explained in detail in addendum A.



4.5.2.15 THE "POINTS CONCENTRATION DEVIATION" FUNCTION

Points Concentration Deviation

Select a set of slices :

Select coordinate field :

Perfect points concentration

Sample radius :

Minimum number of neighboring points :

The points in a given slice are distributed in a ...

Enter the name of the function :

OK Cancel

This function will allow you to calculate the “deviation” of points concentration in a slice compared to a perfect points concentration. This deviation will be evaluated for each slice of the selected set of slices. The user must select a set of slices and a coordinate field. Moreover, the user must introduce the points concentration for a perfect distribution in each slice. This perfect distribution may be evaluated as follows:

- a) For a 3D open flow domain, we perform a slicing in space, in the direction of the flow; thus each slice will be a surface. We assume that each slice has the same perfect points concentration that is equal to the number of points in a slice S divided by the area of the part of the slice S that cuts the flow domain.
- b) For a 3D closed flow domain, we perform a slicing in time; thus each slice will be a volume. We assume that each slice has the same perfect points concentration that is equal to the number of points tracked divided by the volume of the flow domain.
- c) For a 2D open flow domain, we perform a slicing in space, in the direction of the flow; thus each slice will be a line. We assume that each slice has the same perfect points concentration that is equal to the number of points in a slice S divided by the length of the part of the slice S that cuts the flow domain.



d) For a 2D closed flow domain, we perform a slicing in time; thus each slice will be a surface. We assume that each slice has the same perfect points concentration that is equal to the number of points tracked divided by the area of the flow domain.

In order to evaluate the points concentration in each slice, around each point, one must specify the radius of the sample; all points in the neighborhood of point \mathbf{x} at a distance smaller than this radius will be taken to evaluate the local points concentration at position \mathbf{x} . This radius must be chosen carefully; if it is too small, no points will be found and the local concentration will not be relevant; if it is too large, we will evaluate a global concentration that will be identical for all points in the slice, and that will not change from slice to slice. A first estimation is to take as the radius a tenth of a typical distance in the slice (diameter of a rotor or of a screw, for example).

The user can also specify the minimum number of points needed to evaluate the points concentration at a position \mathbf{x} ; the default is set to 3. If the number of neighboring points is smaller than this minimum, we increase progressively the radius (for that position \mathbf{x} only), until we have that right number of neighbors.

Next, the user must not forget to specify the dimensionality of the samples. If the samples are straight line segments (dim=1), surfaces (dim=2) or volumes (dim=3). This is needed to evaluate the local points concentration $\phi(\mathbf{x})$, as explained in § 2.3.3.

The deviation δ_p in a slice S is evaluated as follows:

$$\delta_p(S) = \sqrt{\frac{\sum_{i=1}^N [\phi(\mathbf{x}_i) - \phi_p]^2}{N}},$$

where N is the number of points in the slice S, the $\{\mathbf{x}_i\}$ correspond to the location of points i in the slice S and ϕ_p is the perfect points concentration.

Eventually, the user can give a name to the function.



4.5.3 NEW DISAGGLOMERATION FUNCTIONS

If you select the option "New Disagglomeration Functions" in the "STATISTICS" menu of the main window, you will see a window showing the list of functions that can be calculated on properties derived from properties linked to disagglomeration model :

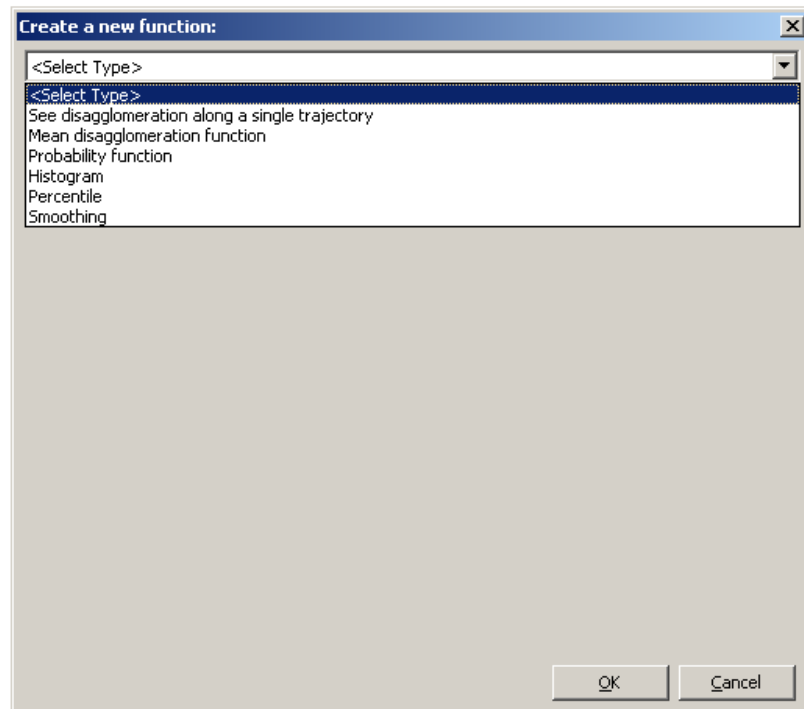

The first three functions are specific to disagglomeration model and are explained in the next pages, while the last three functions are identical to general statistics functions. For them, see explanations in § 4.5.2.9, § 4.5.2.11 and § 4.5.2.12.



4.5.3.0 THE "SEE DISAGGLOMERATION ALONG A SINGLE TRAJECTORY" FUNCTION;

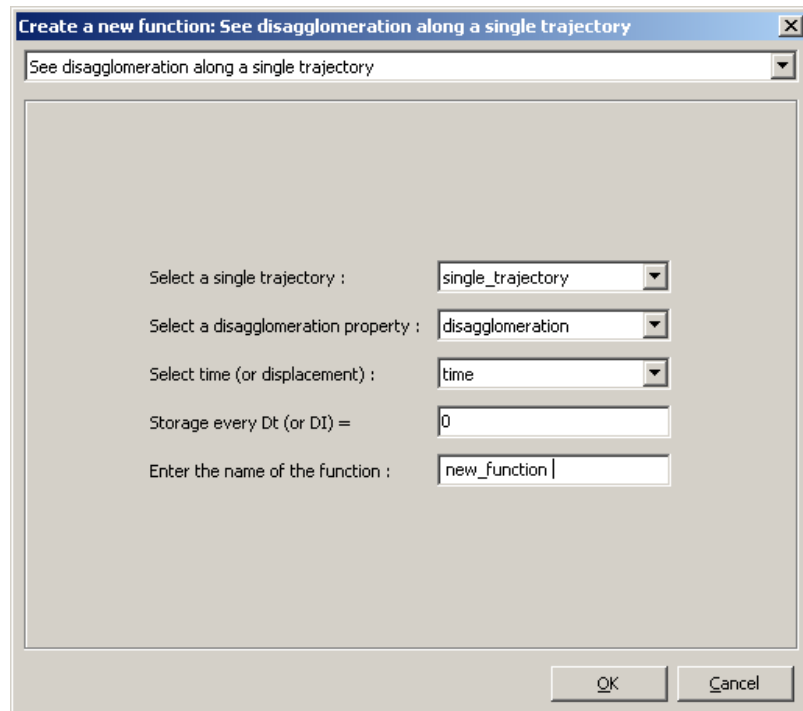

With this function, the user will see the time (or displacement) evolution of the disagglomeration property calculated along any trajectory he wants.

The user has to specify which single trajectory will be used, to select the disagglomeration property to see, and the time (or displacement). The user must also specify the time or space interval where the disagglomeration property will be stored. Eventually, the use gives a name to the new function.

If you visualize this function, you find on the X axis the size of agglomerates, and on the Y axis, the density of probability to find agglomerates of a given size. In this graph, you have a new function $y=f(x)$ for each time (or displacement) step :

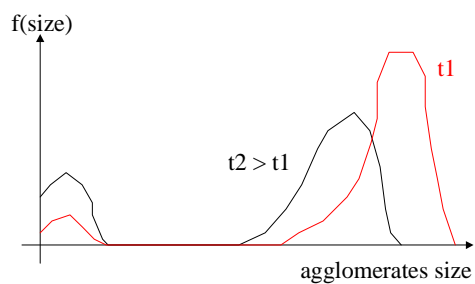



4.5.3.1 THE "MEAN DISAGGLOMERATION" FUNCTION

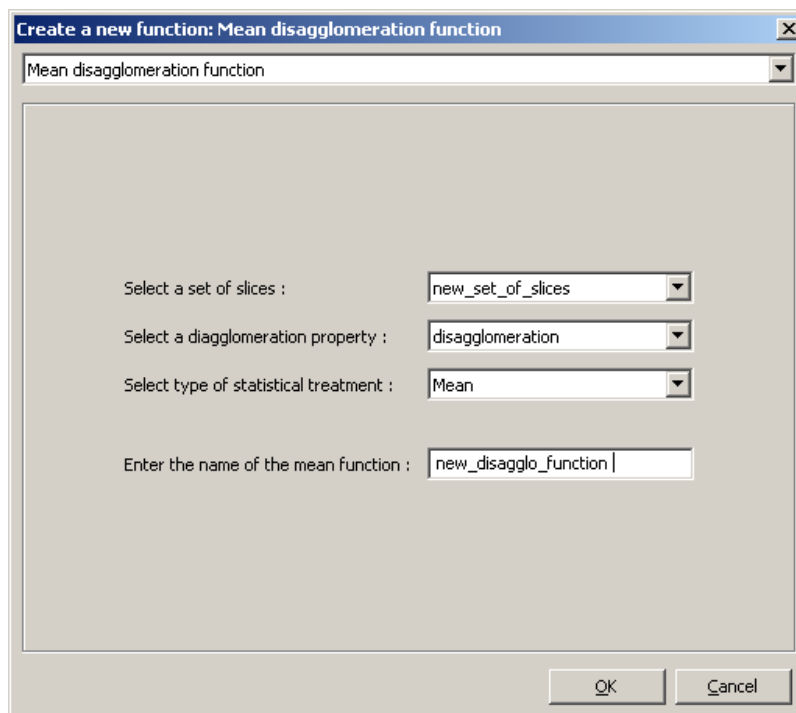

The user has to select a set of slices and a disagglomeration property. Different types of treatment are available : minimum, maximum, mean, standard deviation, standard deviation for values below the mean and standard deviation for values above the mean.

Eventually, the user gives a name to the new function.

With this function and the "min" treatment selected, one evaluates for each slice, a min disagglomeration function, based on the disagglomeration property known at each point included in the slice :

$$f_{\min}(s, \text{idx}) = \min\{f(s, \text{point } i)\}, \quad \forall \text{point } i \subset \text{slice idx}$$

With this function and the "max" treatment selected, one evaluates for each slice, a max disagglomeration function, based on the disagglomeration property known at each point included in the slice :

$$f_{\max}(s, \text{idx}) = \max\{f(s, \text{point } i)\}, \quad \forall \text{point } i \subset \text{slice idx}$$



With this function and the “mean” treatment selected, one evaluates for each slice, a mean disagglomeration function, based on the disagglomeration property known at each point included in the slice :

$$\tilde{f}(s, \text{idx}) = \frac{1}{n} \sum_{i=0}^n f(s, \text{point } i), \quad \forall \text{ point } i \subset \text{slice idx}$$

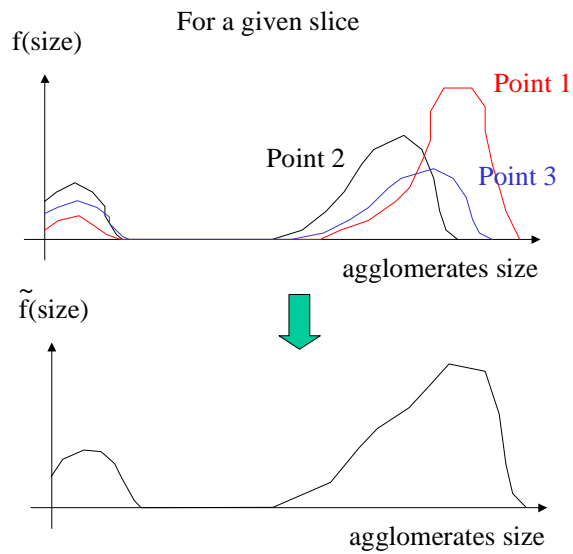

With this function and the “standard deviation” treatment selected, one evaluates for each slice, a standard deviation disagglomeration function, based on the disagglomeration property known at each point included in the slice :

$$\sigma_f(s, \text{idx}) = \sqrt{\frac{1}{n} \sum_{i=0}^n [f(s, \text{point } i) - \tilde{f}(s, \text{idx})]^2}, \quad \forall \text{ point } i \subset \text{slice idx}$$

With this function and the “standard deviation for values below the mean” treatment selected, one evaluates for each slice, another standard deviation disagglomeration function, based on the disagglomeration property known at each point included in the slice :



$$\sigma'_f(s, \text{idx}) = \sqrt{\frac{1}{n} \sum_{i=0}^{n'} [f(s, \text{point } i) - \tilde{f}(s, \text{idx})]^2}, \quad \forall \text{ point } i \subset \text{slice idx}$$

with $f(s, \text{point } i) \leq \tilde{f}(s, \text{idx})$

With this function and the "standard deviation for values above the mean" treatment selected, one evaluates for each slice, a last standard deviation disagglomeration function, based on the disagglomeration property known at each point included in the slice :

$$\sigma''_f(s, \text{idx}) = \sqrt{\frac{1}{n} \sum_{i=0}^{n''} [f(s, \text{point } i) - \tilde{f}(s, \text{idx})]^2}, \quad \forall \text{ point } i \subset \text{slice idx}$$

with $f(s, \text{point } i) \geq \tilde{f}(s, \text{idx})$

4.5.3.2 THE "PROBABILITY" FUNCTION

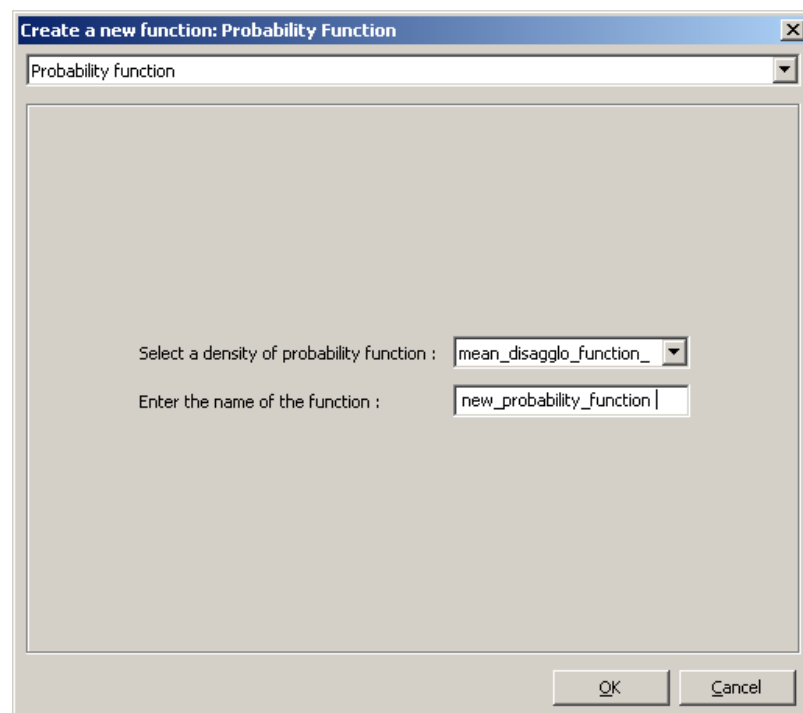

The user has to select a density of probability function and to give a name to the new function.



With this function, one evaluates for each slice idx , a probability function P as the integral of a density of probability function f on a property α :

$$P(\alpha, idx) = \int_{-\infty}^{\alpha} f(a, idx) da$$



4.6 THE HELP MENU

Two options are available in the Help menu : i) the “POLYSTAT User’s Guide (PDF)” item starts a *pdf* reader and opens the POLYSTAT manual; ii) the “About” item opens a new window giving information on the current release, on copyright and trademark information and also on third party attributions.

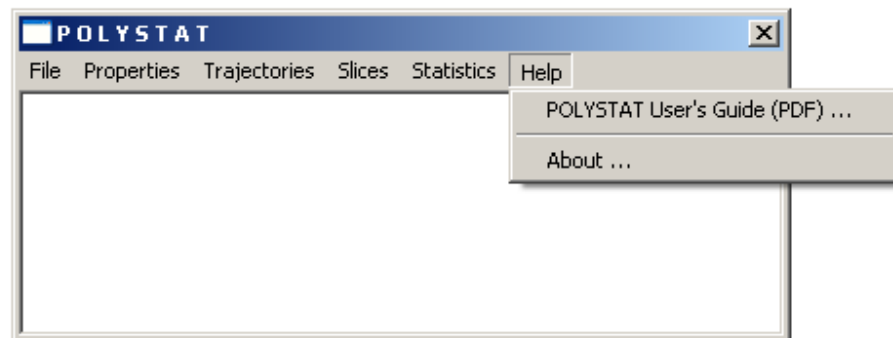



4.7 ADDITIONAL DEFINITIONS

4.7.1 THE SLICES

A slice is the set of instants of the trajectories that respect some specified condition. A condition is, for example, "the time t must be equal to 30 seconds", or "the position x must be included in the plane $10x + 2y - 3z + 6 = 0$ ", etc.. The general way to define a condition is the following : for a property P , the value of P must be included in a plane (this plane is defined by a position and a normal direction).

To define a slice, the following window appears :

The screenshot shows a dialog box titled "Define a slice". It contains a dropdown menu for "Select a property :" with "coordinates" selected. Below this, the text "For this property," is followed by three input fields labeled "1", "2", and "3" under the label "enter a value :". Below these are three more input fields labeled "4", "5", and "6" under the label "enter a direction :". At the bottom, there is a text input field "Enter the name of this slice :" with "new_slice" entered. There are "OK" and "Cancel" buttons at the bottom right.

First, you select a property on which the condition will apply. Second, you specify the plane to respect. To define it, enter the position in the rectangles 1 to 3, and the normal direction in the rectangles 4 to 6. Finally, enter the name of the slice.

If the selected property is a scalar, the value to respect is specified in the rectangle 1 (the rectangles 2 and 3 are set to zero). The normal direction must be set to $(1, 0, 0)$!



4.7.2 THE ZONES

A zone is an interval of values for a specified property. For example, for a vector property (as the position), we have to define the two extreme corners of a box.

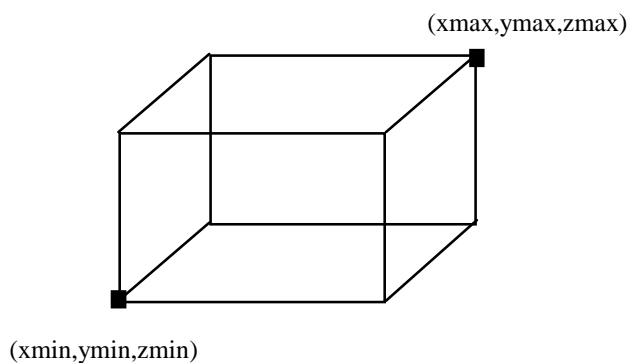

If the property is a scalar, we define the minimum and the maximum values of the interval.

To define a zone, the following window appears :

The screenshot shows a dialog box titled "Define a zone". It contains the following elements:

- A dropdown menu labeled "Select a property:" with "coordinates" selected.
- An "enter" button below the dropdown.
- Three input fields for "the minimum value:" containing the numbers 1, 2, and 3.
- Three input fields for "the maximum value:" containing the numbers 4, 5, and 6.
- A text field labeled "Enter the name of this zone:" containing the text "new_zone".
- "OK" and "Cancel" buttons at the bottom right.

First, you select a property on which we define the zone. Second, you specify the interval; enter the minimum value in the rectangles 1 to 3, and the maximum value in the rectangles 4 to 6. Finally, enter the name of the zone.

If the selected property is a scalar, the minimum value is specified in the rectangle 1 and the maximum value is specified in the rectangle 4 (the rectangles 2, 3, 5 and 6 are set to zero).



4.7.3 WEIGHTING

The slicing must be defined on a coordinate field, in order to weight a property by the velocity.

The general formula for the sum, the mean and the standard deviation are :

$$\Sigma_{\alpha}(\text{slice } i) = \sum_j \alpha_j \omega_j ,$$

$$\bar{\alpha}(\text{slice } i) = \sum_j \alpha_j \omega_j / \sum_j \omega_j ,$$

$$\sigma_{\alpha}(\text{slice } i) = \sqrt{\sum_j (\alpha_j - \bar{\alpha})^2 \omega_j / \sum_j \omega_j} ,$$

where the index 'j' indicates the j-th instant of slice i, α_j is the value of α at instant j, and ω_j is the weight at instant j.

To calculate the probability function $P(\alpha)$, we sort the set of pairs :

$$\{ (\alpha_j, \omega_j) \text{ with } \alpha_j \leq \alpha_{j+1}, \text{ for } j = 1, \text{ to } n_{bi} \}$$

where n_{bi} is the number of instants in slice i.

Finally the probability to find a value α below α_j is :

$$P(\alpha \leq \alpha_j) = \frac{\sum_{k=1}^j \omega_k}{\sum_{k=1}^{n_{bi}} \omega_k}$$

The value of the weight is :

- a) if (no weighting) : $\omega_j = 1,$
- b) if (weighting everywhere) : $\omega_j = (\mathbf{v}_j \cdot \hat{\mathbf{n}}_i)$
- c) if (weighting when $\mathbf{v}_j \cdot \hat{\mathbf{n}}_i$ positive) : $\omega_j = (\mathbf{v}_j \cdot \hat{\mathbf{n}}_i)$ if $(\mathbf{v}_j \cdot \hat{\mathbf{n}}_i) > 0$
 $= 0,$ otherwise,

where $(\mathbf{v}_j \cdot \hat{\mathbf{n}}_i)$ is the dot product of the velocity at instant j by the normal of the slice i.



ADDENDUM A.- THE SIMULATION OF THE DISTRIBUTION

Let's suppose the flow to be 3D, steady state, in a closed domain.

To perform the analysis of the distribution, the following steps are necessary.

- 1) We calculate the flow (velocity and pressure) .
- 2) We calculate in the mixing task 1 the real distribution :
we suppose the material points to be initially concentrated in a small volume. We have to calculate their trajectory for a given time interval. We store these trajectories in files named real_0001 to real_000X (for example).
- 3) We calculate in the mixing task 2 the optimal distribution :
we suppose the material points to be initially distributed in all the flow domain. We have to calculate their trajectory for a very short time interval (infinitesimal amount of time). We store these trajectories in files named opti_0001 to opti_000X.
- 4) In POLYSTAT, we read the files real_0001 to real_000X, and the files opti_0001 to opti_000X.
- 5) We define two sets of trajectories : the first one, named "real_set" contains all the trajectories from the real_* files. the second one, named "opti_set" contains all the trajectories from the opti_* files.
- 6) We define two sets of slices : the first one, named "real_slicing", is a slicing on the time (N slices, every Δt seconds), for the "real_set" set of trajectories. The second one, named "opti_slicing", is one slice defined for time $t=0$ and on the "opti_set" set.
- 7) We define two Distance Distribution functions : the first one, named "real_distribution", is based on the "real_slicing" set of slices. The second one, named "opti_distribution", is based on the "opti_slicing" set of slices.
- 8) We define one Deviation function, to calculate the deviation of the real distribution ("real_distribution" function) from the perfect distribution ("opti_distribution" function).



ADDENDUM B.- THE GLOBAL EFFICIENCY OF STRETCHING

Let's suppose the flow to be 2D, steady state, in a closed domain.

We will explain how we can calculate the time evolution of the global efficiency of stretching (see chapter 2 for the definition of this parameter).

For example, for the linear stretch, at time t , this efficiency is :

$$\langle\langle e_\lambda \rangle\rangle (\mathbf{M}, t) = \int_{\Omega_0} \ln(\lambda) d\Omega \Big/ \int_{\Omega_0} \int_0^t D dt' d\Omega$$

To calculate such a parameter, the following steps are necessary :

- In the mixing files are calculated the stretching $\ln(\lambda)$ and the dissipation rate D along trajectories.
- First, we have to define, in POLYSTAT, a new property, the cumulated dissipation, which is the time integration of the dissipation rate :

$$\langle D \rangle = \langle D \rangle (\mathbf{X}, t) = \int_0^t D(\mathbf{X}, t') dt'$$

This new parameter depends on the material point and on time.

- We perform a slicing on the time (N slices, every Δt seconds).
- We calculate the sum function of the stretching $\ln(\lambda)$:

$$S_{\ln(\lambda)} (\mathbf{M}, t) = \int_{\Omega_0} \ln(\lambda) d\Omega$$

- We calculate the sum function of the cumulated dissipation $\langle D \rangle$:

$$S_{\langle D \rangle} (t) = \int_{\Omega_0} \langle D \rangle d\Omega$$

- Finally, we divide the two sum functions to obtain the global efficiency of stretching :

$$\langle\langle e_\lambda \rangle\rangle (\mathbf{M}, t) = S_{\ln(\lambda)} (\mathbf{M}, t) / S_{\langle D \rangle} (t)$$



ADDENDUM C.- ADAPTIVE MESHING AND MIXING TASK

The 65th example explains the procedure to follow in the case adaptive meshing has been used to evaluate the flow field. Indeed, two limitations of the mixing module forbid to use meshes whom some parts have been sub-divided. Firstly, in case of transient simulations, the mesh of the flow domain can/will change with time : new elements and new nodes are created/deleted. Secondly, as the mesh is refined locally, non-conformity appears: sub-divided elements are adjacent to non sub-divided elements. As the tracking of material points does not allow such cases, we propose the following procedure :

- In POLYDATA, during the definition of the flow task, we ask for the output of CSV results files.
- In POLYFLOW, we evaluate the transient flow, using adaptive meshing; at each time step, a CSV file is generated that contains the current flow field.
- In POLYDATA, we perform a conversion of the csv files into new POLYFLOW results files onto a new uniformly refined mesh (the mesh of the flow domain will remain constant in time) ; at the end of this step, we have a new mesh and a set of res files (1 res file per time step) compatible with this new mesh.
- In POLYDATA, we define a mixing task, based on the new mesh and the new results files.
- In POLYFLOW, we compute the trajectories of a set of material points.
- In POLYSTAT, we perform a statistical analysis on these trajectories.



ADDENDUM D.- SLIDING MESH TECHNIQUE AND MIXING TASK

When sliding mesh technique is used, two limitations of the mixing module forbid to use the computed flow field to perform tracking of material points. Firstly, in case of transient simulations, the mesh can/will change with time (position of the nodes). Secondly, the mesh is non-conform. As the tracking of material points does not allow such cases, we propose the following procedure :

- In your mesher application, define a mesh constituted of different sub-domains for the flow domain: one subdomain is fixed, while the other(s) is (are) rotating. In the figure below, the flow domain is composed of disconnected sub-domains 1 to 3. The subdomain #1 is fixed, while subdomain #2 is rotating with the left cam and subdomain #3 is rotating with the right cam. The internal part of the cams are not be meshed.

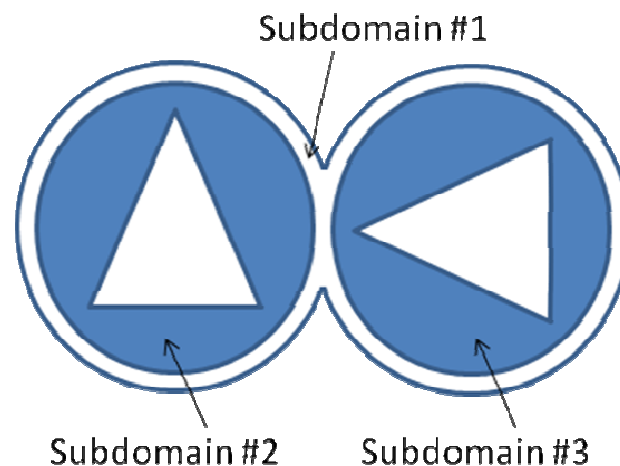

- In POLYDATA, during the definition of the flow task, we use the sliding mesh technique; we define motion of the rotating sub-domains. Connected boundary conditions are needed between tangential boundaries of fixed and rotating sub-domains. Moreover, we ask for the output of CSV results files.
- In POLYFLOW, we evaluate the transient flow, using sliding mesh technique; at each time step, a CSV file is generated that contains the current flow field.
- In your mesher application, define a new mesh, where the flow domain is conform, and with new sub-domains overlapping the flow domain and corresponding to the moving parts (as if we had to define sub-domains for the mesh superposition technique). The position of the moving parts must correspond to the initial position of the moving parts used for the simulation of the flow field!

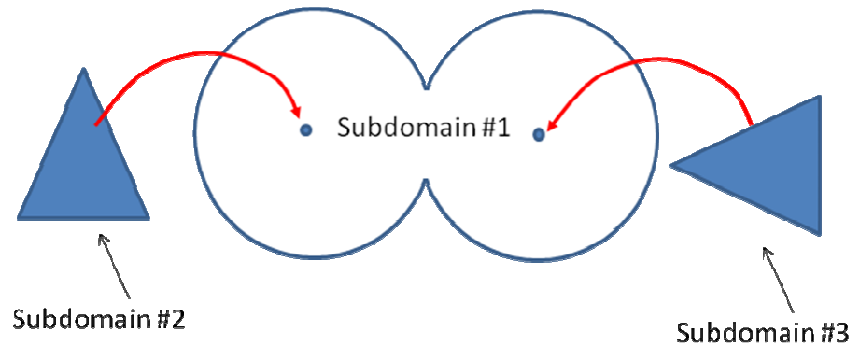

- In POLYDATA, we perform a conversion of the csv files into new POLYFLOW results files onto this new mesh (the mesh of the flow domain will remain constant in time) ; at the end of this step, we have a set of res files (1 res file per time step) compatible with the new mesh.
- In POLYDATA, we define a mixing task, based on the new mesh and the new results files.
- In POLYFLOW, we compute the trajectories of a set of material points.
- In POLYSTAT, we perform a statistical analysis on these trajectories.