

Part-Load Performances and Augmentation of Power for Aircraft Engines

- *volumetric efficiency, η_v* is affected by :
 - Density of the fresh charge at the cylinder intake,**
 - The pressure and the temperature of the outgoing burnt gas,**
 - Design of the intake and exhaust manifolds,**
 - The timing of the opening and closing of the intake and exhaust valves.**

Piston engine designers have to pay sufficient attention to these factors to achieve a high efficiency engine.

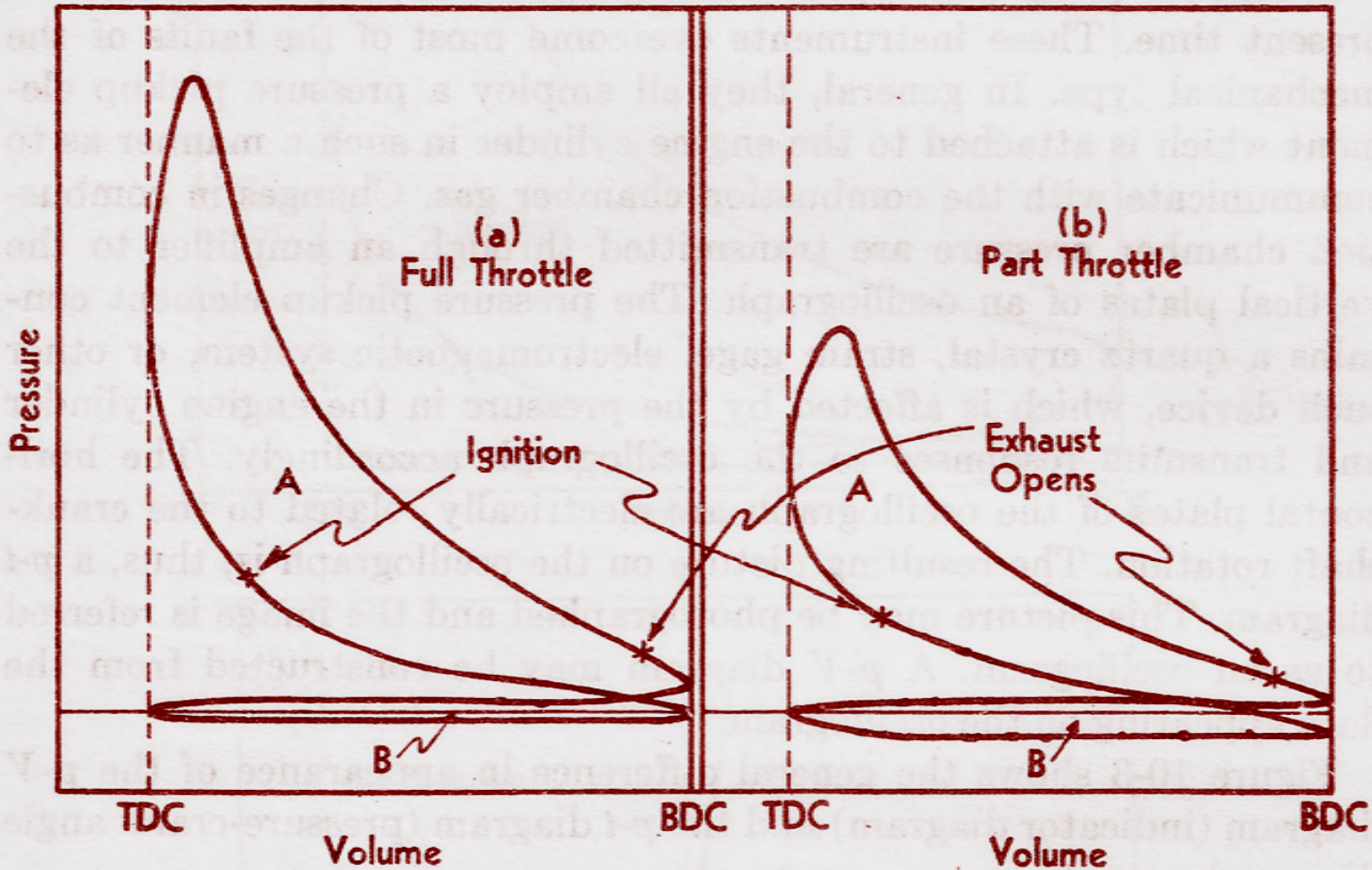

Comparison of typical indicator diagrams for a SI engine at full throttle and part throttle operation

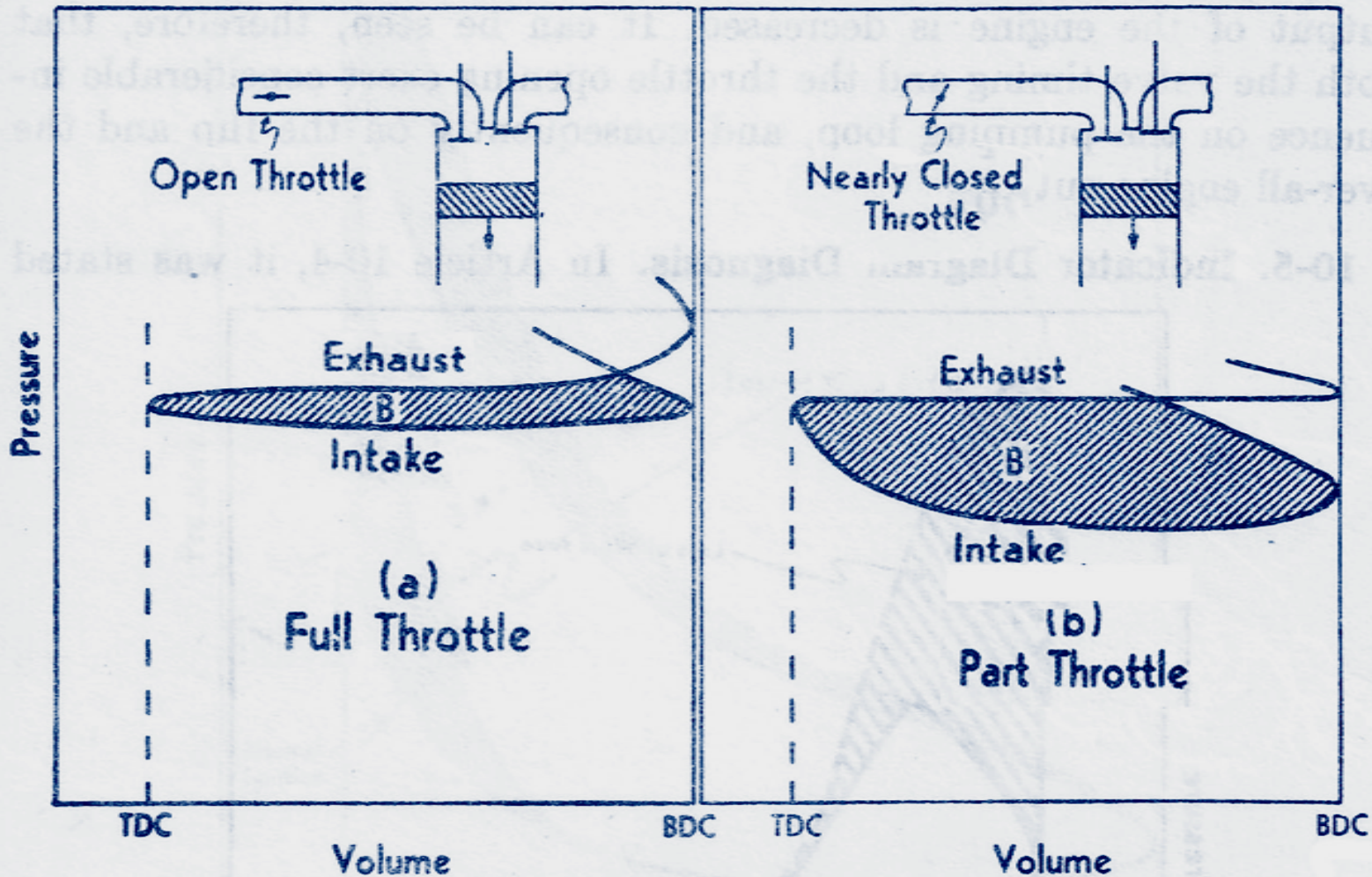

Comparison of full throttle and part throttle pumping loops of indicator diagram

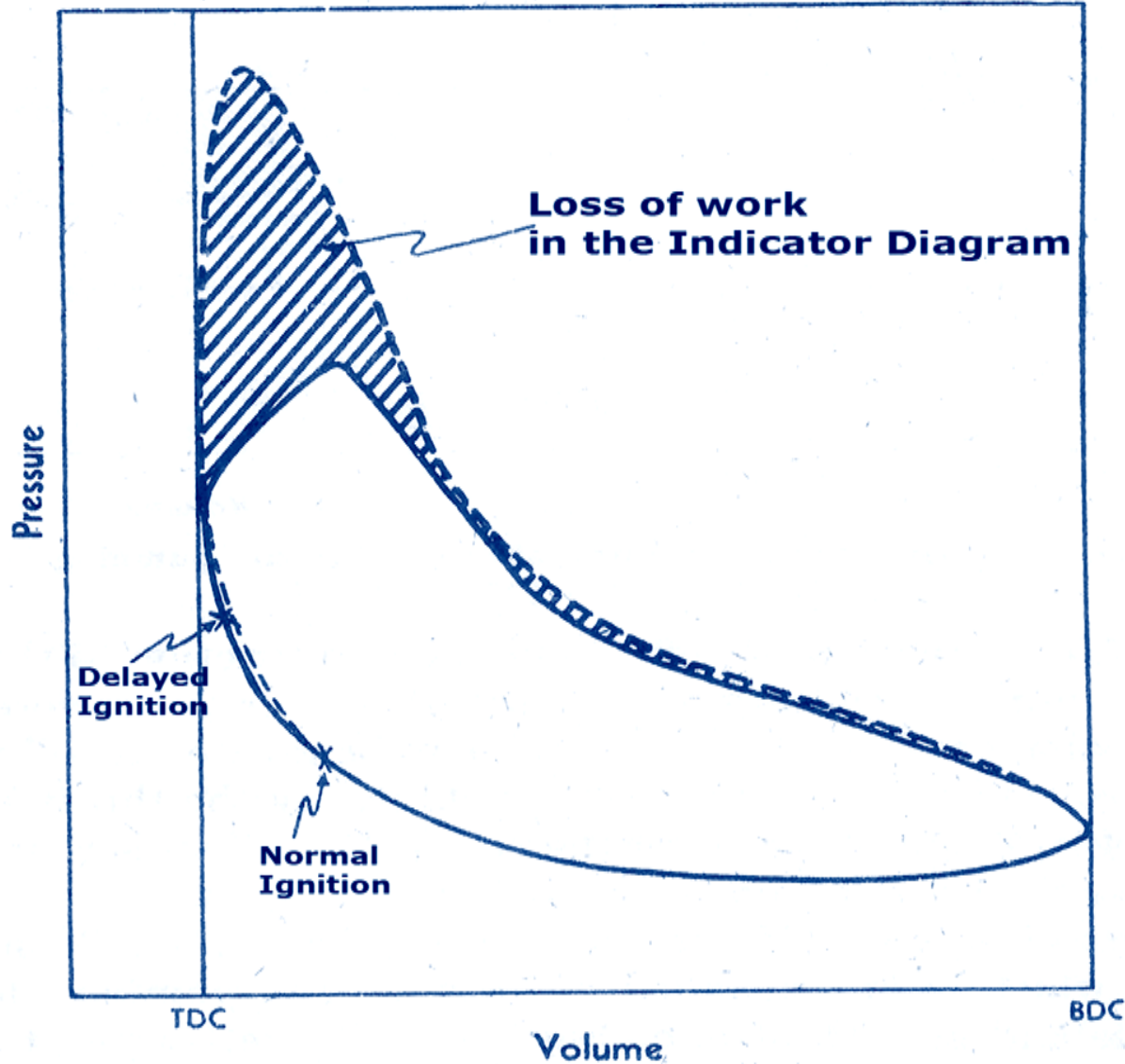

Delayed Ignition results in large loss of work done by the power stroke

Effect of delayed ignition on indicator diagram

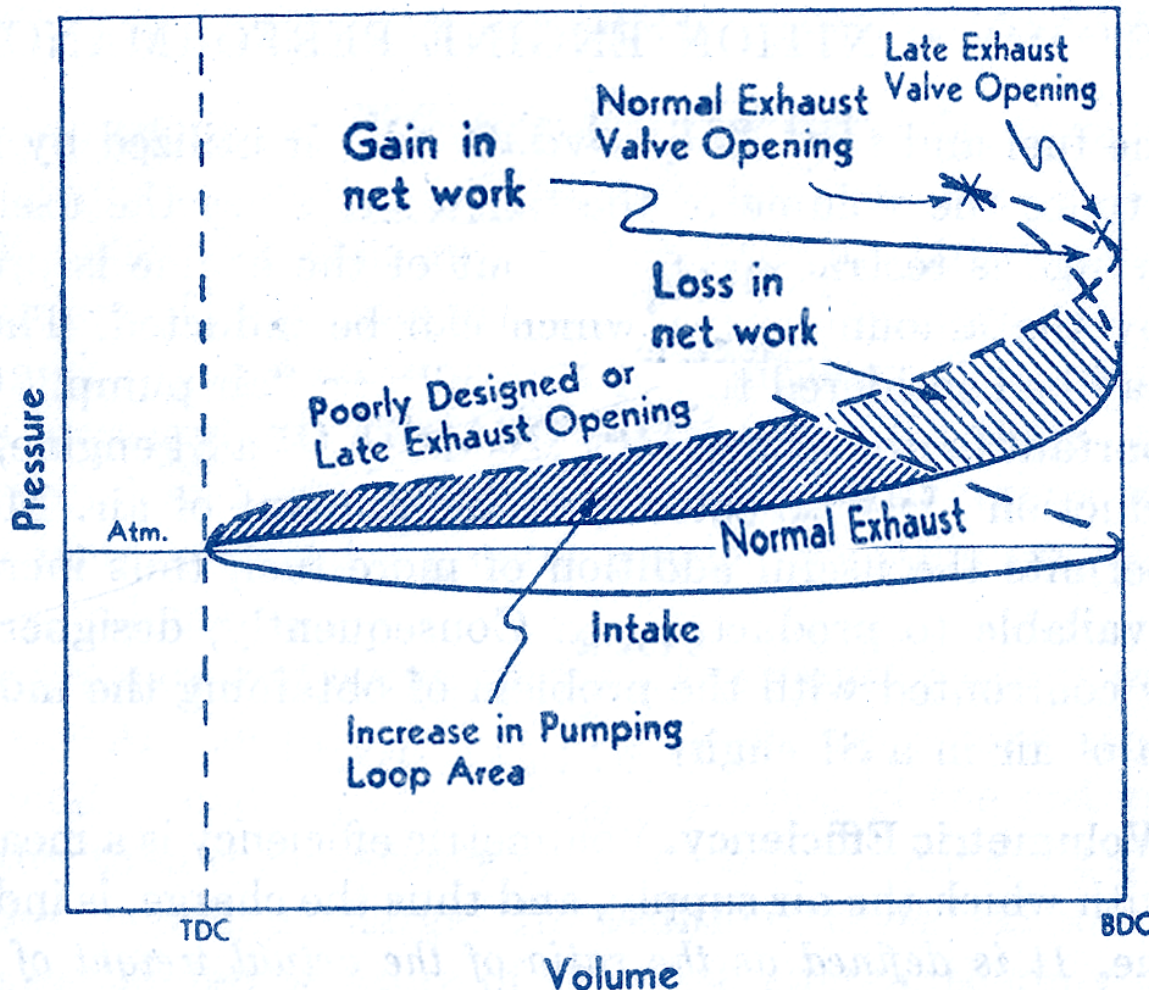

Effect of high exhaust back pressure

Late opening or poorly designed Exhaust Valve creates :

- 1) Loss of piston work
- 2) Increase of intake work
- 3) A small gain in work

Poor Intake design creates : More work in Intake operation

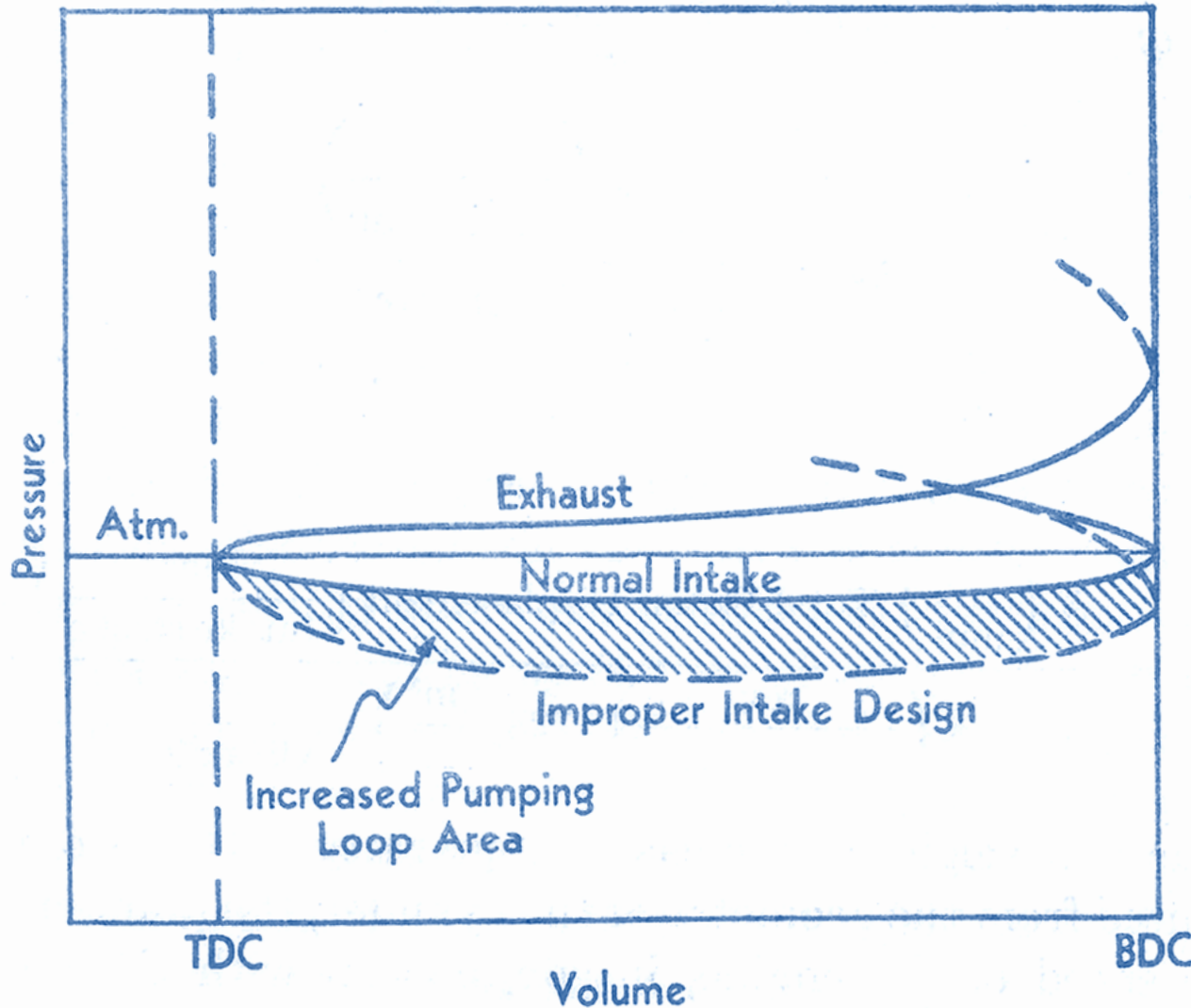

Effect of improper intake system design on i

Important performance factors are (a) heat release per unit mass of air and (b) quantity of charge (air + fuel mixture) per stroke.

- a) Heat release per unit mass of air (Heating value) depends upon both fuel chemical composition and the working fuel-air ratio.*
- b) Quantity of charge per stroke introduced into the cylinder directly controls the quantity of heat released and work done per cycle.*

- If a supercharger (a booster) is used, before the charge enters the cylinder, the cylinder is filled above ambient pressure and density, hence the weight or mass of air introduced per cycle is greater than in the unsupercharged case. The volume of operation remains same. So that with a volumetric efficiency applied (typically < 1), the nett work done would be higher than that of a naturally aspirated engine.

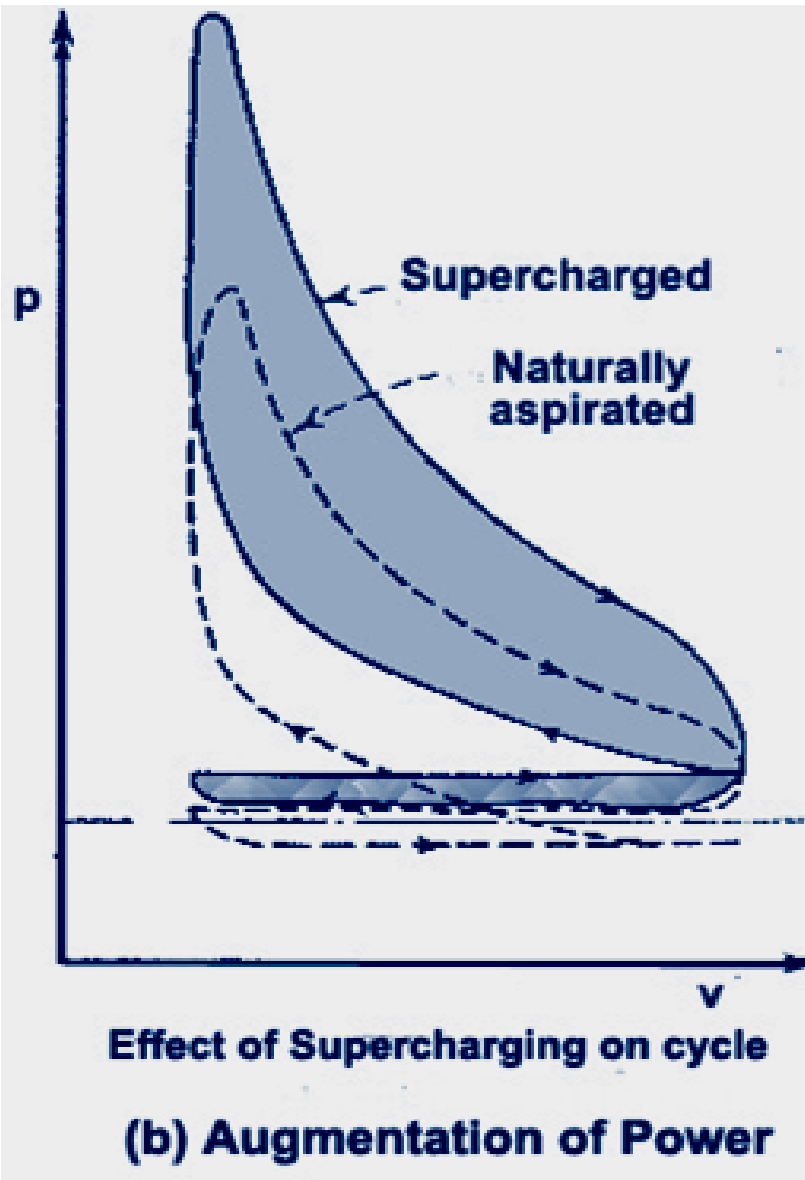

Compression pressure **maximum pressure**, and net area of the work diagram of the supercharged cycle have higher values than the corresponding items in the unsupercharged cycle. The fuel used is same and in the same manner.

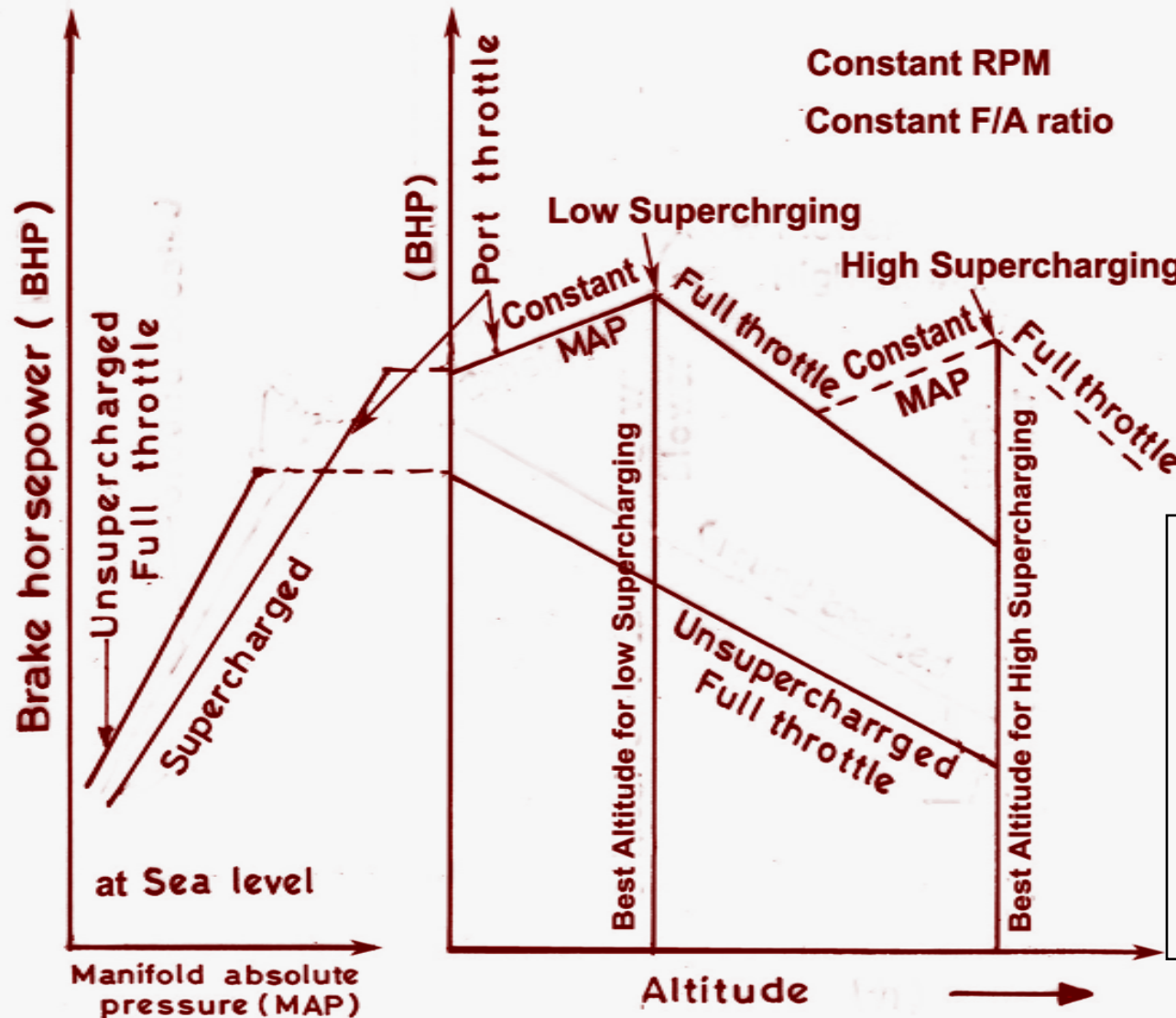

Fig. shows the effect of supercharging at sea level and at altitude.

Super-charging creates higher Inlet Manifold Absolute Pressure (MAP)

Supercharging.

- Additional work may be extracted from the exhaust gases by expanding them to atmospheric pressure through a turbine.
- The work output of the turbine goes to drive a centrifugal blower, called supercharger.
- As aircraft goes to altitude the atmospheric pressure is reduced, thereby increased supercharging is required to hold a design manifold pressure.
- In turbo supercharging the supercharger + turbine RPM is varied by adjusting the turbine discharge nozzle to produce the pressure ratio

The supercharger delivery pressure is given by:

$$\pi_{\text{supercharger}} = \frac{\text{pressure at turbo supercharger exit}}{\text{ram pressure in outside air scoop}}$$

This arrangement is can maintain constant engine BHP from sea level to a very high altitude. The operating altitude is determined by the maximum allowable RPM of the supercharger-turbine.

Supercharging Cycle – p-v diagram

The Compression and Turbine work are shown separately as they use separate working medium

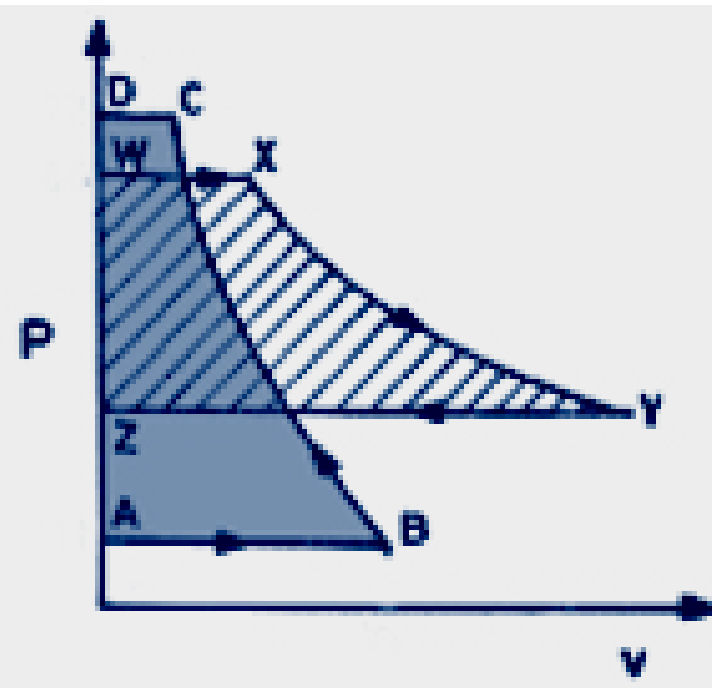

- 1) A-B – Intake to compressor system.
- 2) The compression line - BC,
- 3) The work required to compress is represented by the area ABCD.
- 4) The source of this work is, the turbine, which extracts energy from the outgoing mass of burned gas that has passed through the engine.
- 5) The turbine work (per unit mass of exhaust gas) is represented by the shaded area WXYZ.

Supercharging Cycle – p-v diagram

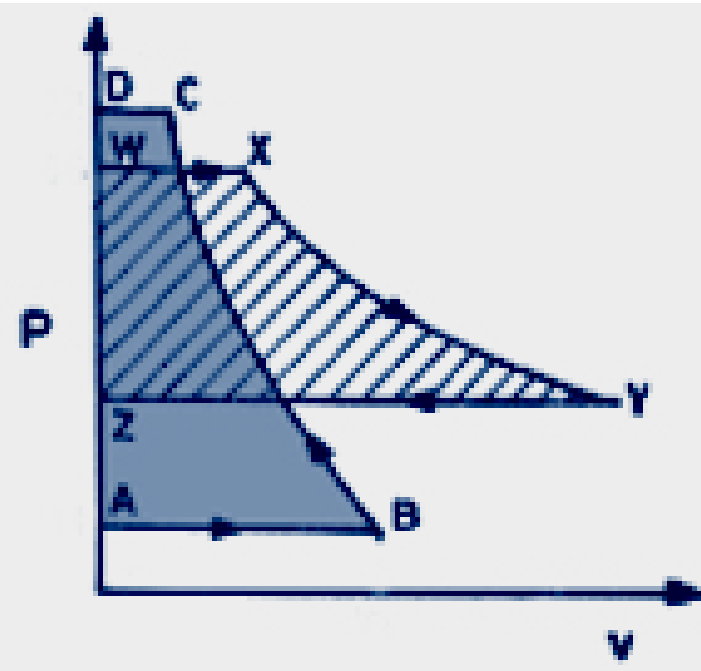

- 7) Exhaust gas enters the turbine along line WX, expanding along line XY, and being pushed out of the turbine along the path YZ.
- 8) If the turbine is used only to drive the compressor, areas ABCD (compressor work) and WXYZ (turbine work) must be equal, otherwise the turbo-compressor will speed up or slow down.
- 9) If the turbine work be excessive, the turbine discharge nozzle may be throttled, raising line YZ until area WXYZ again equals area ABCD

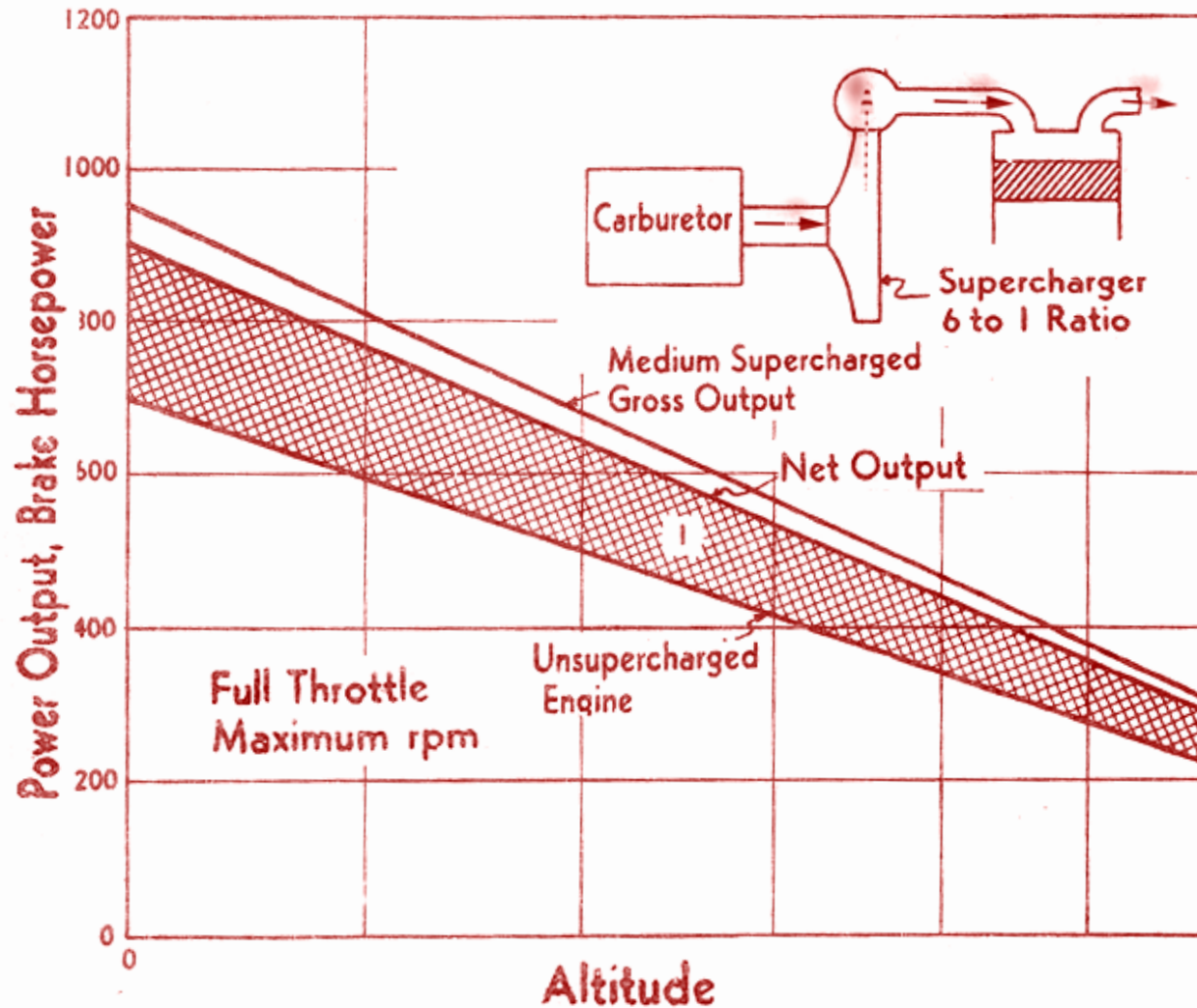

- BHP of an aircraft engine continuously goes down with the altitude.
- Supercharging restores power output
- High supercharging is used only for climb

Turbo-Supercharger with Inter-cooler

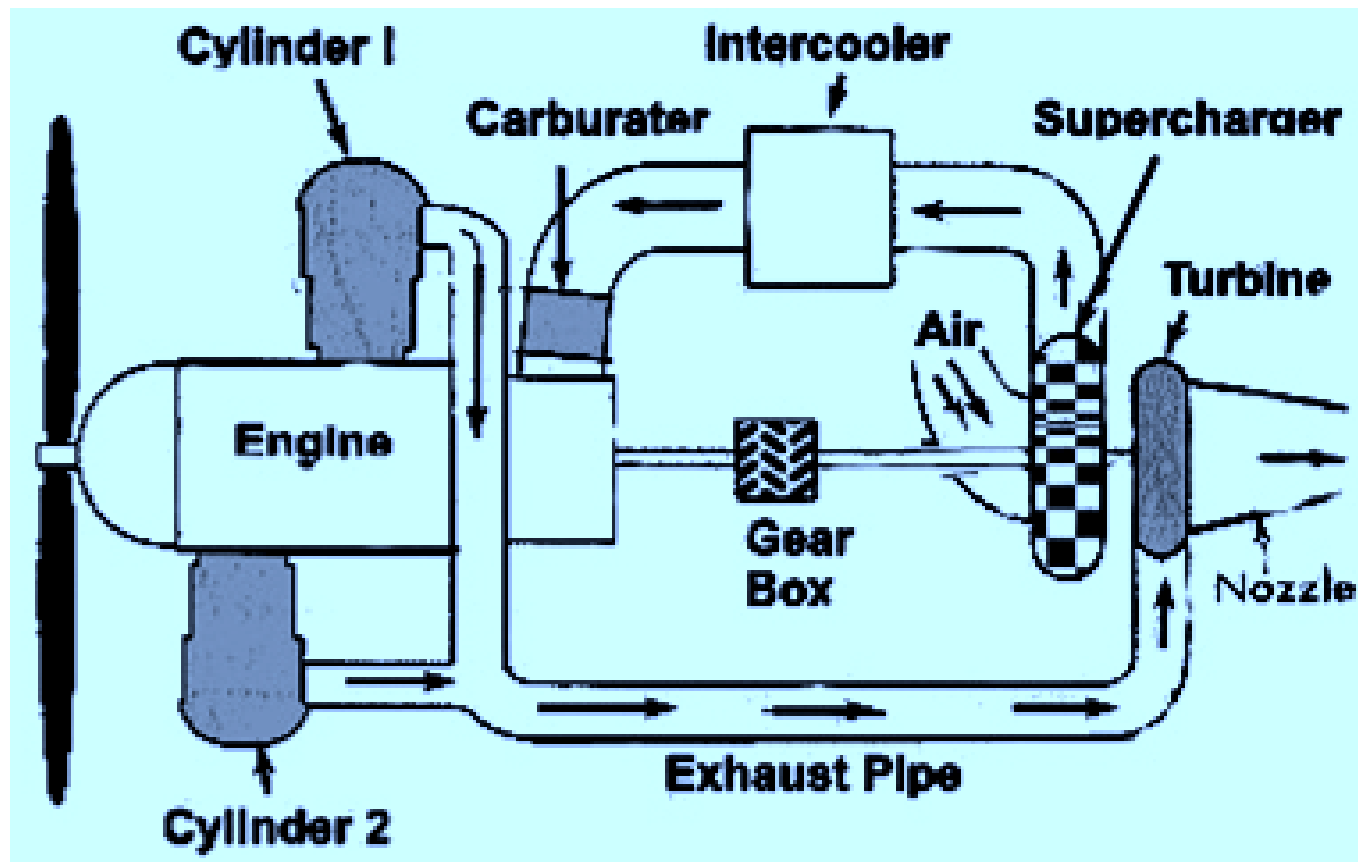

Superchargers may be :

- 1) Single stage supercharger
- 2) Two stage supercharger
- 3) Variable speed supercharger
(Atleast two speeds for high and medium supercharging)
- 4) Centrifugal flow machine (most used)
- 5) Axial Flow compressor

The next class :

Tutorial on IC Engines