

Modern Instrumental Methods of Analysis

J.R. Mudakavi

Dept. of Chemical Engineering
Indian Institute of Science, Bangalore

ANALYTICAL CHEMISTRY

ANALYTICAL SCIENCE

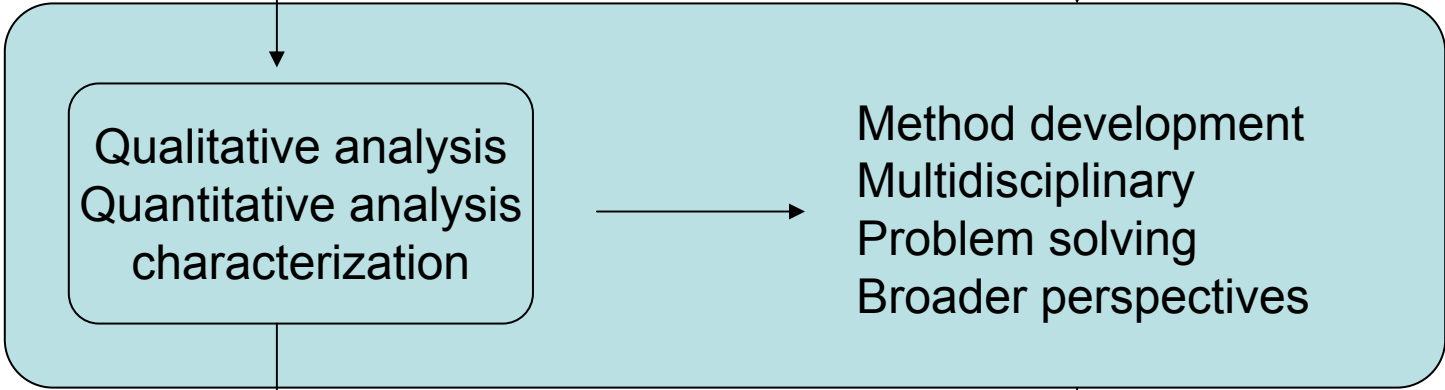
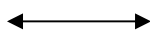

Tools

Tools

Qualitative schemes
Ions, organics, titrations
Gravimetry,
Limited physical properties
M.P, B.P, Viscosity

Classical & Modern
Instrumental techniques
Statistics, electronics
Computers

Routine Analysis

Cutting edge Technology

2. Analytical Chemistry in Action

2.1 Automobile exhaust analysis

Sub-ppb analysis of PAHS *↘ Polycyclic aromatic hydrocarbons*

2.2 APXS sensor on Mars

Analysis of soils and rocks on Mars by
Rutherford backscattering
X-ray fluorescence
Nuclear reactions

2.3 SPADNS Method for fluoride determination

Development of APHA standard Method
Interlaboratory and intralaboratory analysis
Development of standard Reference material(SRM)
Data handling – statistical evaluation

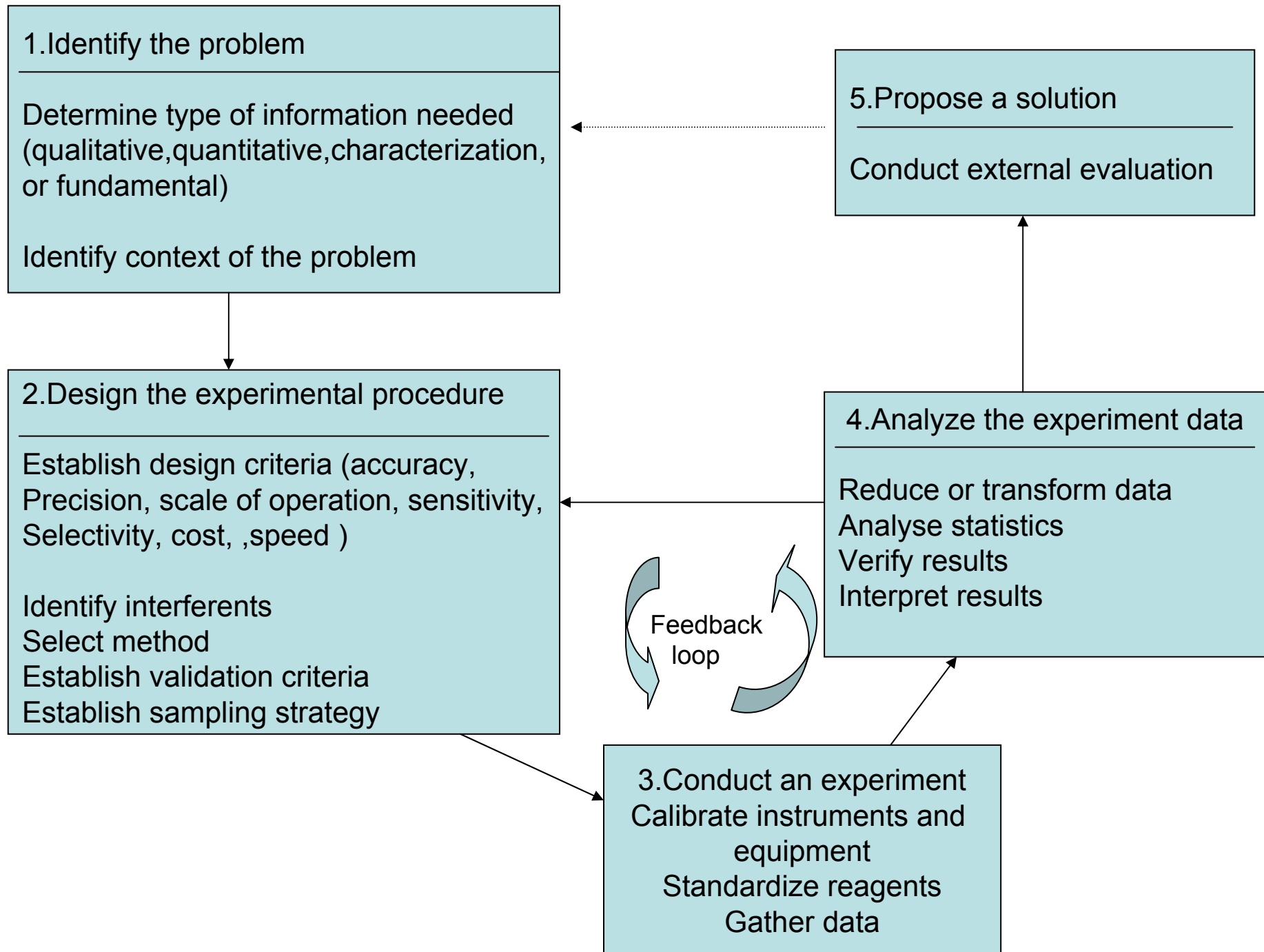

Marching ahead

- Resolving the contradictory evidence of a sportsman taking steroids
- Evaluating the endosulphan exposure to farmers, children and pregnant ladies
- Developing rapid and sensitive detectors for chemical warfare agents.
- Real time modeling and monitoring of an oil spill near a port.
- Developing miniaturized sensors for real time air quality monitoring

Problem solving – Multiple source, interactions

- Accuracy, precision, sensitivity and detection limit
- Amount of sample available, collection, storage, transport and pretreatment of the sample
- Number of samples to be analysed
- Validation of the method, equipment and results
- Report presentation, problem solution and external evaluation
- Cost considerations based on the above

Analytical inputs

- ✓ What exactly is the analytical problem?
- ✓ What type of input information is to be collected?
- ✓ What criteria are to be considered in designing the experiment ?
- ✓ What interferences are expected and how to eliminate the same?
- ✓ How to collect ,store, transport and pretreat the samples
- ✓ Validation of results
- ✓ Can a successful solution is feasible at this stage?

Characteristic Properties

- Emission of radiation
- Absorption of radiation
- Scattering of radiation
- Refraction of radiation
- Diffraction of radiation
- Rotation of radiation

- Electrical potential
- Electrical charge
- Electrical current
- Electrical resistance
- Mass
- Mass-to-charge ratio
- Rate of reaction
- Thermal characteristics

- Radioactivity

Instrumental Methods

- Emission spectroscopy (X-ray, UV, visible, electron, Auger); fluorescence, phosphorescence, and luminescence (X-ray, UV, and visible)
- Spectrophotometry and photometry (X-ray, UV, visible, IR); photoacoustic, spectroscopy; nuclear magnetic resonance and electron spin resonance spectroscopy
- Turbidimetry; nephelometry; Raman spectroscopy
- Refractometry; interferometry
- X-ray and electron diffraction methods
- Polarimetry; optical rotary dispersion; circular Dichroism

- Potentiometry; chronopotentiometry
- Coulometry
- Amperometry; polarography
- Conductometry
- Gravimetry (quartz crystal microbalance)
- Mass spectrometry
- Kinetic methods
- Thermal gravimetry and titrimetry; differential scanning calorimetry; differential thermal analyses; thermal conductometric methods

- Activation and isotope dilution methods

1. ATOM IN HINDU SCRIPTURES

- **Ancient Hindu scriptures recognized that matter is made of tiny discrete particles known as Anu, paramanu, kana.**
- **'Kana' is an aggregate of smaller particles called as 'Anu'. But it is not visible to the naked eye. 'Anu's of each substance are distinctive and capable of independent existence. 'Paramanu' is the smallest discrete particle capable of independent existence but not visible to the naked eye. 'Paramanu' s are essential components of all things we see around us.**
- **The power of the 'paramanu's and 'Anu's was utilized in warfare as 'Astras'(warheads) described as Shakti astra, Brahmastra etc., and in aeroplanes(Vimanas).**

contd...

2 .DALTONS THEORY(1802)

- **Matter is composed of tiny real particles called atoms which are indivisible and cannot be created or destroyed.**
- **Atoms of all substances are identical in nature, weight, size and other properties. Atoms of pure substance differ in weight & other characteristics from other substances.**
- **Atoms combine in definite proportions resulting in chemical compounds.**

contd...

3.FUNDAMENTAL COMPONENTS OF ELEMENTARY PARTICLES

Particle	Notation	Mass* (AMU)	Charge* esu × 10 ¹⁰	Relative charge
Electron	e	0.0005486	-4.8029	-e
Proton	P, 1_1H	1.00757	+4.8029	+e
Neutron	n, 1_0n	1.00893	0	0
Positron	e^+ , B^+	0.0005486	+4.8029	+e
Neutrino	ν	0	0
Antineutrino	0	0
Meson	π	0.156	± 4.8029	± e
	μ	0.118	± 4.8029	± e
Deuteron	d, 2_1D	2.01416	+ 4.8029	+e
Alpha	α , 4_2He	4.00279	+9.6058	+2e

*AMU - Atomic mass unit, equivalent to $1.6603 \times 10^{-24} g$

+esu is the fundamental unit of electrical charges

contd...

4. MODERN ATOMIC THEORY

- An atom consists of a positively charged nucleus of about (10^{-12} cm) and comparatively heavy.
- An extra nuclear arrangement of electrons which is comparatively large $(\cong 10^{-8} \text{ cm})$ and diffuse in character.
- Nucleus consists of a number of protons and neutrons. They are formally related as:

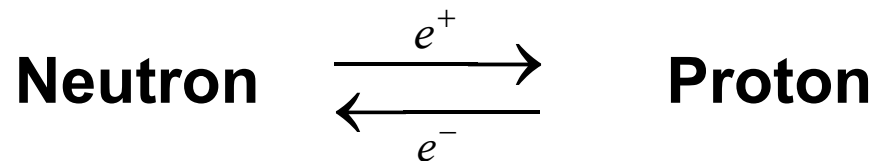

contd...

- Nuclear forces arise from the creation and annihilation of π mesons by nuclear particles (nucleons). During radio active decay processes, changes in nuclear charges occur according to the following mechanisms.



contd...

- **Nuclei with 2,8,20,28,50,82 or 126 neutrons or protons are especially stable. These so called magic numbers represent closed shells of nucleons.**
- **For a given element with Z protons a number of species may exist with the same number of protons but varying in the number of neutrons. Such elements exhibit the same chemical properties but differ in atomic weight and are called isotopes.**
- **Nuclei of same mass number but differing in charge also exist which are called as isobars. But they do differ in their chemical properties. (e.g Ca & Ar)**

contd...

- **Attractive forces exist between neutrons and protons. Energy exchanges occur via mesons among them. The actual neutron to proton ratio is due to the balance between the tendency towards neutron-proton equalisation and proton reduction. All the radio active decay processes are therefore aimed at attaining stable nuclei. This is achieved by :**

- (i) **B-Emission**
 - (ii) **Neutron Emission**
 - (iii) **Positron Emission**
 - (iv) **Orbital Electron Capture**
 - (v) **Proton Emission**
- } For high neutron/proton ratios**
- } For low neutron/proton ratios**

contd...

- **An unstable nucleus (having AMU > 83) arising out of radio active decay or nuclear reaction, readjusts itself to a stable nucleus by the emission of an α particle . In the process mass is lost by 4 AMU ($A \rightarrow A - 4$) and charge is lost by 2 units ($z \rightarrow z - 2$) until it reaches a stable configuration.**
- **Nuclear stability is also attained by the absorption or release of energy. The energetics of nuclear reactions are of course associated with mass changes according to Einstein's equation,**

$$E = mc^2$$

contd...

- **The release of energy takes place either in the form of heat or as radiations. The mass change corresponding to the conversion of hydrogen into helium,**

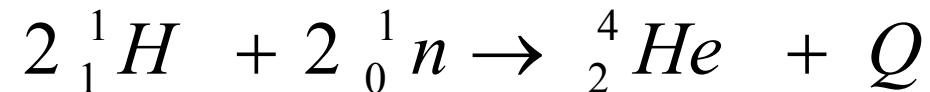

is 0.0302 AMU. This is equivalent to 28.12 Mev of energy per helium atom or 6.45 x 10⁸ k cal per gram atom of helium. This is equivalent to the temperatures prevailing on sun. Hence nuclear reactions are of interest as a source of energy.

contd...

- **There are 5 types of Nuclear reactions:**
 - 1. Capture reactions**
 - 2. Particle- Particle reactions**
 - 3. Fission Reactions**
 - 4. Spallation Reactions**
 - 5. Fusion Reactions**

- **Nuclear reactions can also be classified in terms of bombarding agent. These include:**
 - 1. Alpha induced reactions**
 - 2. Proton induced rations**
 - 3. Deuteron induced reactions**
 - 4. Gamma and X-radiation induced reactions**
 - 5. Neutron induced rations**

contd...

5. THE ELECTRONIC STRUCTURE OF THE ATOMS

- ✓ In 1904 Sir J.J. Thomson proposed the corpuscular theory of matter. He pictured the positive charge of an atom distributed uniformly throughout a sphere of protons and neutrons of about 10^{-8} cm. Negative charge was surrounding it in a jelly-like fashion.
- ✓ Rutherford modified this theory that electrons revolve around the nucleus in such a way that the centrifugal force exactly balances the inward attractive forces much like our planets do around the sun. This view was also not tenable because within the atom, particles having opposite charges are present. Hence regardless of their speed, they enter the nucleus. Moreover the electron losing energy would emit continuous radiation without any sharp breaks.

contd...

- ✓ In 1903, Bohr proposed a radically different view of the atomic structure based on the optical spectrum of Hydrogen. He included the postulates of quantum theory proposed by Max plank.
- ✓ Bohr proposed that the electron in a hydrogen atom always described a fixed circular path around the nucleus. Such orbits named 'stationary states' may be thought of various circles differing in radius. The angular momentum of each stationary states was an integral multiple of $n \cdot h/2\pi$ which amounts to angular momentum. The angular momentum mvr is given by

$$mvr = n(h/2\pi)$$

where n is an integer called a quantum number

contd...

- ✓ He also postulated that as long as the electron remained in a given orbit it neither radiates nor absorbs energy. When the electron moves from one orbit to another it was considered to involve the absorption or emission of definite quantity of energy depending upon whether the electron moved from lower state to higher one or vice versa. This energy manifests as radiation and the frequency of such radiation is manifests a a spectral line which could be related to the energies of electron in the two states E_1 & E_2 as:

$$E_2 - E_1 = h \nu$$

contd...

✓ **Line spectra of hydrogen atom**

Lyman series	n = 2,3,4.....to n = 1
Balmer series	n = 3,4,5.....to n = 2
Paschen series	n = 4,5,6.....to n = 3
Brackett series	n = 5,6,7.....to n = 1
Pfund series	n = 6,7.....to n = 5

- ✓ **Origin of hydrogen spectrum scann pp 83, Morrison**
- ✓ **Bohr's theory could explain the spectra of hydrogen and He^+ , Li^{2+} & Be^{3+} etc. But it failed completely when applied to multiple electron systems. Further it could not account for splitting of optical lines (fine structure) when spectroscopes of high resolving power were employed.**

contd...

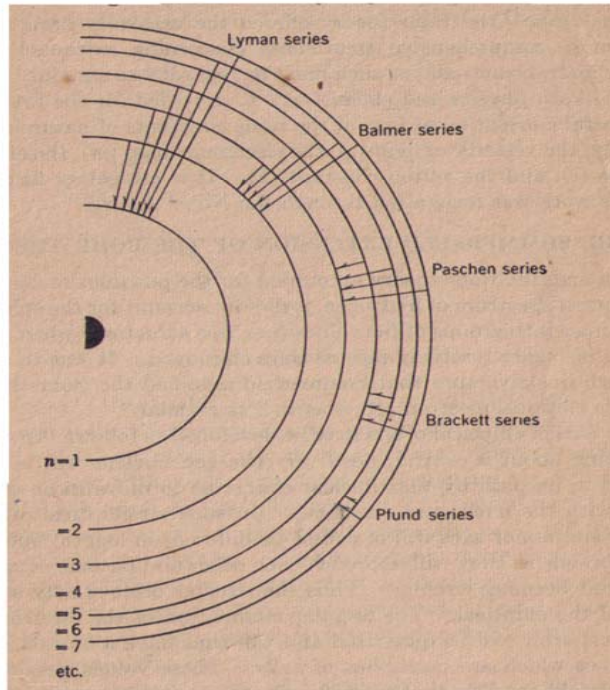

6. SOMMERFELD THEORY

- **In 1916 Sommerfeld modified Bohr's theory to include elliptical orbits which includes circular orbits only as a special case. The velocity of an electron moving in an orbit will be greatest when it approaches closest to the nucleus and least when it is farthest.**

This introduces variability in the orbit also which as a whole will precess around the nucleus. This precessional movement will result in small energy changes and will be reflected as fine structure in the spectrum.

contd...

- **Sommerfeld concept permitted the subdivision of the Bohr's stationary states of slightly differing energy levels corresponding to the differences in orbit shapes.**
- **This is the basis of modern concepts of electronic configurations.**
- **Further it projected the possibility of penetrating orbits. Thus certain electrons may penetrate closer to nucleus than others thus permitting qualitative pictures of the more complicated atoms.**

contd...

7. ELECTRONIC DISTRIBUTIONS IN ATOMS

- # The rule of 8: Inert gas atoms with the exception of Helium contain eight electrons in their outermost arrangement .**
- # Helium, Neon, argon, krypton, xenon and radon contain 2,10,18,36,54 and 86 electrons and represent the end of various horizontal series of periodic classification.**
- # C.R.Bury postulated that maximum number of electrons in the various shells are 2,8,18 and 32. He also stated that no shell can contain more than 8 electrons unless another shell further removed from the nucleus is being formed. This concept permitted logical explanations for the configurations of transition and inner transition elements i.e filling up of inner electronic levels while the outer most ones remained constant.**

contd...

Electronic configurations of inert gas atoms

Symbol	At.No	K	L	M	N	O	P
He	2	2					
Ne	10	2	8				
Ar	18	2	8	8			
Kr	36	2	8	18	8		
Xe	54	2	8	18	18	8	
Rn	86	2	8	18	32	18	8

contd...

8. QUANTUM DESIGNATIONS FOR ELECTRONS

- **The Bohr-Sommerfeld concept of electrons revolving around the atomic nuclei is limited to well defined shapes is essentially a rough pictorial presentation.**
- **Modern concepts based on wave mechanics depict comparative density of the electronic charges at any given point within the atom based on the theory of probability.**
- **Essentially this means electrons will tend to group themselves in a series of positions relative to the nucleus which may be considered as energy levels w.r.t the nucleus. Transitions are permitted only between these energy levels giving rise to spectrum.**

contd...

- **Electrons are best described in terms of four quantum numbers: Principal Quantum number(n) , Orbital quantum number(l), magnetic quantum number(m) and Spin quantum number(s).
The energy levels corresponding to n are given by**

$$w = \frac{-2\pi^2 z^2 e^4 \mu}{h^2} \left(\frac{1}{n^2} \right)$$

where w - energy of the electron

z - Total number of electrons atomic number)

e - Electronic charge

μ - Electronic mass and

h - Planks constant

Crudely this amounts to the mean distance of the electron from the nucleus. Principle quantum number may have value from n=1 to infinity where ∞ refers to the complete removal of the electron & production of a positive ion. They may be designated as K shell, L shell, M shell etc.

contd...

- ✓ **Orbital Quantum number l is a measure of the orbital angular momentum of the electron which is a vector quantity**

$$\frac{h \sqrt{l(l+1)}}{2\pi}$$

The values of l vary from zero to $(n-1)$. Hence for

$n = 1$, l value is 0

$n = 2$ l value is 0,1

$n = 3$, l value is 0,1,2

$n = 4$, l value is 0,1,2,3

Customarily these levels are named after the spectral terms namely $s(l=0)$, $p(l=1)$, $d(l=3)$ and $f(l=4)$ etc and the electrons present in these orbitals are referred as s, p, d and f electrons.

A wave function associated with the orbital motion of an electron is called an orbital. Thus we have s, p, d, f orbitals also.

✓ **Magnetic Quantum number (m_l)**

some spectral lines split if the source is kept in a magnetic field. This is known as Zeeman Effect. The orbital angular momentum vector undergoes a precessional movement and describes a cone about an axis in the direction of the field the magnitude of which is given by $ml(h/2\pi)$.

contd

The magnetic quantum number is an integral value and varies from $-l$ to $+l$. Thus for s electron

s electron $l = 0$ and $m_l = 0$

p electron $l = 1$ and $m_l = -1, 0, +1$

d electron $l = 2$ and $m_l = -2, -1, 0, +1, +2$

f electron $l = 3$ and $m_l = -3, -2, -1, 0, +1, +2, +3$

contd

- **Spin Quantum Number (s)**

An electron also rotates on its own axis. Hence it has its own angular momentum amounting to:

$$\frac{h \sqrt{s (s + 1)}}{2 \pi}$$

where s = 1/2 or -1/2 depending upon whether it is precessing along the applied magnetic field or opposing it. For each value of m_l there are two electrons differing in spin.

- **No two electrons within any atom can have same 4 Quantum numbers. This is known as Pauli exclusion Principle. Each electron differs from every other electron in a given atom in its total energy.**

contd

9. ELECTRONIC CONFIGURATION OF THE ELEMENTS

- ✓ For K shell, $n=1$, $l=0$, $m_l = 0$ and hence it is a single orbital. Only two electrons are permitted with differing spins. The orbital is of S type.
- ✓ Similarly for L shell, 8 electrons are possible according to Pauli exclusion principle. For M, N, O shells 18, 32, 50 electrons can be accommodated.
- ✓ According to the principle of maximum multiplicity when an electron enters a level of fixed n and l values, available orbitals are occupied singly until each orbital is occupied before any pairing occurs.

10. Knowledge of the exact order in which atomic orbitals are occupied is based on the interpretation of atomic spectra in terms of how spectral lines result from permitted electronic transitions. Heavier atoms have complicated atomic spectral patterns and overlaps occurring in the similar systems.

contd

11. Atomic orbitals

Orbitals

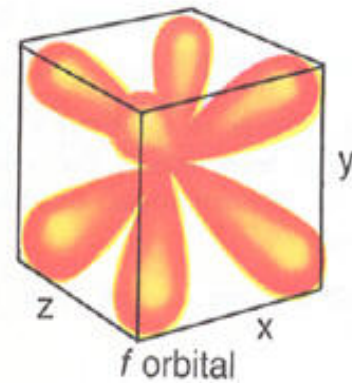
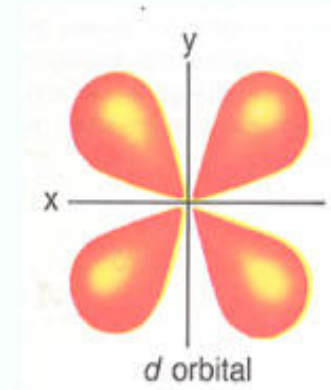
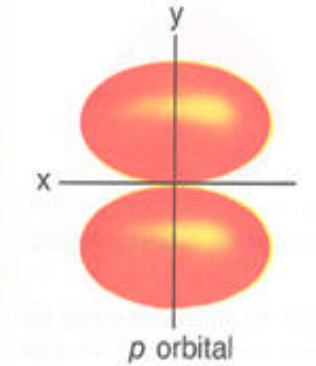
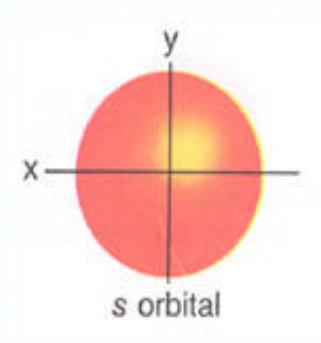

contd

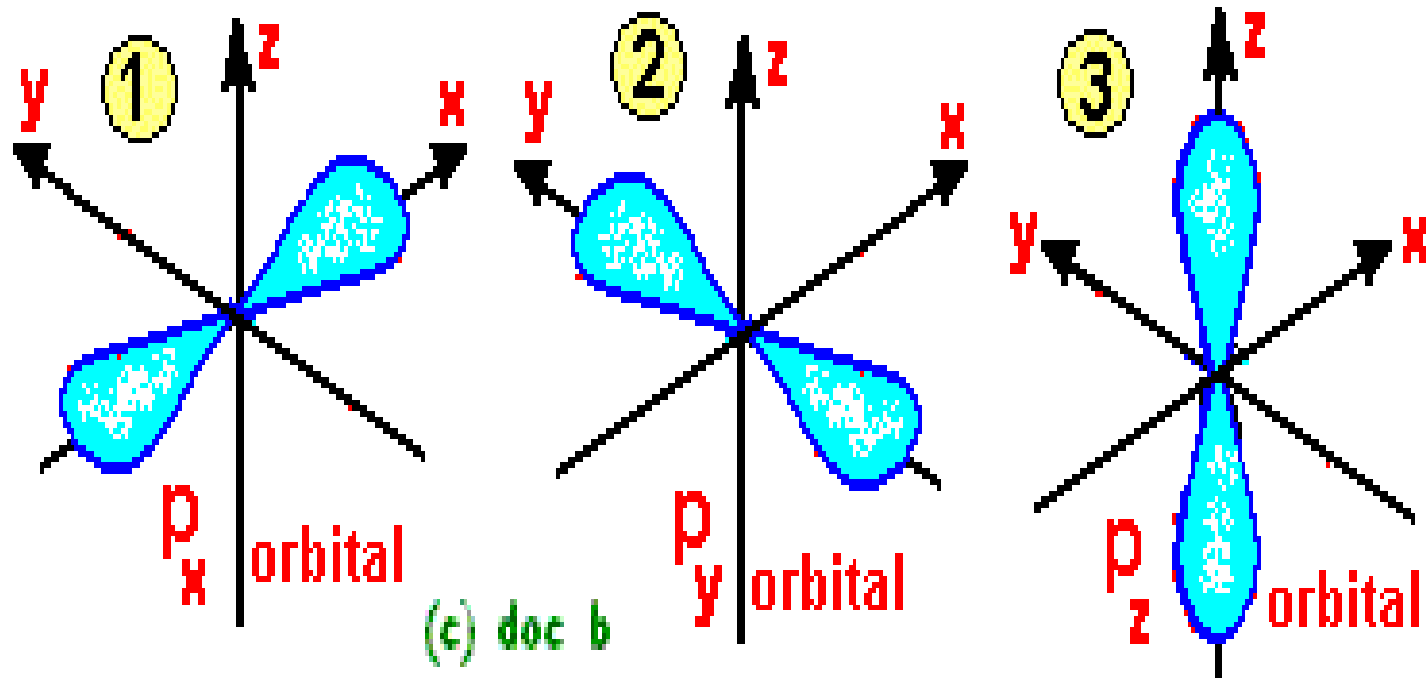

contd

12. Energy Level Diagram

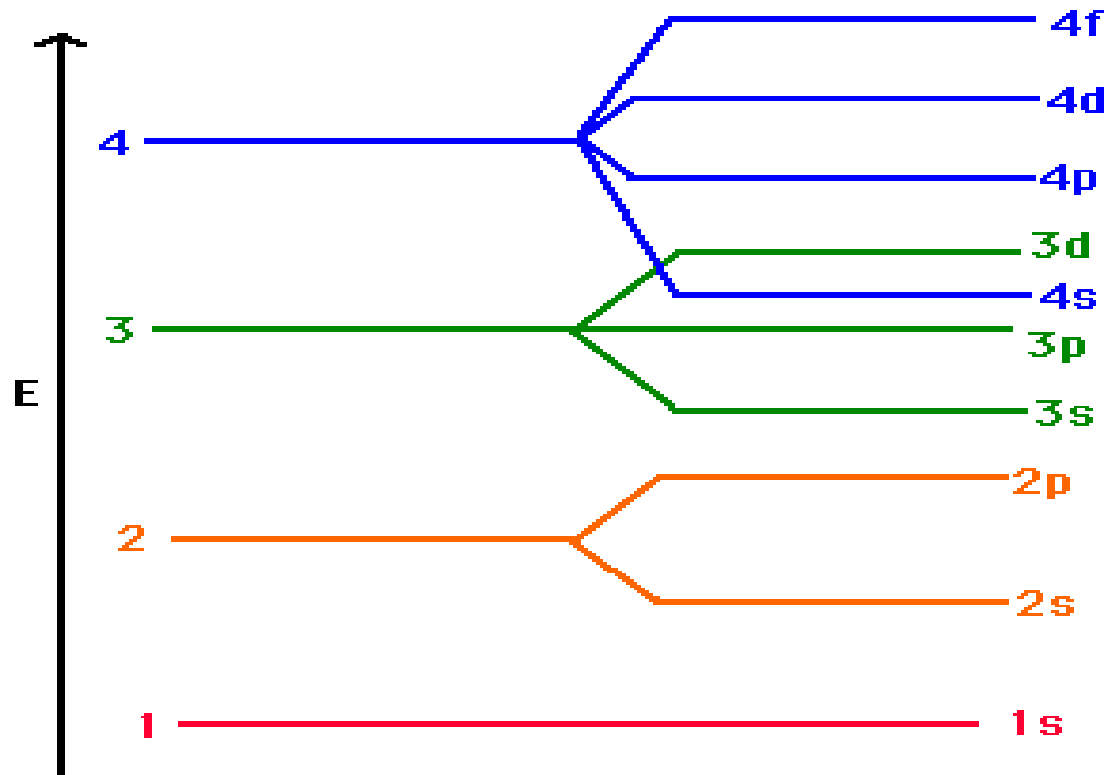

13. Energy level diagram for atomic orbital

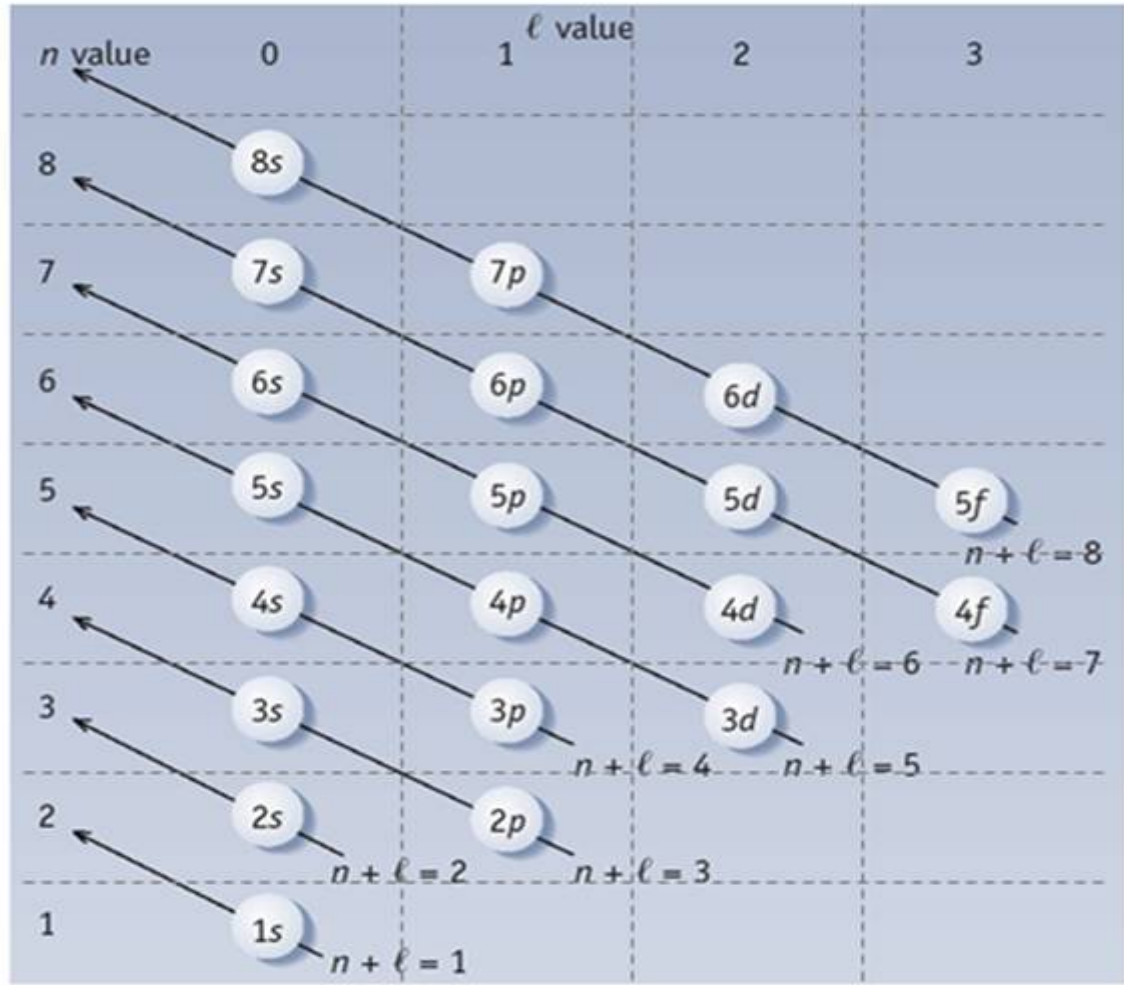

© 2008 Brooks/Cole - Thomson

contd

14. Periodic table

IA 1	IIA 2	IIIB 3	IVB 4	VB 5	VIB 6	VII B 7	VIII 8	VIII 9	VIII 10	IB 11	IIB 12	IIIA 13	IVA 14	VA 15	VIA 16	VIIA 17	VIIA 18																														
H	He											B	C	N	O	F	Ne																														
Li	Be											Al	Si	P	S	Cl	Ar																														
Na	Mg	Sc	Ti	V	Cr	Mn	Fe	Co	Ni	Cu	Zn	Ga	Ge	As	Se	Br	Kr																														
K	Ca	Y	Zr	Nb	Mo	Tc	Ru	Rh	Pd	Ag	Cd	In	Sn	Sb	Te	I	Xe																														
Cs	Sr	La	Hf	Ta	W	Re	Os	Ir	Pt	Au	Hg	Tl	Pb	Bi	Po	At	Rn																														
Rb	Ba																																														
Fr	Ra	Ac	Rf	Db	Sg	Bh	Hs	Mt	Ds																																						
		<table border="1"> <tr> <td>Ce</td><td>Pr</td><td>Nd</td><td>Pm</td><td>Sm</td><td>Eu</td><td>Gd</td><td>Tb</td><td>Dy</td><td>Ho</td><td>Er</td><td>Tm</td><td>Yb</td><td>Lu</td> </tr> <tr> <td>Th</td><td>Pa</td><td>U</td><td>Np</td><td>Pu</td><td>Am</td><td>Cm</td><td>Bk</td><td>Cf</td><td>Es</td><td>Fm</td><td>Md</td><td>No</td><td>Lr</td> </tr> </table>											Ce	Pr	Nd	Pm	Sm	Eu	Gd	Tb	Dy	Ho	Er	Tm	Yb	Lu	Th	Pa	U	Np	Pu	Am	Cm	Bk	Cf	Es	Fm	Md	No	Lr							
Ce	Pr	Nd	Pm	Sm	Eu	Gd	Tb	Dy	Ho	Er	Tm	Yb	Lu																																		
Th	Pa	U	Np	Pu	Am	Cm	Bk	Cf	Es	Fm	Md	No	Lr																																		

Labels in the image:

- alkali metals (IA)
- alkaline earths (IIA)
- transition metals (III B to X)
- post-transition metals (III A to X)
- noble gases (VII A)
- semimetals (metalloids) (diagonal line)
- halogens (VII A)
- lanthanides (f-block)
- actinides (f-block)

S.K. Lower

contd

INTERACTION OF ELECTROMAGNETIC RADIATION WITH MATTER

- ✓ Spectroscopy is the measurement and interpretation of electromagnetic radiation resulting in the absorption, emission, reflection, refraction, diffraction and scattering by atoms, molecules or other chemical species. All these processes are associated with changes in the energy states of the species or modification of its direction or intensity.
- ✓ An electromagnetic radiation may be considered as a wave which carries energy from one location to another at a finite velocity (3×10^{10} cm). As the name suggests an e.m.radiation has two components: electric field and magnetic field which are perpendicular to each other.

POLARIZED ELECTROMAGNETIC WAVE

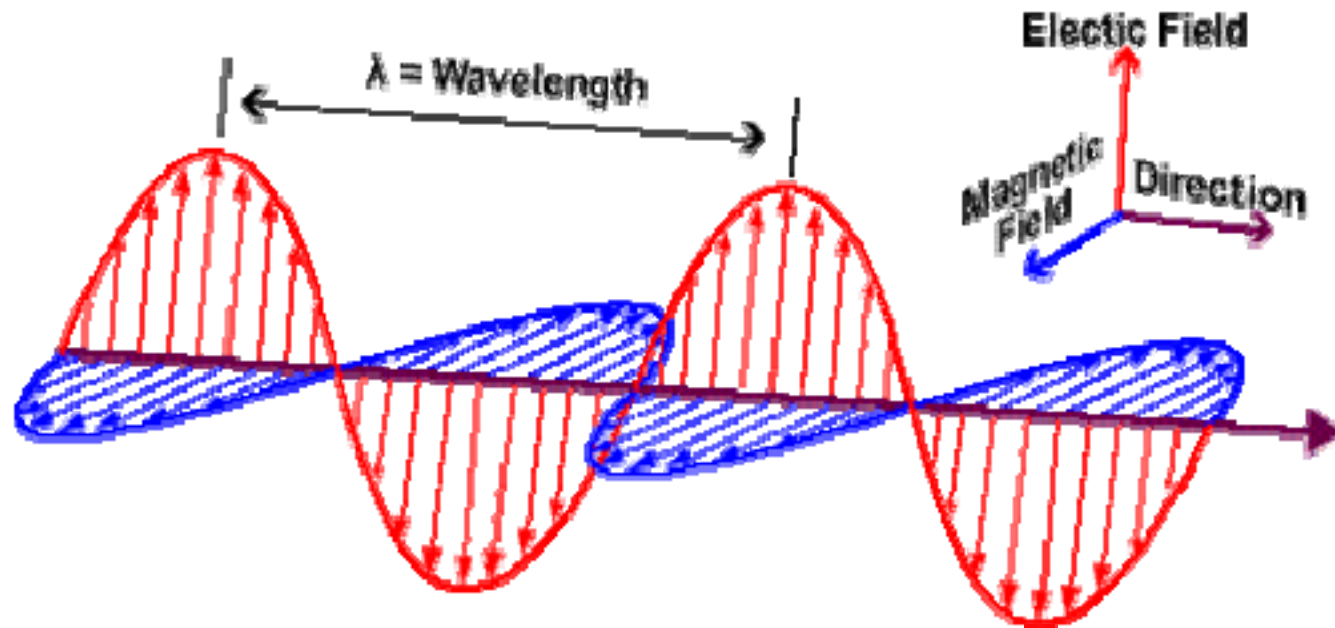

Wave nature of a single frequency electromagnetic radiation

- Many properties of the electromagnetic radiation are conveniently described by considering it as a classical sinusoidal wave model with characteristic wavelength, frequency, velocity and amplitude. E.M radiations pass through vacuum also unlike sound waves.
- However some properties of the electromagnetic radiations (possessing a quantified amount of energy) are both described best as a number of streaming particles traveling in a wave form referred to corpuscles discrete particles) or photons.
- According to Heisenberg's principle it is impossible to measure the wave and particle properties of a photon simultaneously and exactly.
- Therefore it is convenient to imagine photons as particles having specific amount of energy radiating from a source and characterized by an electromagnetic wave

- The wavelength of radiation λ can be visualized as the distance between two maxima of either electrical or magnetic component.
- The frequency ' ν ' is the number of waves that pass any fixed point P per unit time. When a photon passes a particular region of space the electric and magnetic field oscillate with frequency.

Therefore only frequency is truly characteristic of a particular radiation.

- **Mathematically an electromagnetic wave can be described as a sine wave**

$$A = A_0 \sin \theta$$

where A is the amplitude at any point

A₀ is the peak amplitude

θ is the continuous variable

- **Alternately**

$$A = A_0 \sin \omega t$$

Where $\omega t = \theta$, ω is the angular velocity radians/unit time.

A complete cycle occurs when ωt changes from 0-360°. This is called one complete oscillation or one period. Hence the time over which one complete occurs is given by

$$t_{\text{cycle}} = \omega / 2\pi$$

or
$$\nu = \text{frequency} = \frac{1}{t_{\text{cycle}}} = \frac{2\pi}{\omega}$$

- For any wave moving at a constant velocity v , we can write

$$v = \nu \lambda$$

where ν is the frequency in ms^{-1}

ν is in Hertz (cycles per second or s^{-1}) and

λ in meters

- The frequency ν is proportional to the energy E of the photon given by

$$E = h \nu$$

where $h = 6.62 \times 10^{-27}$ ergs when E is expressed in ergs and
 $= 6.63 \times 10^{-34}$ joules. E is expressed as joules.

- Sometimes it is convenient to use “wave number” denoted by $(\bar{\nu})$ to describe the radiation for example in infra red spectrometry. Then the photon energy is expressed as,

$$E = hc \bar{\nu}$$

PROPERTIES OF E.M. RADIATION

Name of the unit	Symbol	Unit for	Used in
Nanometer	Nm	λ	UV, visible, near=infrared
Angstrom+	\AA	λ	X-ray, UV-visible (in older work)
Milimicron+	m μ	λ	Visible (in older work)
Micron, Micrometer	μm	λ	Infrared (common in physics literature)
wavenumber (reciprocal cm)	cm^{-1} ,	ν/c	Infrared, UV- visible (less common)
Electron volt+	eV	E	X-ray, γ -ray
Hertz	Hz	ν	Radiofrequency ,microwave
Cycles per s	Cps	ν	Radiofrequency (less common in current literature)

	nm	Å	cm ⁻¹	eV	MHz	J*
nm		10	10 ⁷	1.240 × 10 ³	2.9979 × 10 ¹¹	1.986 × 10 ⁻¹⁶
Å	.1		10 ⁸	1.240 × 10 ⁴	2.9979 × 10 ¹²	1.986 × 10 ⁻¹⁵
cm ⁻¹	10 ⁷	10 ⁸		1.240 × 10 ⁻⁴	2.9979 × 10 ⁴	1.986 × 10 ⁻²³
eV	1.240 × 10 ³	1.240 × 10 ⁴	8.0655 × 10 ³		2.418 × 10 ⁸	1.602 × 10 ⁻¹⁹
MHz	2.9979 × 10 ¹¹	2.9979 × 10 ¹²	3.3356 × 10 ⁻⁵	4.1355 × 10 ⁻⁹		6.626 × 10 ⁻²⁸
J	1.986 × 10 ⁻¹⁶	1.986 × 10 ⁻¹⁵	5.034 × 10 ²²	6.241 × 10 ¹⁸	1.509 × 10 ²⁷	
Spectrometric region	UV-vis	X-ray UV	Infrared	X-ray γ	Radiofrequency (NMR)	

*4.184 J = 1 cal

	nm	$\overset{0}{A}$	Cm^{-1}	eV	MHz	J^*
nm		10	10^7	1.240×10^3	2.9979×10^{11}	1.986×10^{-16}
$\overset{0}{A}$.1		10^8	1.240×10^4	2.9979×10^{12}	1.986×10^{-15}
Cm^{-1}	10^7	10^8		1.240×10^{-4}	2.9979×10^4	1.986×10^{-23}
eV						
MHz						
J						
Spectrometric region						

- It may be noted that regardless of the units of expression any electromagnetic radiation of frequency ν will have unique wavelength and energy.

The longer the wavelength, the lower is the energy and frequency.

- Energy is closely related to temperature of any object, it can be expressed as

$$E \propto K_B T$$

where K_B = Boltzmann's constant

$$= 1.380 \times 10^{-16} \text{ ergs K}^{-1} \text{ atom}^{-1} \text{ or } 1.380 \times 10^{-23} \text{ joule K}^{-1} \text{ atom}^{-1}$$

If we consider energy per mole of the material

$$E \propto R T$$

where R = the gas constant

$$= 8.3145 \times 10^7 \text{ erg K}^{-1} \text{ mol}^{-1} \text{ or } 8.3145 \text{ joule K}^{-1} \text{ mol}^{-1}$$

- The energy of the photons should not be confused with brightness or intensity of the source. But it relates to the colour of the light.
- The power of a light source is given by

$$P = \text{number of photons} \times \text{photon energy}$$

It is the energy of a beam of radiation that reaches a given area per second.

- Intensity (I) of a source of radiation is the power emanating per unit solid angle.

ELECTROMAGNETIC SPECTRUM

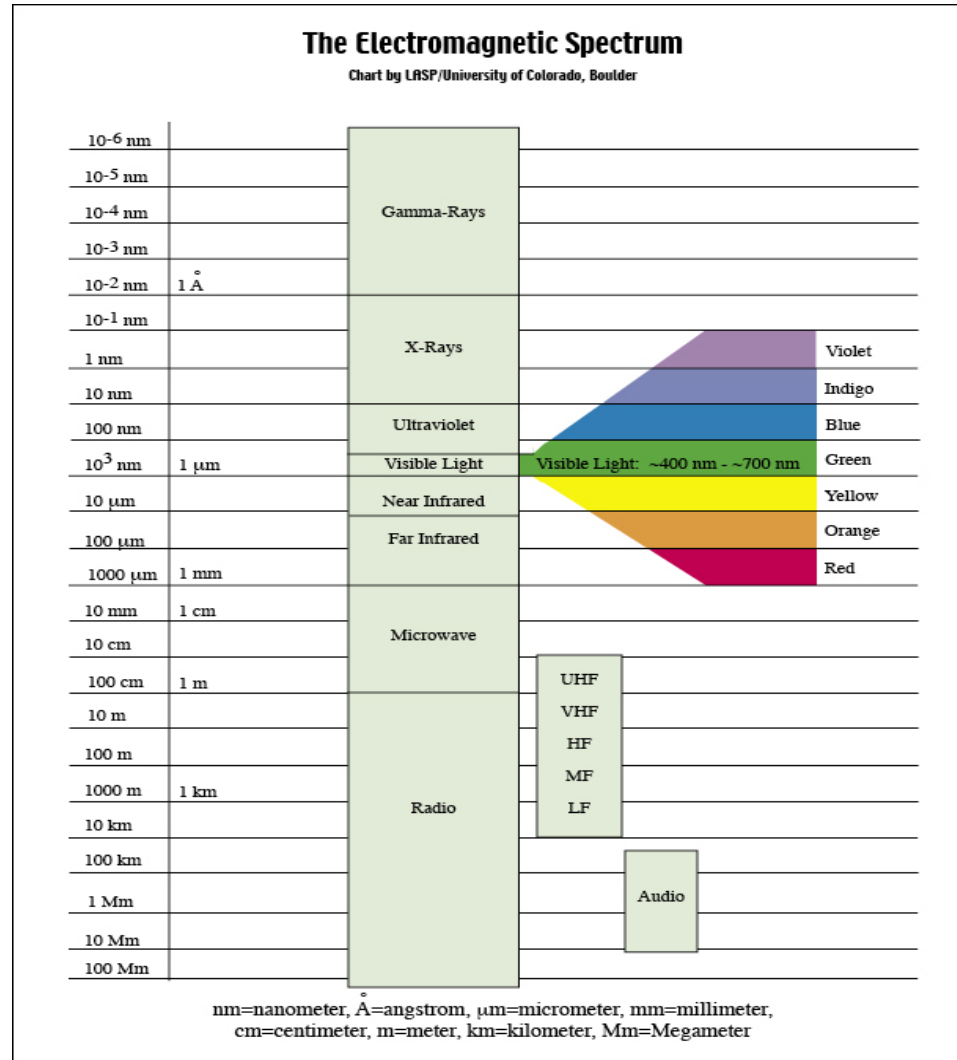

TRANSMISSION OF RADIATION

- **The rate of propagation of electromagnetic radiation through a transparent material (such as atoms, ions, molecules, particles) is less than that of vacuum. However frequency change will not be observed which means that permanent energy transfer to the medium does not occur.**
- **Therefore the interaction involved must be only temporary deformation of the electronic clouds associated with the atoms and molecules (10^{-14} to 10^{-15} s). Since the velocity of radiation in the media is wavelength dependent the refractive index of the media also must change. The variation of R.I with wavelength is called 'dispersion'.**

- **Dispersion is a complex phenomena. Dispersion curves usually show two regions. Normal dispersion in which there is a gradual increase in refractive index with increasing frequency. Anomalous dispersion occurs at frequencies in which sharp changes occur coinciding with natural harmonic frequency of some part of a molecule, atom or ion leading to the absorption of the beam.**
- **In spectroscopy, dispersion curves are important for optical components such as lenses. Most suitable components for the manufacture of lenses are those in which refractive index should be high and constant. This results in reduced chromatic aberrations.**

For the fabrication of prisms refractive index should be large but also highly frequency dependent.

REFLECTION OF RADIATION

- **Mirrors reflect the radiation falling on them. Without any loss of the incident radiant power. Hence they are used as optical components of a spectrum. Concave mirrors reflect the radiation as well as concentrate the reflected radiation at its focal point.**
- **When radiation crosses an interface between media differing in refractive index reflection always occurs. For a beam entering an interface at rt.angles the fraction reflected is given by**

$$\frac{I_r}{I_o} = \frac{(n_2 - n_1)^2}{(n_2 + n_1)^2}$$

where I_o intensity of the incident beam and

I_r is the reflected intensity,

n_1 & n_2 are the refractive indexes of the two media.

REFRACTION PHENOMENA

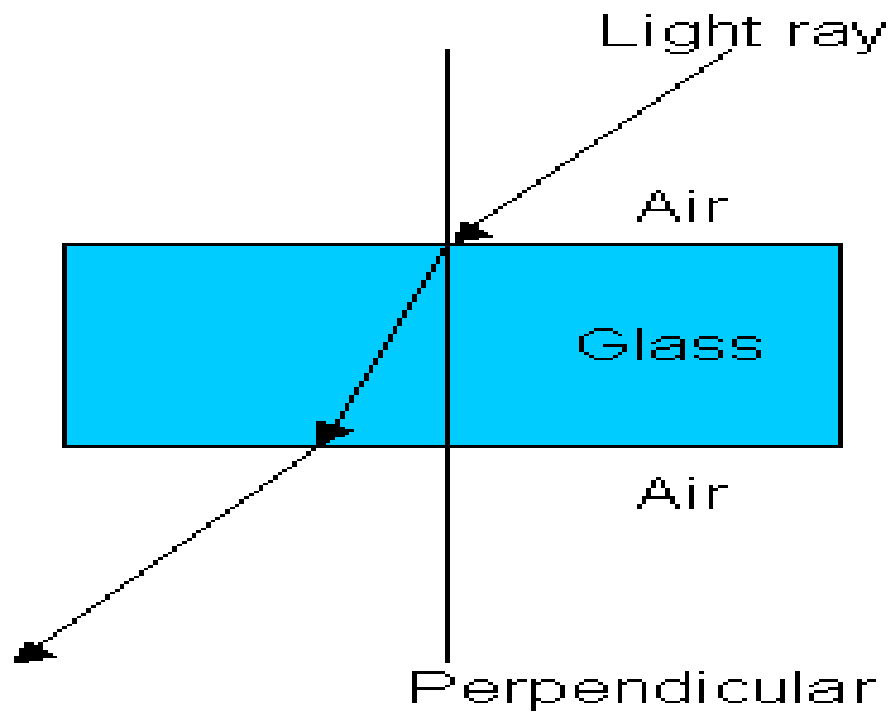

- When radiation passes at an angle through the interface between two media having differing densities an abrupt change in the direction occurs. This is called as refraction owing to the changes in the velocity of the radiation in the two media.

The extent of refraction is given by Snells law

$$\frac{\sin \theta_1}{\sin \theta_2} = \frac{n_2}{n_1} = \frac{V_2}{V_1}$$

In vaccum $V_1 = c$ and n_1 is unity. Hence

$$(n_2)_{vac} = \frac{(\sin \theta_1)_{vac}}{\sin \theta_2}$$

Refractive indices of materials are measured with air as one medium and available in data bases.

SCATTERING OF RADIATION

- **Momentary absorption of radiant energy by atoms, ions, or molecules followed by reemission of the radiation in all directions is known as scattering. Particles having comparable dimensions to that of the incident radiation removes most of the reemitted radiation by destructive interference except those traveling in the original direction. A very small fraction of the radiation is transmitted at all angles from the original path & its intensity increases with particle size.**
- **Scattering by molecules or aggregates having smaller dimensions than the incident radiation is called Rayleigh scattering.**
- **Larger molecules scatter radiations in different quantities in different direction. This is called as Mie Scattering.**
- **When the scattered radiation is quantized like those occurring in vibrational energy level transitions in molecules as a consequence of polarization process, it is called as Raman Scattering.**

POLARIZATION OF RADIATION

- Ordinary radiation consists of a bundle of electro magnetic waves in which vibrations are equally distributed among a huge number of planes centered along the path of the beam.
- Viewed end on it looks like an infinite set of electric vectors fluctuating from zero to a maximum amplitude A .
- The vector in any one plane say XY can be resolved into two mutually perpendicular components. Removal of one of the two resolved planes of vibration produces a plane polarized beam. It occupies a single plane. Radio waves emanating from an antenna and micro waves produced by a Klystron tube are plane polarized.
- Polarized ultraviolet and visible radiation is produced by passing the e.m beam through a media that selectively absorbs, reflects or refracts that vibrates in only one plane.

POLARIZATION OF LIGHT WAVES

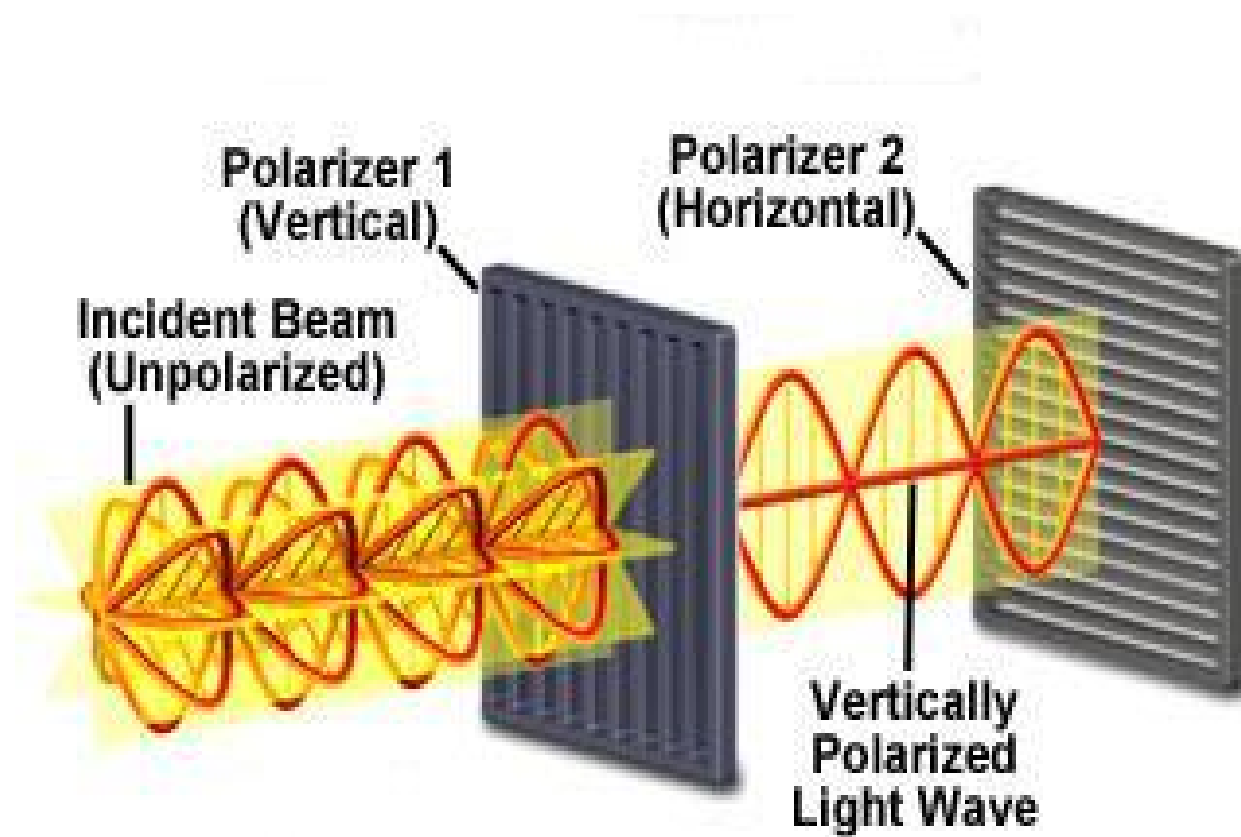

DISPERSION OF E.M RADIATION

- Dispersion is a complex phenomena. Dispersion curves usually show two regions:

Normal dispersion in which there is a gradual increase in refractive index with increasing frequency.

Anomalous dispersion occurs coinciding with natural harmonic frequency of some part of a molecule, atom or ion leading to the absorption of the beam.

- In spectroscopy dispersion curves are important for optical components such as lenses. Most suitable components for the manufacture of lenses are those in which refractive index should be high and constant. This results in reduced chromatic aberrations.

For the fabrication of prisms refractive index should be large but also highly frequency dependent.

DISPERSION CURVE

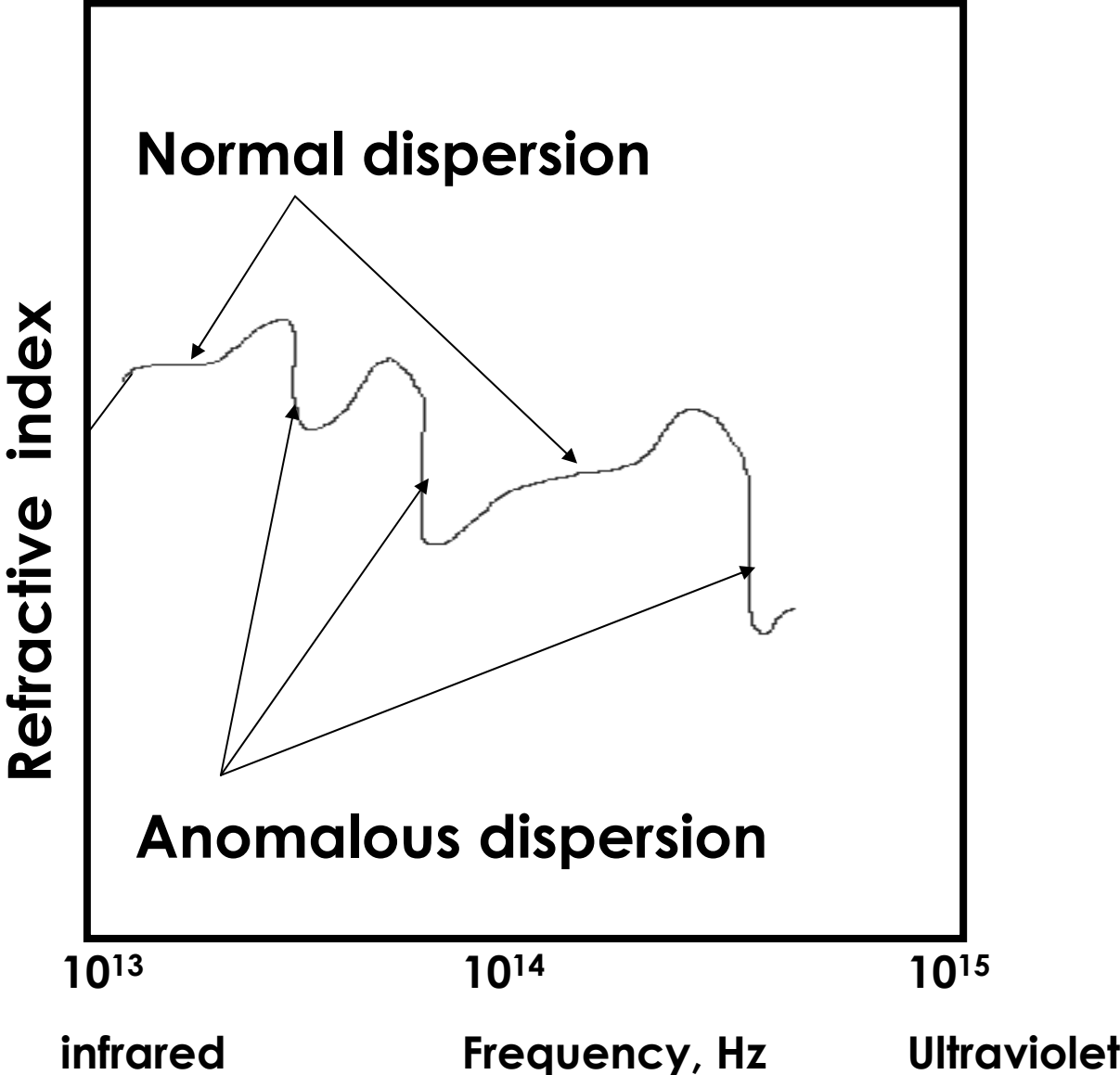

DIFFRACTION OF RADIATION

- **Diffraction refers to the bending of a parallel beam of electromagnetic radiation as it passes through a sharp barrier or a narrow opening. It is a consequence of interference which can be easily demonstrated in the laboratory.**
- **When a parallel beam of light is allowed to pass through a pin hole, two closely spaced pin holes are seen on a screen placed across it.**
- **If the radiation is monochromatic a series of dark and light image appear perpendicular to the plane of the radiation.**

PIN HOLE DIFFRACTION

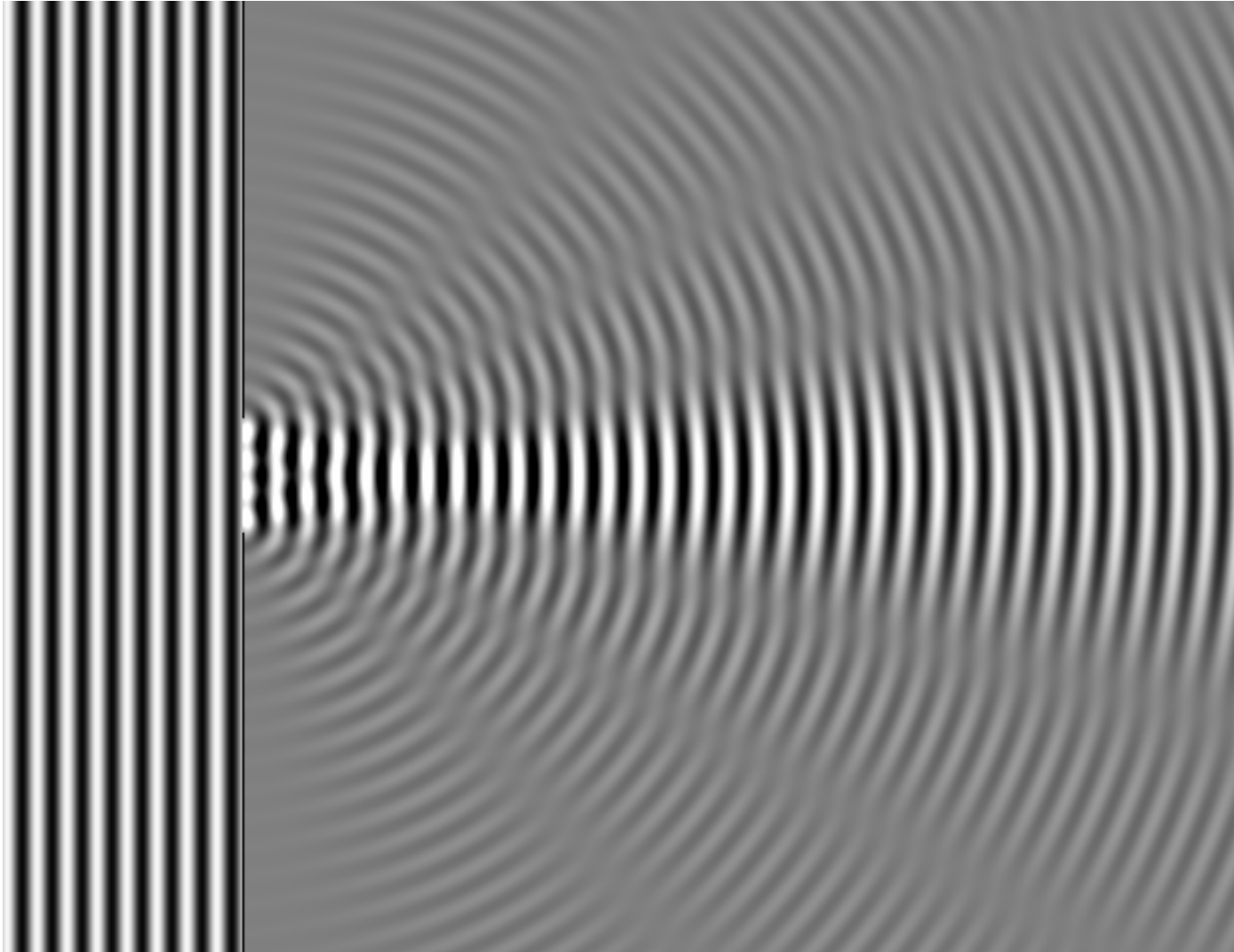

➤ In the above figure it can be shown that

$$\overline{CF} = \overline{BC} \sin \theta$$

For two beams to be in phase at D, it is necessary that \overline{CF} should correspond to the wavelength of the radiation. Hence

$$\lambda = \overline{CF} = \overline{BC} \sin \theta$$

Since reinforcement also occurs at 2λ , 3λ etc. Hence,

$$n\lambda = \overline{BC} \sin \theta$$

where n is an integer called the order of the interference.

- **When the phase differences remain entirely constant with time the system is said to be coherent. Then only a regular diffraction pattern is observed.**

The spacing of the bands depends on the distance between the slits ' d ' and the following relation holds:

$$n\lambda = d \sin \theta$$

- **If two different wavelengths of red & blue are used, the two colors will be separated on the screen. If white light is used a number of small rainbows containing all the colors will appear.**
- **By placing a moving slit across the screen any color or wavelength can be selected. This principle is used in gratings. We will study more about gratings and their uses in spectrophotometry .**

PRISMS AS A DISPERSIVE DEVICES

- ✓ A prism disperses the incident radiation depending on its refractive index and its variation with wavelength. A prism can be used to disperse ultraviolet, visible and infrared radiation. The material of construction depends on the wavelength region.

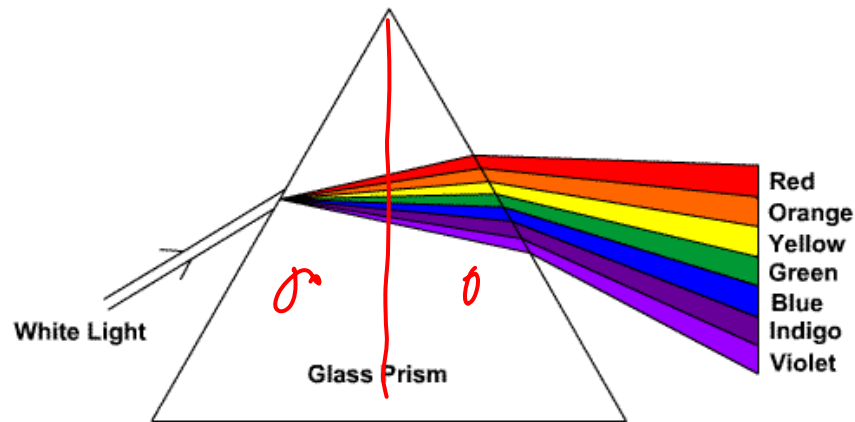

60° PRISM

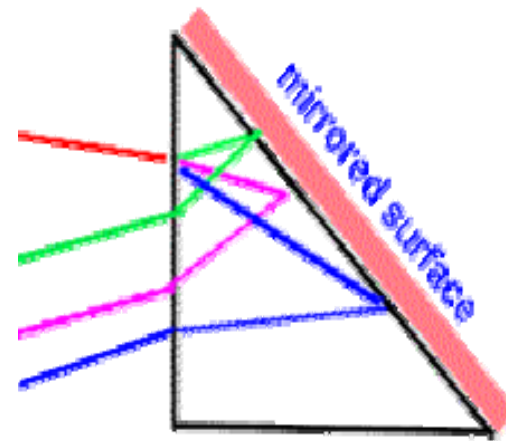

30° PRISM

- ✓ **A prism can be constructed by fusing together two 30° prisms. This is called as Cornu type. Another arrangement is to use a 30° prism with a mirrored back. In Cornu mounting the dispersed radiation is collected across the prism and in Littrow mounting it is collected on the same side. Here refraction takes place twice on the same side with less material coupled with saving of space.**

MONOCHROMATOR SLITS

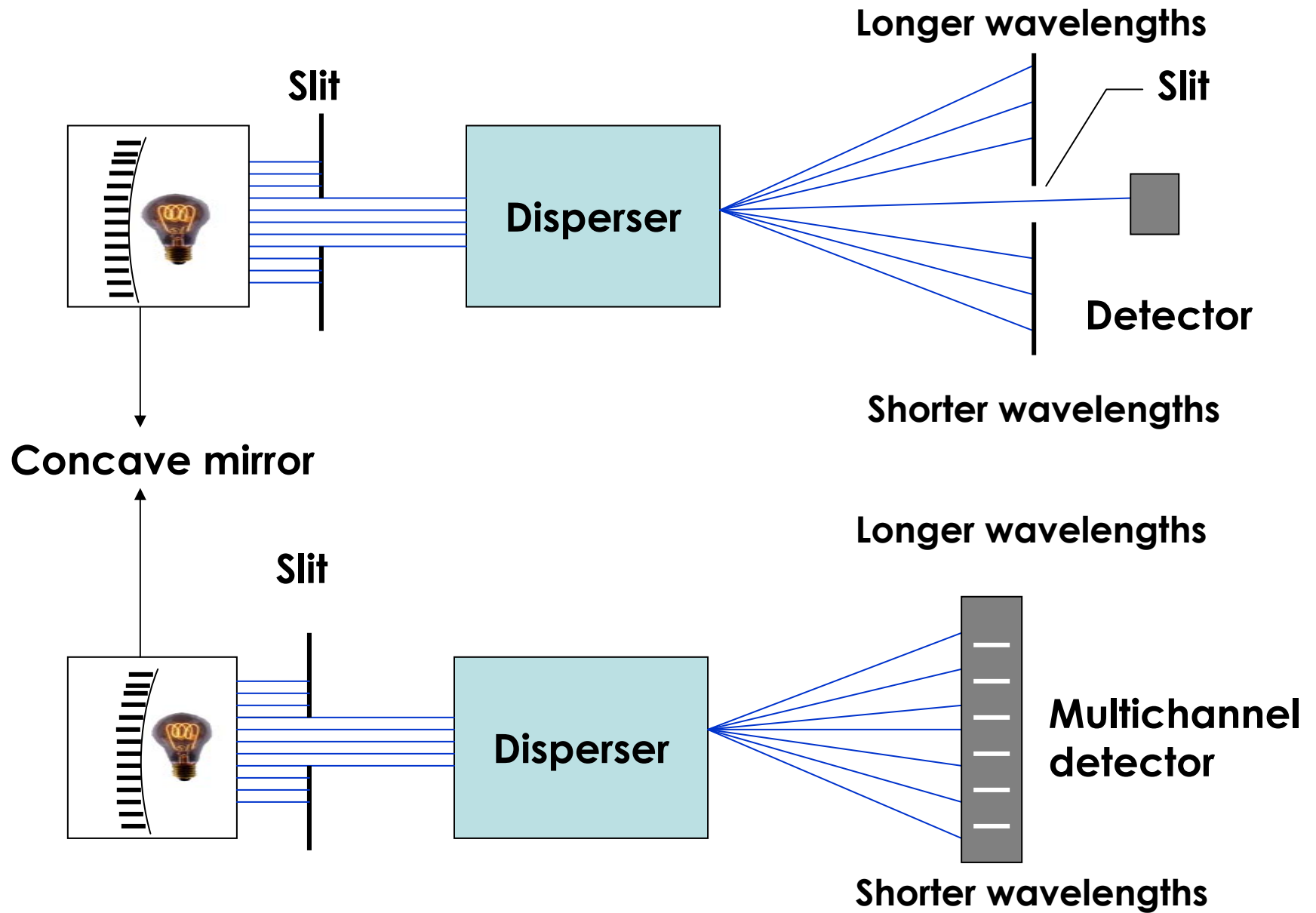

MONOCHROMATOR SLITS

- ✓ The slits of a monochromator play an important role in determining its performance characteristics and quality. Usually two slits are employed: one as the entrance slit which serves as the light source and another as the exit slit on which the image of the entrance slit is formed.
- ✓ If the radiation source consists of a discrete wavelengths a series of rectangular images appears on the exit plane which appear as bright lines corresponding to differing wavelengths. Movement of the monochromator setting in one direction or the other produces a continuous decrease in emitted intensity when the entrance slit image has moved a distance equal to its full width.

MONOCHROMATOR SLITS

- ✓ Illumination of the exit slit with the desired wavelength is invariably associated with some unwanted radiation as shown here (λ_1 & λ_2). This is known as “ bandwidth ”.

Monochromator setting

λ_1 λ_2 λ_3

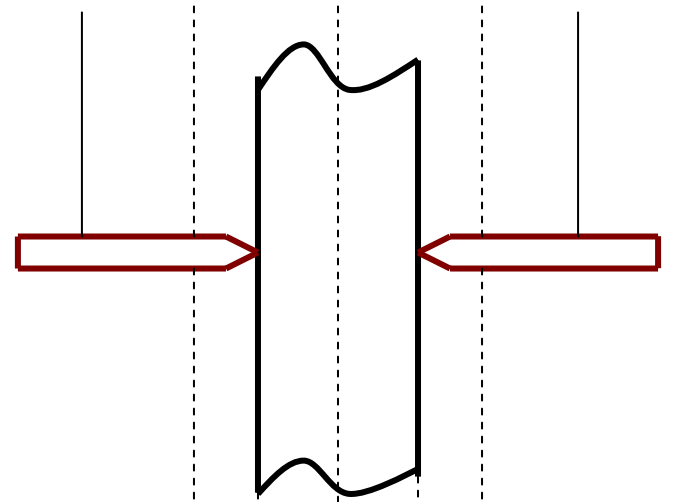

Exit slit

Effective bandwidth

Radiant power P

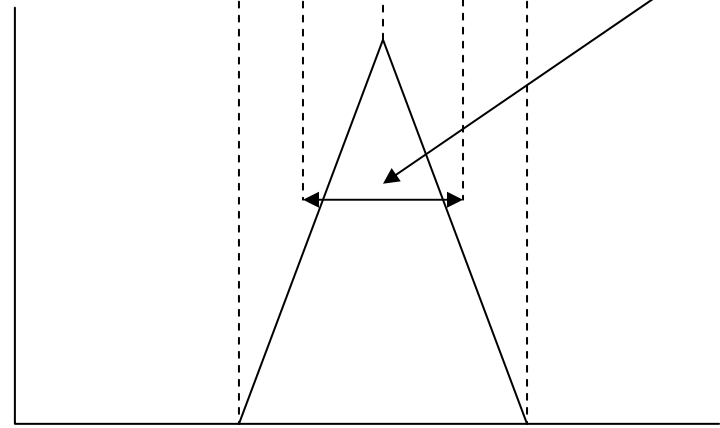

λ_1 λ_2 λ_3

Bandwidth monochromator setting, λ

- ✓ **The effective bandwidth also called as spectral band pass or spectral slit width is “ half of the bandwidth ” when the two slit widths are identical.**
- ✓ **When the effective bandwidth is decreased to one half the wavelength of the three beams complete resolution can be achieved.**

THE PHOTOELECTRIC EFFECT.....

- **The photoelectric effect(1887) was discovered by Heinrich Hertz who reported that a spark jumped more readily between two charged spheres when their surfaces were illuminated with light.**
- **Einstein offered a simple and elegant explanation for the photoelectric effect in 1905, but experimental confirmation came only in 1916 with Millikan's systematic studies.**

SCHEMATIC DIAGRAM OF PHOTOELECTRIC EFFECT

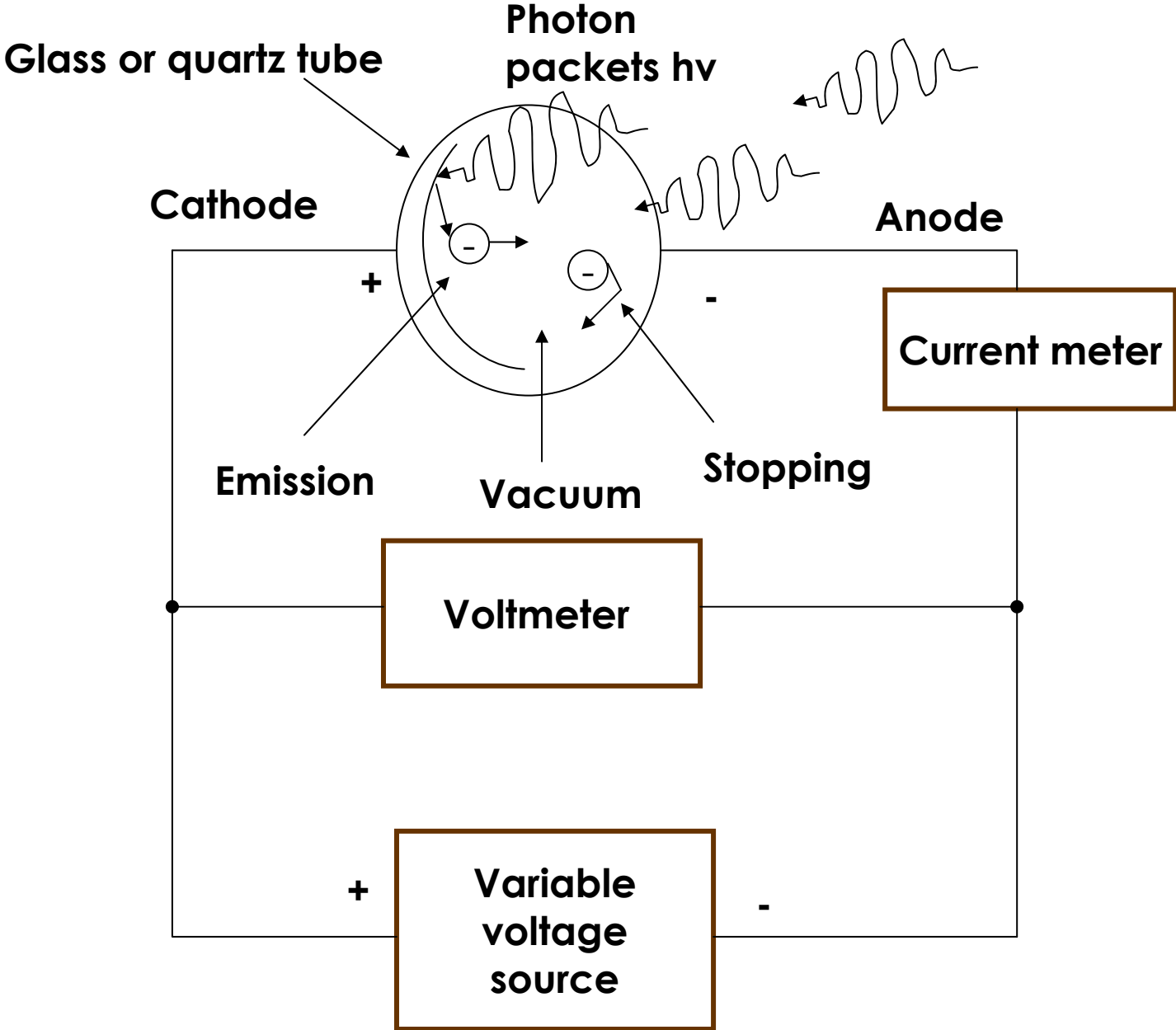

- When monochromatic light falls on a photocathode (A cathode coated with alkali metals), electrons of varying kinetic energies are emitted from its surface and fly over to anode in the phototube as long as the voltage V applied between the anode and cathode is positive, producing a current I in the circuit.
- When the voltage across the phototube is adjusted such that the anode is negative, the photoelectrons are repelled by the anode and photocurrent decreases.
- The photoelectric current measured as a function of the applied voltage V_0 at which photoelectric current reaches zero multiplied by the electronic charge (1.60×10^{-19} Coulombs) gives the kinetic energy of the most energetic electrons in joules.
- When maximum kinetic energy for various coatings are plotted as a function of the radiation frequency, we get a straight line response with a slope of h (Planks constant = 6.6254×10^{-34} joule second) with an intercept w which is known as work function.

- The plots can be described by the equation,

$$KE_m = h\nu - w \text{ or } E = KE_m + w = hc / \lambda$$

- The work function **-w** is characteristic of the surface material and represents the minimum energy of binding the electron to the metal atom. It is also equal to the energy of the electromagnetic radiation (photon energy) required to eject the photo electron from the irradiated surface.
- Therefore it can be concluded that no electron can be ejected until the sum of the work function KE_m is realized. Therefore the energy is not uniformly distributed over the beam front but concentrated in packets or bundles of energy, which is a thumping confirmation of the Quantum mechanical theory.
- This equation permits the calculation of the energy of any electromagnetic radiation of known frequency or wavelength and vice versa.

Example 1

Calculate the energy of the 5.5\AA X-ray photon.

Solution:

we write $E = h\nu = hc / \lambda$

Substituting the values we get,

$$E = \frac{(6.63 \times 10^{-34} \text{ J}\cdot\text{s}) \times (3.00 \times 10^8 \text{ m/s})}{(5.5 \text{ \AA})(10^{-10} \text{ m/\AA})}$$

$$= 3.6163 \times 10^{-16} \times 6.24 \times 10^8 \text{ eV/J}$$

$$= 2.26 \times 10^3 \text{ eV}$$

Example 2

Calculate the energy of the 430nm photon of visible radiation

Solution:

$$E = \frac{(6.63 \times 10^{-34} \text{ J}\cdot\text{s}) (3 \times 10^8 \text{ m/s})}{430 \text{ nm} \times 10^{-9} (\text{m/nm})}$$

$$= 4.6255 \times 10^{-19}$$

Energy of the radiation is usually expressed in KJ/mole

$$E = 4.6255 \times 10^{-19} \text{ J/photon} \times \frac{6.02 \times 10^{23} \text{ photons}}{\text{mol}} \times 10^{-3} \frac{\text{KJ}}{\text{J}}$$

$$= 278.4551 \text{ KJ/mol}$$

THE PHOTOELECTRIC EFFECT.....

Thus the quantum theory originally proposed for black body radiation was extended to explain the emission and absorption processes. The essential postulates of quantum theory are:

1. The ions, atoms and molecules exist only in certain discrete energy states. When it changes its state it absorbs or emits an amount of energy exactly equal to the energy difference between the states.
2. During transition from energy state to another, the frequency ν or the wavelength λ of the radiation emitted or absorbed is related the energy difference between the states by the equation

$$E_1 - E_2 = h\nu = hc / \lambda$$

where E_1 is the energy of the higher state and E_2 is the energy of the lower state.

THE PHOTOELECTRIC EFFECT.....

- For atoms or ions in the elemental state, the energy of any state arises from the movement of the electrons around the nucleus. Such energy levels are called electronic energy levels.
- Molecules in addition to the electronic states exhibit quantized vibrational and rotational states arising from the rotation of molecules or functional groups of molecules around their centre of mass.
- The lowest energy state of an atom or molecule exists at room temperature. It is called ' ground state '. Higher energy states are termed as excited states.
- Detectors used in spectrophotometers, I.R, fluorescence, HPLC etc., work on the principle of photoelectric effect. These include barrier layer photovoltaic cells, vacuum phototubes, photo multiplier tubes, diode array detectors etc.

NATURE OF INTERACTION OF RADIATION AND MATTER

- **A sample can be subjected to a chemical stimuli in the form of heat, electrical energy or light, bombardment, or a chemical reaction.**
- **The stimulus causes the analyte species to move from one energy state to another energy state. In the process energy is absorbed or emitted or scattered. Information about the analyte can be obtained by measuring the electromagnetic radiation.**

EMISSION PROCESS

Emitted radiation P_E

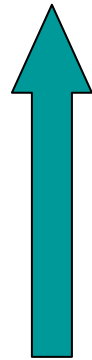
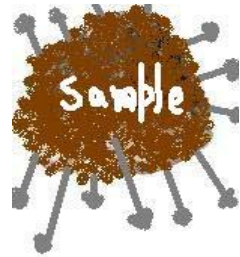

Thermal, electrical, or
chemical energy

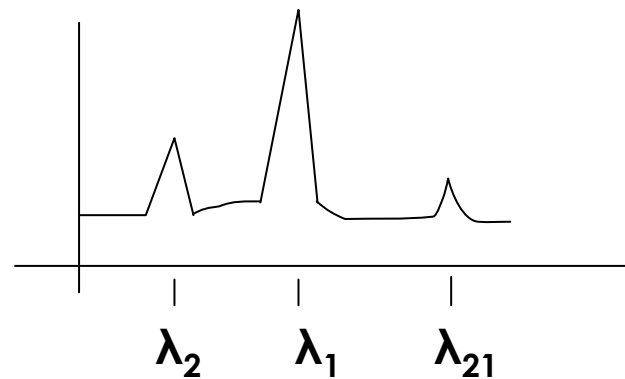
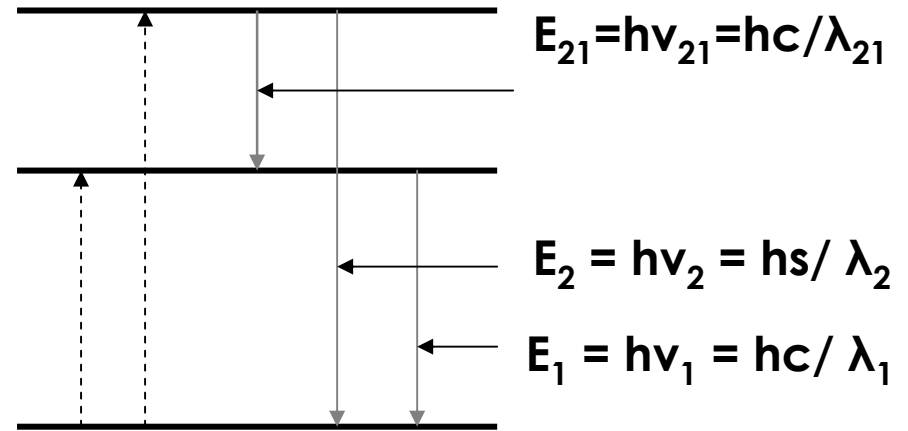

ABSORPTION PROCESS

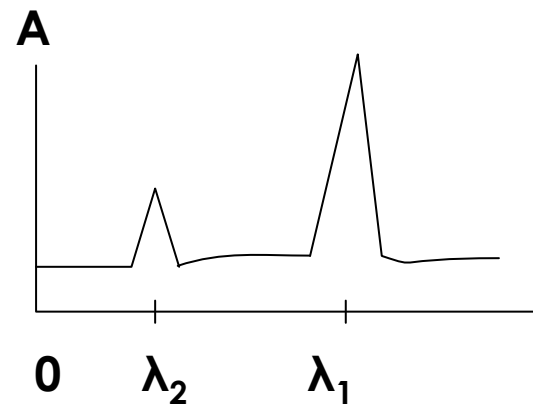
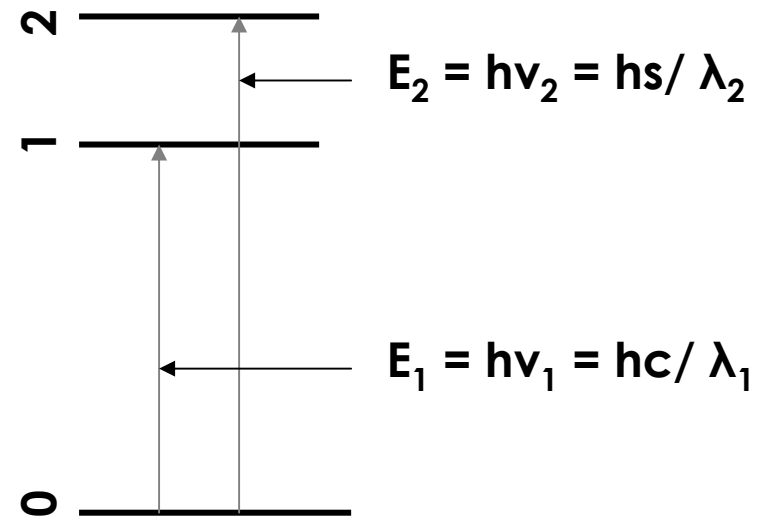
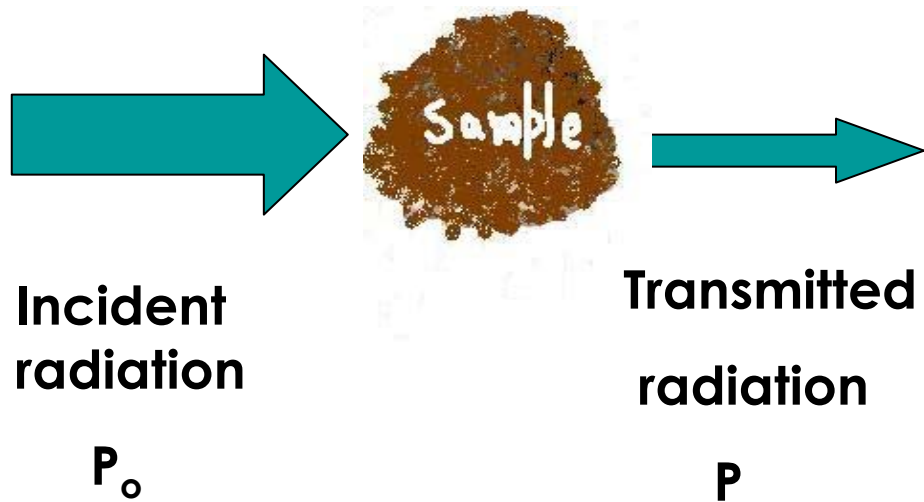

EMISSION OF RADIATION

- **When excited atoms, ions or molecules return to ground state the excess energy is released as heat or in the form of photons. The excitation can be brought about by:**
 - i) Bombardment with electrons or other elementary particles. This gives rise to X-radiation.**
 - ii) Electric current , ac spark or heat source such as dc arc, or furnace. This gives rise to ultraviolet, visible or infra red radiation.**
 - iii) Beam of electromagnetic radiation. This produces fluorescence.**
 - iv) Exothermic chemical reaction which produces chemiluminescence.**

TYPES OF SPECTRA

- **The atomic and molecular spectra are usually plotted as the function of the relative power of the emitted radiation with respect to the wavelength or frequency. A typical spectra will have three components: lines, bands and a continuum.**
- **Line spectra are a series of well defined peaks. Band spectrum consists of a several groups of closely spaced but not well resolved peaks. The continuum part of the spectrum does not show any peaks but line and band spectra are super imposed in the spectrum.**

LINE SPECTRA

- **Line spectrum of atomic particles are preferably obtained in the gas phase. Typical widths of the peaks are about 10^{-5} nm (10^{-4} Å).**
- **X-ray line spectra are produced by the transitions of electrons to inner most orbitals. Therefore it is a characteristic of the element but not of the compound.**

BAND SPECTRA

- **Radicals and small molecules usually exhibit band spectra. The peaks are associated with vibrational energy levels. The life time[̄] of vibrational energy state is 10^{-15} sec compared with that of an electronic state (10^{-8} sec).**
- **Therefore transition always occurs from the lowest vibrational energy of the excited state to any of the vibrational energy level of the ground state. The loss of energy from vibrational levels to the lowest vibrational energy occurs through the collision with other molecules.**

CONTINUUM SPECTRA

- **Radiation from the black body when heated to incandescence produces continuum spectrum.**
- **The energy peaks shift to shorter wavelengths with increasing temperature. Heated solids are important sources of uv, visible and infrared radiations.**

ABSORPTION OF SPECTRUM

- **Absorption of electromagnetic energy by the atoms, ions and molecules promotes them to higher energy excited states according to the laws of quantum mechanics. The energy difference corresponding to each excitation is unique for each species thus permitting the characterization of the sample. This is usually accomplished by plotting absorbance as a function of wavelength or frequency.**
- **Absorption spectra differ widely in appearance from sharp peaks to smooth continuous curves depending on the physical state, complexity of the molecule and the environment of the sample (matrix).**
- **Atomic spectra of an element results in only a few simple and as excitation can occur only at electronic energy levels of the outermost or bonding electrons only.**
- **Molecular absorption spectra are usually more complex involving quantized vibrational and rotational energy states. The energy of vibrational transition is much more than that of rotational transitions.**

- **Molecular absorption peaks involving electronic energy fairly broad owing to the presence of a number of vibrational and rotational energy levels associated with them. As a result the spectrum of a compound consists of a number of closely spaced absorption lines that constitute a broad smooth absorption band giving the impression of a continuous spectrum.**
- **Absorption of pure vibrational energy is the basis of infrared spectroscopy.**
- **Pure rotational absorption spectra are observed in the micro wave region.**

- **Electronic spectral transitions in ions and molecules gives rise to spectrophotometry. The wavelength of the energy source does not change here. Only the change in the intensity of the incident beam and transmitted radiation are measured.**
- **Sometimes the absorbed energy of a molecule is reemitted as a radiation of lower frequency or longer wavelength. This results in fluorescence phenomenon.**
- **Energy changes occurring in the electrons and nuclei under a strong magnetic field are best studied by nuclear magnetic resonance or electron spin resonance.**