

Module 4 – (L12 - L18): “Watershed Modeling”
Standard modeling approaches and classifications, system concept for watershed modeling, overall description of different hydrologic processes, modeling of rainfall, runoff process, subsurface flows and groundwater flow

WATERSHED MANAGEMENT

Prof. T. I. Eldho

Department of Civil Engineering,
IIT Bombay

Lecture No - **14** **Hydrologic Processes**

L14– Hydrologic Processes

- **Topics Covered**
- Hydrologic cycle, Processes, Precipitation, Interception, Infiltration, Evaporation, Transpiration, Evapotranspiration, Runoff
- **Keywords:** Hydrologic cycle, Precipitation, infiltration, Evapo-transpiration, Runoff

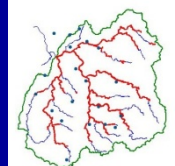
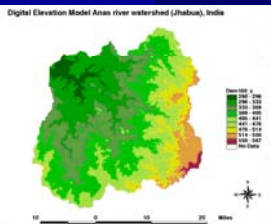

Hydrologic Processes

- Hydrologic information – for planning and management of watersheds.
- Hydrologically watershed conceptualized – Precipitation -> Runoff: Evaporation, Transpiration, Interception, Infiltration etc.
- Watershed: Overland flow, Channel flow & subsurface flow components.
- Hydrologic cycle – processes & pathways in circulation of water from land & water bodies to atmosphere & back again – Land use effects

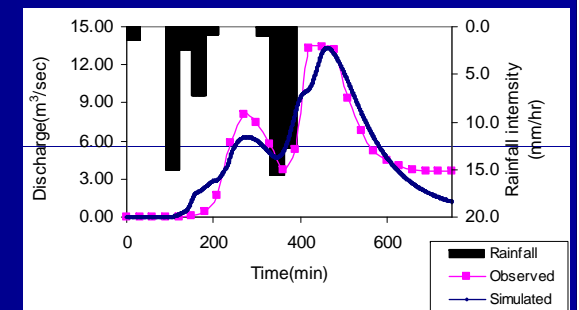
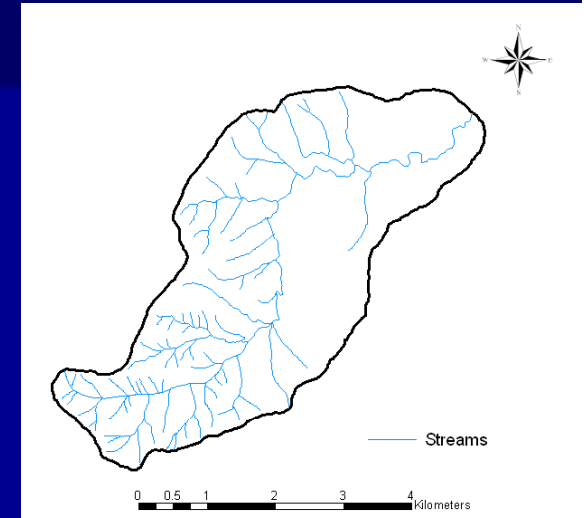

WATERSHED MANAGEMENT



Hydrologic Cycle & Processes

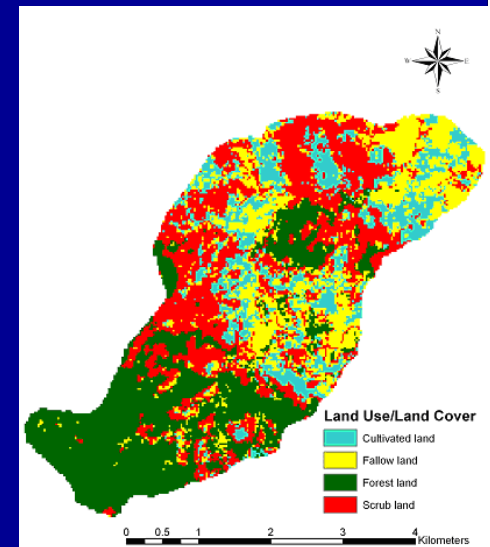
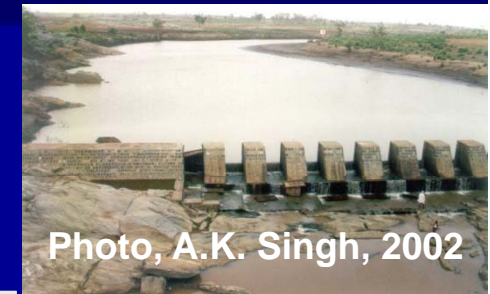
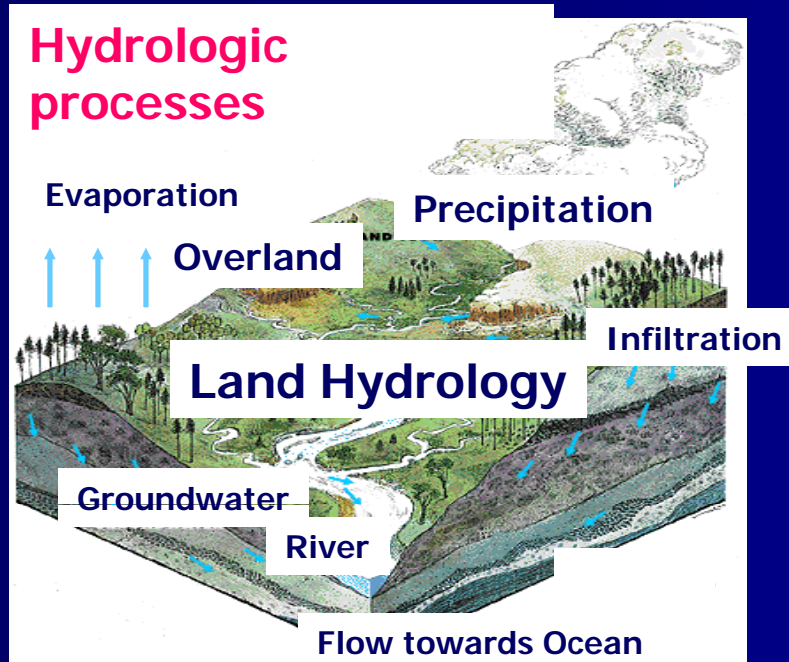

Hydrosphere & hydrological cycle –
Hydrological processes - balance between
water of the earth & moisture in atmosphere

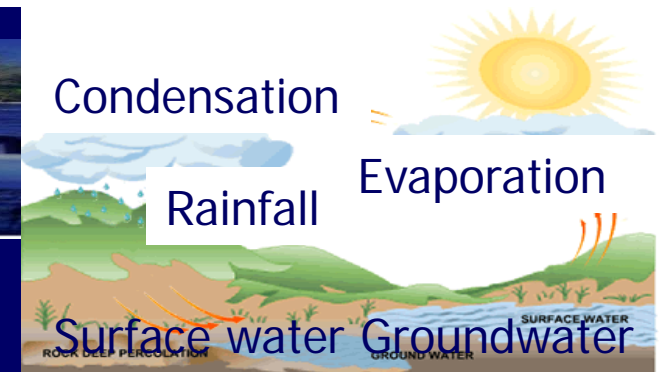

Precipitation

- Precipitation in several forms: Rain (water droplets > 0.5mm dia.); Drizzle (<0.5mm dia), Snow (in ice form), Sleet, Hail stone, Dew.
- Precipitation – Main source of water: Rain & snow.
- **Precipitation condition:** Humid air cooled to dew-point -> Nuclei -> Droplets to raindrops;->Size of raindrops.
- Four main mechanisms for cooling the air to its dew point: adiabatic cooling, conductive cooling, radiational cooling, and evaporative cooling
- Approx. 505,000 cubic km of water falls as precipitation each year; 398,000 cubic km- over the oceans & 107,000 cubic km over land.
- Globally averaged annual precipitation is 990 mm, but over land it is only 715 mm

Precipitation & Measurement

- Occurs when air masses laden with water vapor are cooled; Storm Precipitation 3 Types: Frontal storm, Convective storm & orographic storm.
- Rainfall: Measurement & analysis – very important
- Rainfall data: Amount, intensity & duration
- Rainfall in mm & intensity in mm/hour.

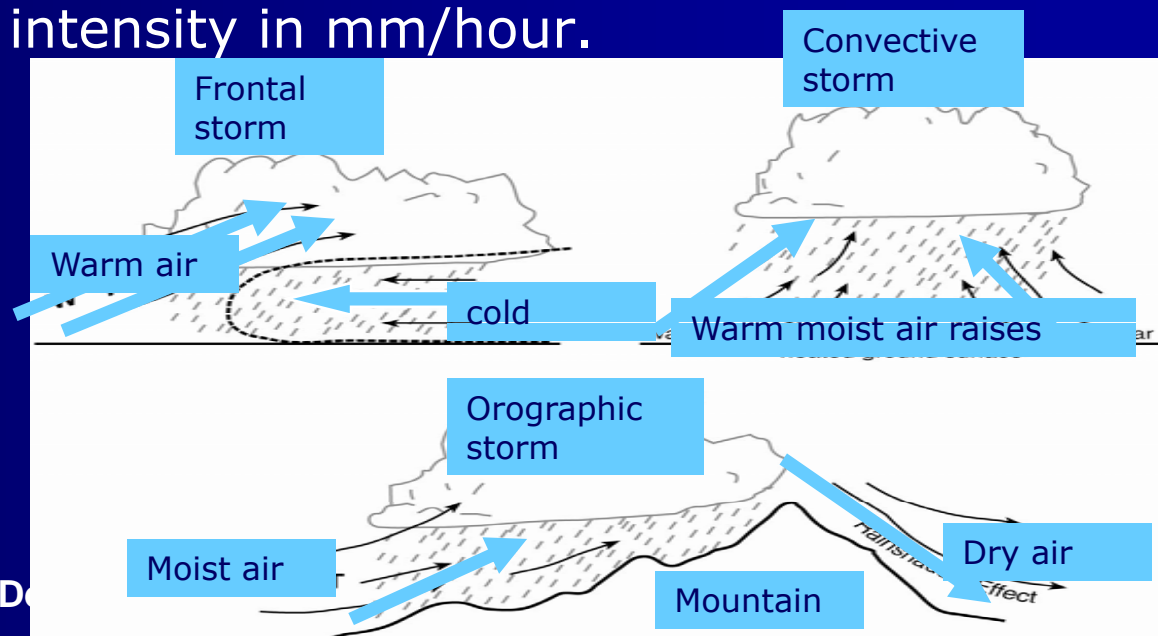

WATERSHED MANAGEMENT

Rainfall & Measurement



- Rainfall: measured as vertical depth of water collected on a level surface.
- Measurement by **Rain gauges**:
- **Non-recording type**: collects rainfall over a known period of time – intensity can not be correctly found; IMD – Standard Gauge: Collector with gun metal rim, funnel, base & polyethene bottle; Collector area– 100cm²/ 200cm²; Polyethene bottle – 2, 4 & 10 lit.; measurement by graduated measuring cylinder.
- **Recording type**: give rainfall intensity – mechanical system – record on graph paper; Curve of cumulative rainfall with time: Mass curve; Slope of curve – rainfall intensity.
 - Types: Float; Weighing & Tipping bucket; Clock driven rotating drum, pen fitted graph paper.

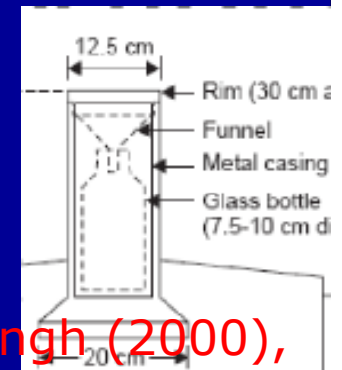

Prof. T I Eldho, Department of Civil Engineering, IIT Bombay

<http://www.fao.org>

Raj Vir Singh (2000),

Rainfall Intensity, Duration & Frequency

- Rainfall Intensity: Rate at which rainfall occurs – mm/hr
- Duration: in hours/ days
- Return period (recurrence interval) – period within which depth of rainfall for a given duration will be equaled or exceeded once on the average
- $T = \text{Return period in years} = (N+1) / m$; N – total number of hydrologic events; m – rank of events arranged in descending order of magnitude
- **Probability of occurrence** of an event in %: $P = 100/T$
- Intensity of a storm - predicted for any return period & storm duration, from charts based on historic data.
- **1 in 10 year storm** describes a rainfall event which is rare & is only likely to occur once every 10 years, so it has a 10 percent likelihood any given year

WATERSHED MANAGEMENT



Average depth of rainfall over an area

- Large differences in rainfall – within short distances
- Average depth of rainfall to be found:
- Arithmetic average: for evenly distributed stations (uniform density): $P_a = \sum P_i / N$
- Thiessen method: area-weighted averaging – used when rain gauges are nonuniformly distributed:
Area-weighted average : (every gauge represents best the area immediately around the gauge)

Constructing Thiessen Network:

1. Plot stations on a map
2. Connect adjacent stations by straight lines
3. Bisect each connecting line perpendicularly
4. Perpendicular lines define a polygon around each station
5. P at a station is applied to the polygon closest to it

WATERSHED MANAGEMENT

Average depth of rainfall over an area

- Average depth of rainfall in a watershed:
- $P = (A_1 P_1 + A_2 P_2 + \dots + A_n P_n) / A$
 - A – area of watershed; P1, P2,Pn – rainfall depth in the polygon having areas A1, A2, ...An within the watershed.
- Isohyetal method: record depth of rainfall at locations of different rain gauges & plot isohyets (lines of equal rainfall)
- Plot a contour map of P based on gage readings at stations
- Compute area between each successive contour lines

$$P_a = \frac{\sum P_{ai} A_i}{\sum A_i}$$

Prof. T I Eldho, Department of Civil Engineering, IIT Bombay

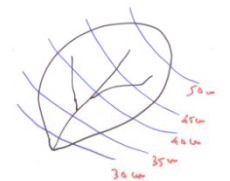
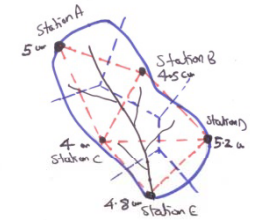



Interception

- **Interception:** part of precipitation collects on the plant canopy; ultimately evaporates – abstraction from precipitation – quantified.
- Amount of interception depends: Storm character; vegetation, growth stage, season & wind velocity.
- Importance of interception- purpose of hydrologic model - Significant in annual or long term model
- Potential storm interception calculation: $L_i = S + K E t$
 - L_i = volume intercepted, S = interception storage
 - K = ratio of surface area of intercepting leaves to horizontal projections of the area; E = the amount of water evaporated per hour during the precipitation period, t = time (hr)
- Assumption: rainfall is sufficient to satisfy S
- For accounting rainfall (P): $L_i = S(1 - e^{-P/S}) + K E t$



Surface Retention / Detention

- Depression storage / surface retention: water retained on the ground surface in micro-depressions
 - this water will either evaporate or infiltrate into the soil
 - Nature of depressions as well as their size is largely a function of the original land form and local land use practices and erosion pattern.
- Surface detention: Water temporarily detained on the surface –
 - necessary requirement for surface runoff to occur –part of surface runoff
 - Controlling factors: surface micro-relief, vegetation, surface slope, topography, rainfall excess.



Infiltration

Infiltration: process by which water on the ground surface enters the soil.

- **Infiltration capacity** of soil determines – amount & time distribution of rainfall excess for runoff from a storm.
- **Important for estimation** of surface runoff, subsurface flow & storage of water within watershed.
- **Controlling factors:** Soil type (size of particles, degree of aggregation between particles, arrangement of particles); vegetative cover; surface crusting; season of the year; antecedent moisture; rainfall hyetograph; subsurface moisture conditions etc.

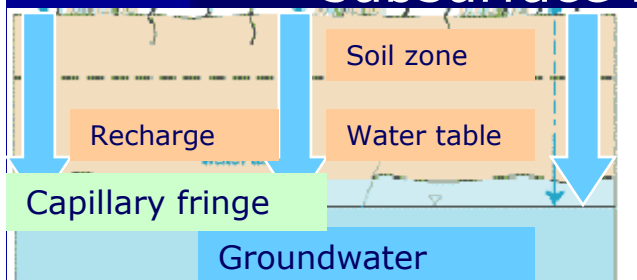

Infiltration Estimation

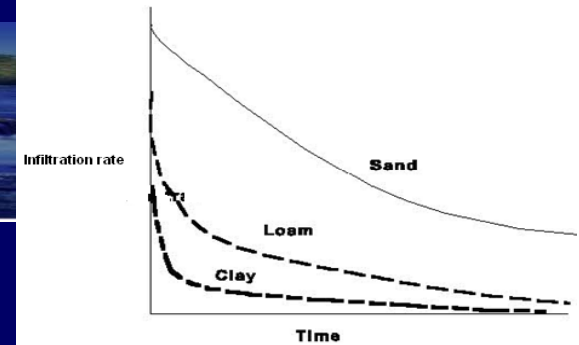

(Ghanshyam Das, 2000)

- Infiltration measured – Infiltrimeters & rainfall runoff plots.
- Entry of water into soil surface measured on a small plot of soil.
- Infiltration rate: Volume per unit of time per unit of area or depth per unit time.
- Number of methods to estimate infiltration.
- Important methods: Horton equation; Green-Ampt eqn.; Philips eqn.; Darcy's eqn.; SCS eqn.; Holtan eqn.; Kostiakov eqn. etc.



Infiltration Estimation

- **Horton Eqn.:** infiltration starts at a constant rate f_0 & is decreasing exponentially with time t : $f_t = f_c + (f_0 - f_c)e^{-kt}$
Where f_t - infiltration rate at time t ; f_c - initial infiltration rate or maximum infiltration rate; f_0 - constant or equilibrium infiltration rate after the soil has been saturated or minimum infiltration rate; k - decay constant specific to the soil.

- **Philip Infiltration Model:**

$$f = \frac{1}{2} s_i t^{-1/2} + K$$

- where s_i is infiltration sorptivity ($\text{cm} \times \text{hr}^{-0.5}$), K is hydraulic conductivity which is considered equal to the K_s and t is time.

Infiltration Estimation

- Holton's empirical infiltration equation $f = GI A S_a^{1.4} + f_c$
 - f is in inches per hour, GI is a crop growth index that ranges from 0.1 to 1.0, A - macropores associated with plant roots, f_c - steady state infiltration rate, S_a - available storage in the surface layers.
- **Infiltration Index: for determination of loss of rainwater due to abstraction.** Method assumes constant value of infiltration capacity (for the full duration of storm)
- Φ - index: Average abstraction of rainfall
- w -index: Considers initial abstractions; very difficult to determine correct values of initial abstraction

Evaporation

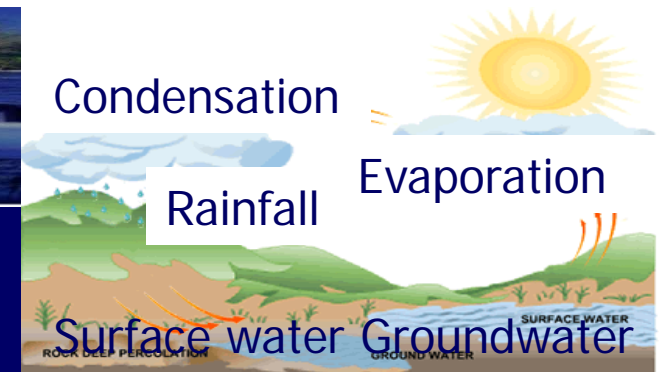

- **Evaporation:** process where liquid water is transformed into a gaseous state at a temperature less than the boiling point through the process of transfer of heat energy.
 - Evaporation of water occurs when the surface of the liquid is exposed, allowing molecules to escape and form water vapor.
 - This vapor can then rise up and form clouds
 - Evaporation – essential part of water cycle.
- **Factors affecting evaporation:** solar radiation; differences in vapor pressure between water surface & overlying air; relative humidity; temperature; Wind; atmospheric pressure

Measurement of Evaporation

- Exact measurement of evaporation - for large bodies of water difficult
- From open water surfaces – evaporation measured by: Atmometers, evaporimeters or open pans
- **Evaporation pans:** finding reservoir evaporation using water filled containers -observe how much water is lost over time
- Different types of pans
 - US class A pan
 - ISI standard pan
 - Colorado sunken pan
 - Russian GGI pan
 - Pan Coefficient: (Ratio of lake to pan evaporation)

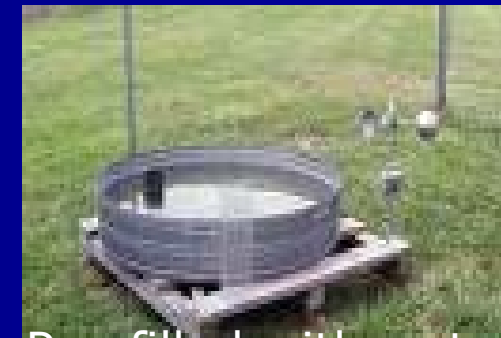

Pan filled with water
www.meted.ucar.edu

Evaporation Estimation

- Water Budget Method: from ponded water – lakes/ reservoirs: Water budget method – accounting all inflows and outflows.
- Energy Budget Method: based on application of law of conservation of energy – evaporation takes energy.
- Mass Transfer (Aerodynamic) methods - based on turbulent transfer of water vapor from an evaporating surface to the atmosphere
- Combination- mass transfer & energy budget Method
- Empirical Formulas: using available meteorological data: eg. USGS & USBR Formula: $E = 4.57T + 43.3$
- E - cm/yr; T - mean annual temperature in °C.
- Use of Evaporation Pans

Evaporation Control

- Storing water in covered reservoirs
 - Making increased use of underground storage
 - Controlling aquatic growths
 - Building storage reservoirs with minimal surface areas
 - Conveying in closed conduits rather than open channels
 - Applying a thin chemical (monocular) film
- Eg: Application of Cetyl alcohol is the effective and feasible method
- Reduces evaporation (20-50%) by preventing the water molecules to escape
 - No water quality effect: Colorless, odorless and nontoxic

Transpiration

- **Transpiration:** vaporization of liquid water contained in plant tissues & vapor removal to the atmosphere.
- Crops predominately lose their water through stomata. These are small openings on the plant leaf through which gases and water vapor pass
- Nearly all water taken up is lost by transpiration and only a tiny fraction is used within the plant.
- Transpiration depends on the energy supply, vapor pressure gradient and wind, soil water content and the ability of the soil to conduct water to the roots, crop characteristics, environmental aspects and cultivation practices.
- 95% of daily transpiration occurs during daylight hours

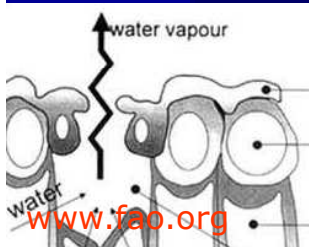

Transpiration & Evapotranspiration

- Soil moisture lies between the limits of wilting point and field capacity- No effect on transpiration
- Phytometer – device for measuring transpiration
- **Evapotranspiration (ET)**: Evaporation and transpiration occur simultaneously and there is no easy way of distinguishing between the two processes.
- **Potential evapotranspiration (PET)**: Rate at which water, if available, would be removed from wet soil & plant surface, expressed as the latent heat transfer per unit area or its equivalent depth of water per unit area.
- PET - measure of ability of atmosphere to remove water from the surface through processes of E & T assuming no control on water supply.
- Actual evapotranspiration (AET) -quantity of water actually removed from a surface due to the processes of E & T

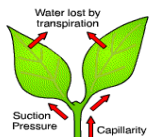

Water intake through root



Estimation of Evapotranspiration

- **Crop water need** = potential evapotranspiration - actual evapotranspiration
- Crop Coefficient = AET / PET
- Theoretical Methods: Blaney Criddle, Penmann – Monteith method
- Empirical Methods: Thornthwaite
- Field Methods: Lysimetres (device in which a volume of soil, with or without crop is located in a container to isolate it hydrologically from surrounding), Field plots, Soil moisture depletion studies
- Analytical Methods - Energy or Water budget method

Estimation of Evapotranspiration

■ Blaney - Criddle Method:

- Assumption: Consumptive use of water by crops is related to mean monthly temp. & daylight hours; Provide rough estimate
- For extreme climatic conditions -method is inaccurate
- Windy, dry, sunny areas - ET_0 is underestimated (up to 60 %)
- Calm, humid, clouded areas- ET_0 is overestimated (up to 40%)

Blaney-Criddle formula: $ET_0 = p (0.46 T_{mean} + 8)$

- ET_0 = Reference crop evapotranspiration (mm/day) as an average for a period of 1 month
- T_{mean} = mean daily temperature (°C)
- p = mean daily percentage of annual daytime hours



Photo, A.K. Singh, 2002

Surface Runoff

- **Surface Runoff:** part of precipitation which during & immediately after a storm event, appears as flowing water in the drainage network of a watershed.
- Result from direct movement of water over the surface of watershed, precipitation in excess of abstraction demand or emergence of soil water into waterways.
- **Surface runoff** occurs – when the rate of precipitation exceeds the rate of infiltration.
- **Controlling Factors:** i) Climatic factors; ii) Physiographic
 - Climatic factors: Precipitation (intensity, duration, areal distribution & storm pattern), evaporation & evapotranspiration.
 - Physiographic factors: watershed characteristics (size, shape, land use, infiltration rate, slope etc.), channel characteristics (size, cross section, slope & roughness of channel bed) & drainage pattern & density.

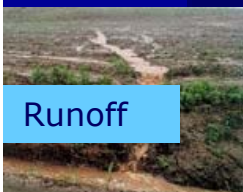

Runoff

WATERSHED MANAGEMENT



Surface Runoff

- **Overland & Channel Flow:** If rainfall exceeds soil infiltration capacity, water fills surface depression then Water spills over down slope as overland flow & eventually to the stream – channel flow
- Surface runoff - generated either by rainfall or by the melting of snow, or glaciers
- **Measurement of Runoff**
- Pass through outlet of watershed
- Flume measurement – H flume
- Automatic water stage recorder

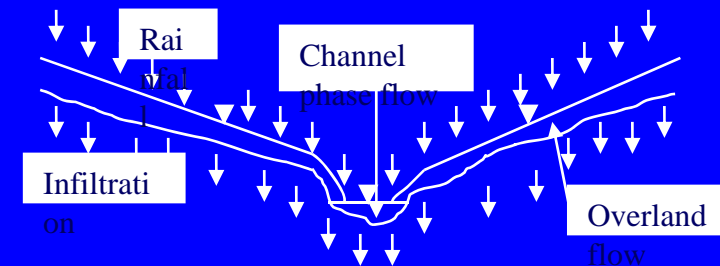
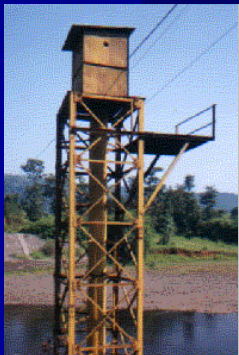

Surface Runoff Mechanism

- **Infiltration excess overland flow (Hortonian / Unsaturated overland flow):** occurs when rate of rainfall on a surface exceeds rate at which water can infiltrate the ground, & any depression storage has already been filled.
- **Saturation excess overland flow:** When soil is saturated & depression storage filled, & rain continues to fall, rainfall will immediately produce surface runoff.
- **Antecedent soil moisture:** Soil retains a degree of moisture after a rainfall - residual water moisture affects the soil's infiltration capacity
- **Subsurface return flow (through flow):** after water infiltrates the soil on an up-slope portion of a hill- water may flow laterally through the soil, & exfiltrate (flow out of the soil) closer to a channel.



Runoff

Steps to Hydrologic Modeling

1. Delineate watershed
2. Obtain hydrologic and geographic data
3. Select modeling approach
4. Calibrate/Verify model
5. Use model for assessment/prediction/design
 - **Use of Models:**
 - Assessment: What happens if land use/land cover is changed?
 - Prediction: Flood forecasting
 - Design: How much flow will occur in a 10 year storm?



Example Problem

- Rainfall data for a 24 hour storm period recorded for 5 stations are given below. Find average rainfall by Thiessen method :

Station	Obs. Rainfall (cm)	Polygon area (km ²)	Rainfall volume m ³
A	5	4	200,000
B	4.5	3.5	157,500
C	4	6	240,000
D	5.2	5	260,000
E	4.8	4.5	216,000

$$\begin{aligned}\text{Weighted Average rainfall} &= \text{Total volume} / \text{Total area} \\ &= \underline{4.667 \text{ cm}}\end{aligned}$$

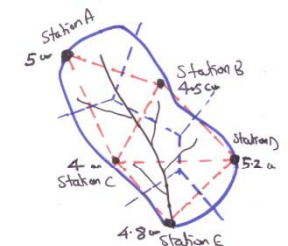

Example Problem

Determine reference crop evapotranspiration E_{To} in mm/day, for the month of April, using the Blaney-Criddle method (Latitude - 35° North, Mean T max in April = 27.5°C , Mean T min in April = 19.5°C)

Solution: Formula: $E_{To} = p (0.46 T_{\text{mean}} + 8)$

- Step 1: determine $T_{\text{mean}} = (27.5 + 19.5)/2 = 23.5^\circ\text{C}$

- Step 2: determine p :

Latitude: 35° North, Month: April, From standard Table $p = 0.29$

- Step 3: calculate E_{To} :

$$E_{To} = 0.29 (0.46 \times 23.5 + 8) = 5.45 \text{ mm/day}$$

Finally, the mean reference crop evapotranspiration $E_{To} = 5.45$ mm/day during the whole month of April

References

- Raj Vir Singh (2000), Watershed Planning and Management, Yash Publishing House
- J.V.S Murthy (1991), Watershed Management, New Age international Publications
- Ghanshyam Das (2000), Hydrology and soil conservation engineering, Prentice Hall of India
- [http://en.wikipedia.org/wiki/Infiltration_\(hydrology\)](http://en.wikipedia.org/wiki/Infiltration_(hydrology))
- <http://www.fao.org/docrep/s2022e/s2022e07.htm>
- Viessman and Lewis (2007), Introduction to Hydrology, Pearson Education.

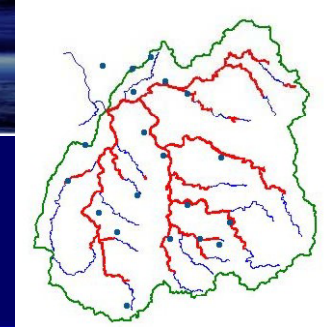

Tutorials - Question!..?.

- What are the different types of abstraction losses associated with rainfall?. For the development of watershed management plans, what are the important abstraction losses to be considered?.
- For typical watersheds in: a) tropic, b) semi-arid, and c) arid regions, identify the significance of each losses.
- Illustrate various methodologies used to quantify them.

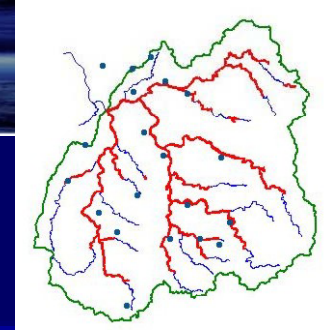

Self Evaluation - Questions!.

- Illustrate various hydrological processes within the context of hydrological cycle.
- Describe different types of rain gauges.
- Compare the Thiessen & Isohyetal methods for computing average rainfall & bring out the basic differences & advantages.
- Discuss different methods of evapo-transpiration estimation.

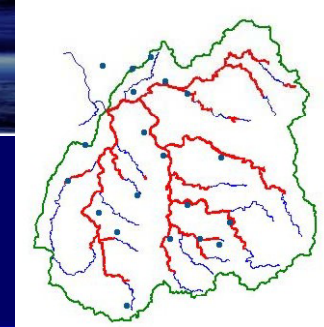

Assignment- Questions?.

- Describe important precipitation mechanisms.
- Discuss the importance of rainfall intensity, duration & frequency in runoff generation.
- Describe various methods of estimation of infiltration.
- Illustrate surface runoff and mechanisms of generation of surface runoff.

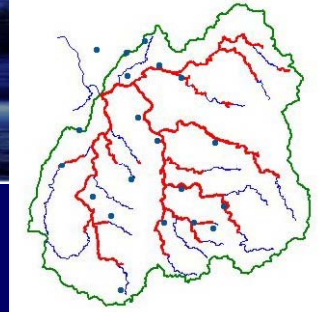

Unsolved Problem!.

- For your watershed area, obtain the rainfall data for the nearby rain gauge stations for few storms. Using various methods: a) arithmetic mean; b) Thiessen mean method; c) Isohyetal method, compute the average rainfall by all methods & compare.
- Draw the isohyets for the area consisting of the rain gauge network.
- Construct the Thiessen polygon.
- Compute the average rainfall.

WATERSHED MANAGEMENT

THANK YOU

Dr. T. I. Eldho

Professor,

**Department of Civil Engineering,
Indian Institute of Technology Bombay,
Mumbai, India, 400 076.**

Email: eldho@iitb.ac.in

Phone: (022) – 25767339; Fax: 25767302

<http://www.civil.iitb.ac.in>

