

# Dewatering

In 12<sup>th</sup> lecture, we have studied the principles of dewatering, hydrogeology of the area in terms of types of aquifers, permeability and design issues.

# Purposes for Dewatering

- **For construction excavations or permanent structures that are below the water table and are not waterproof or are waterproof but are not designed to resist the hydrostatic pressure**
- **Permanent dewatering systems are far less commonly used than temporary or construction dewatering systems**

# Common Dewatering Methods

- **Sumps, trenches, and pumps**
- **Well points**
- **Deep wells with submersible pumps**

# Dewatering Open Excavation by Ditch and Sump

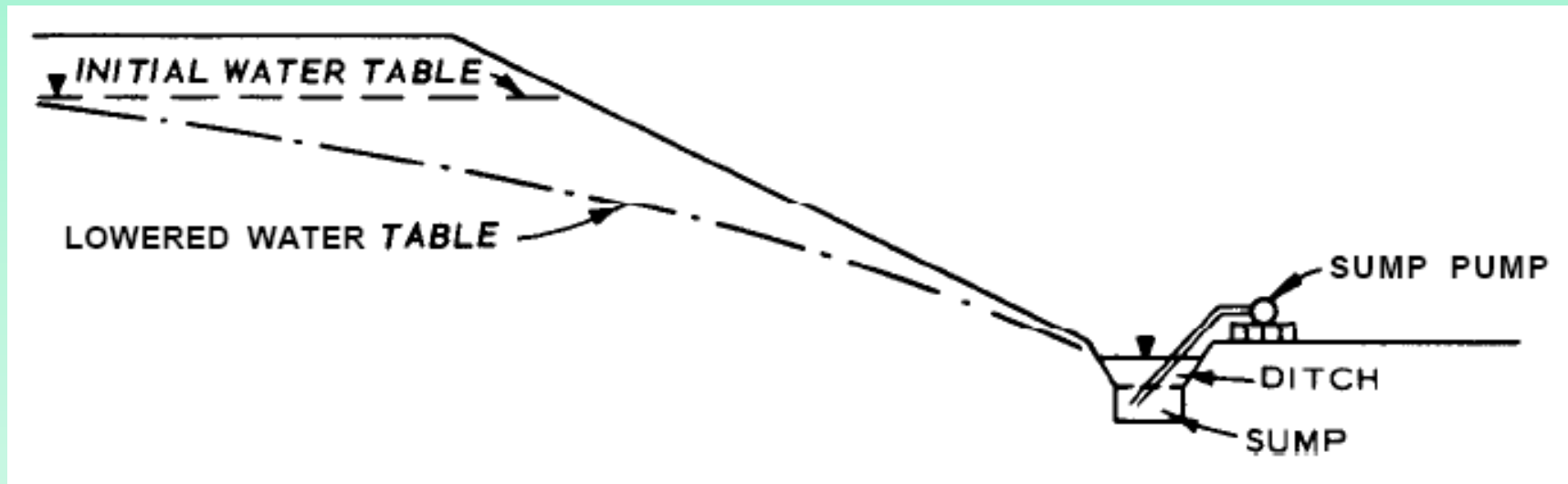

Army TM 5-818-5

# Single Stage Well Point System

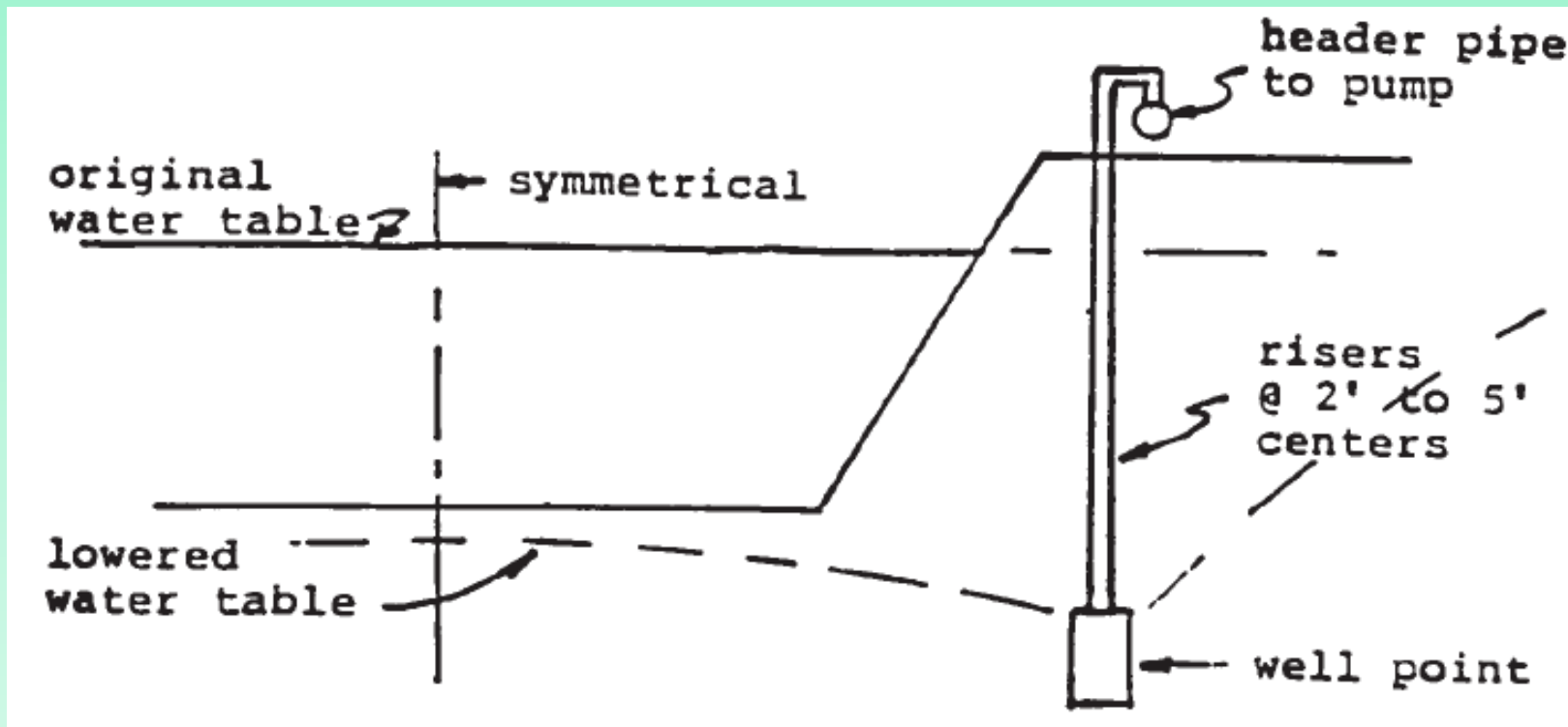

# Typical Well Point System

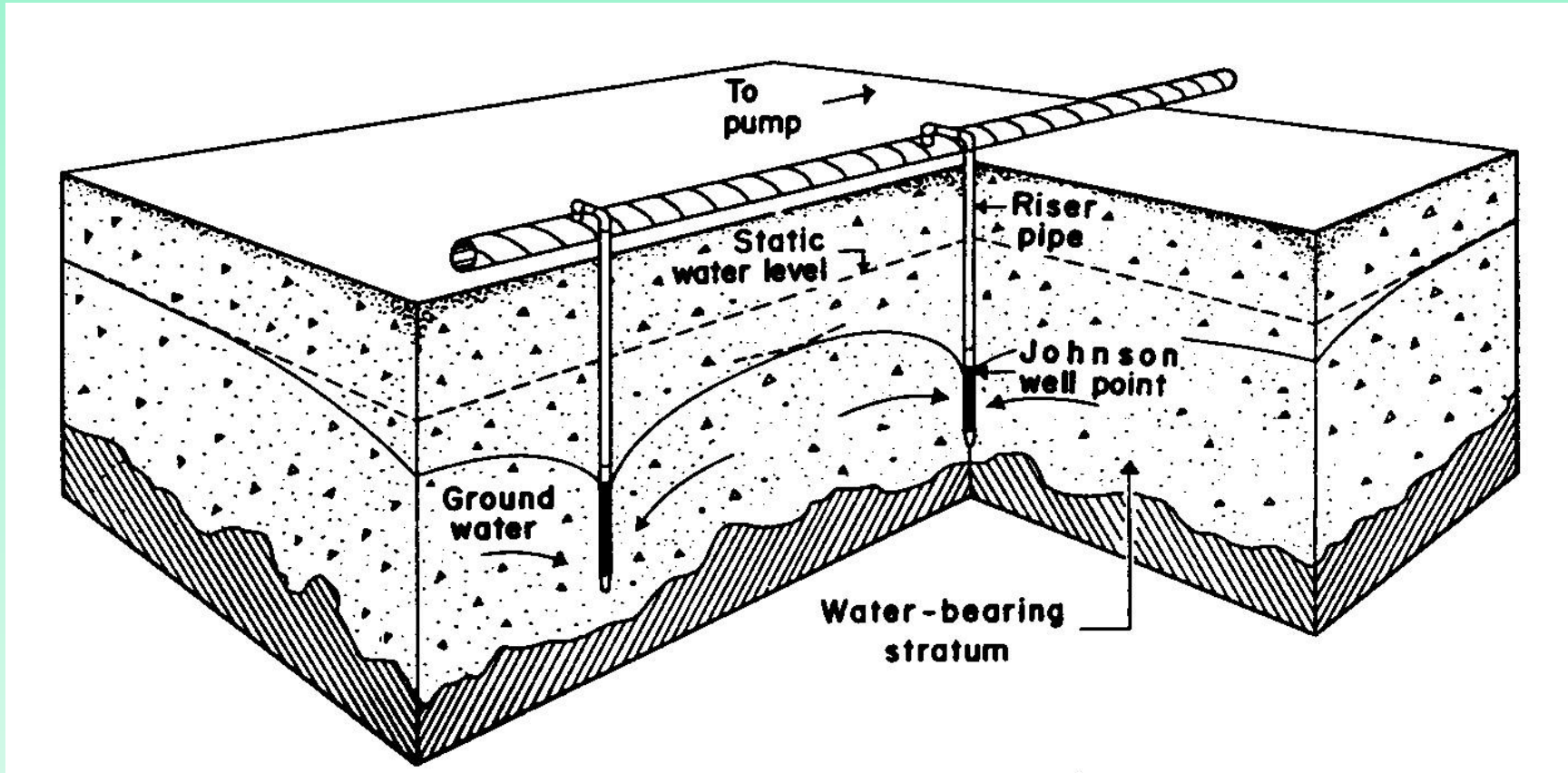

Johnson (1975)

# Applicability of Dewatering Systems

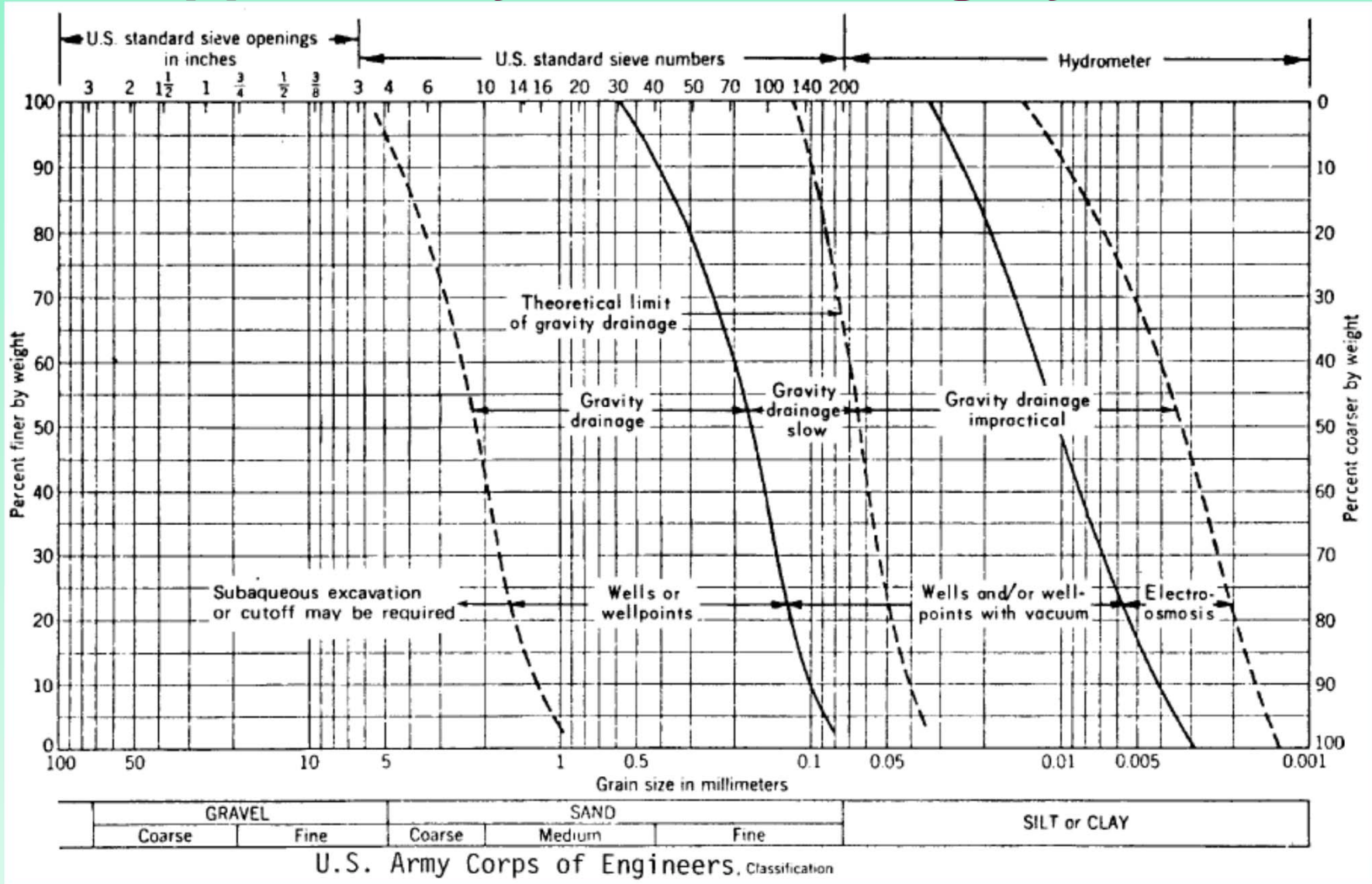

Army TM 5-818-5



# Permanent Groundwater Control System

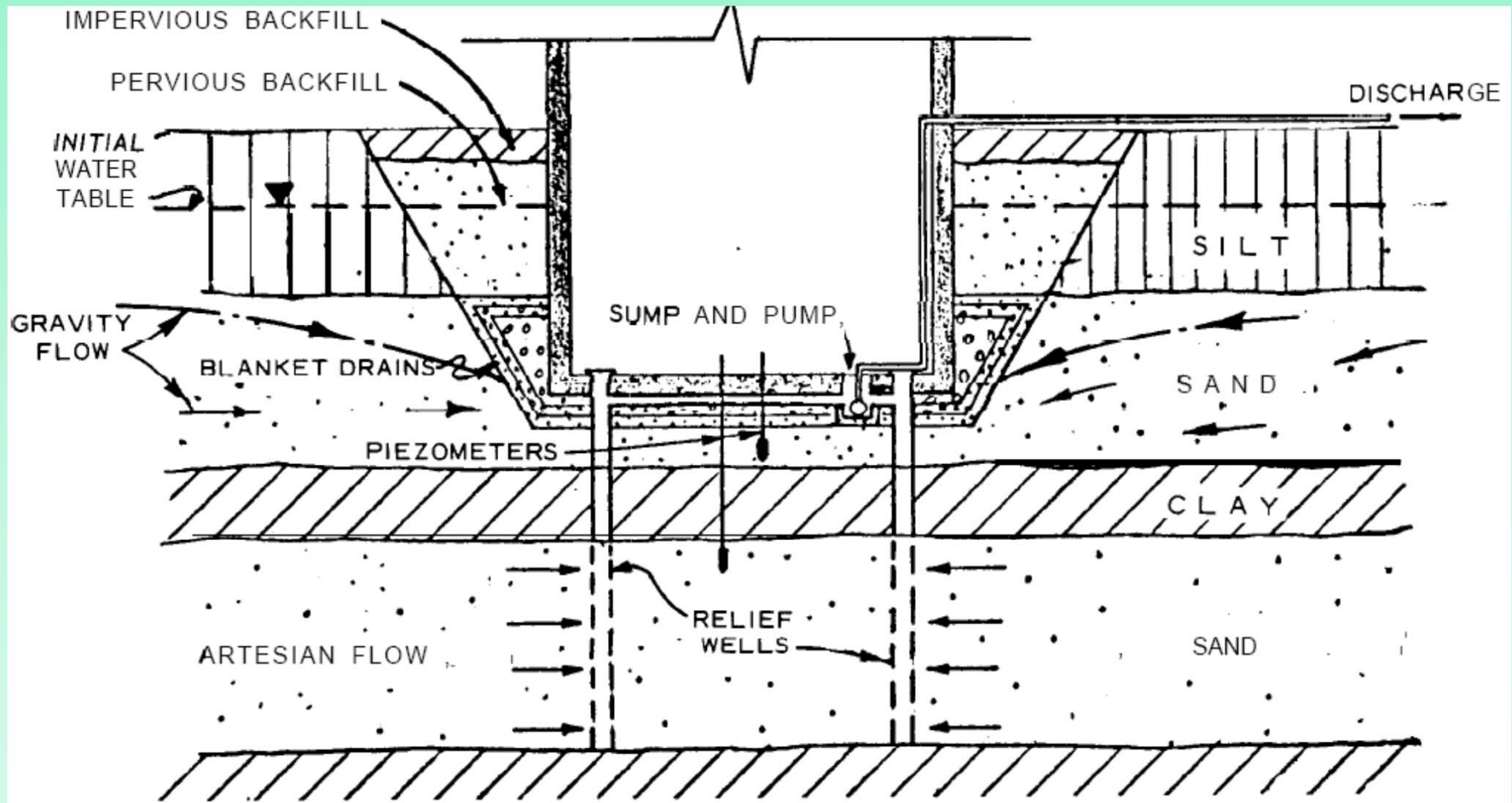

Army TM 5-818-5

# Buoyancy Effects on Underground Structure

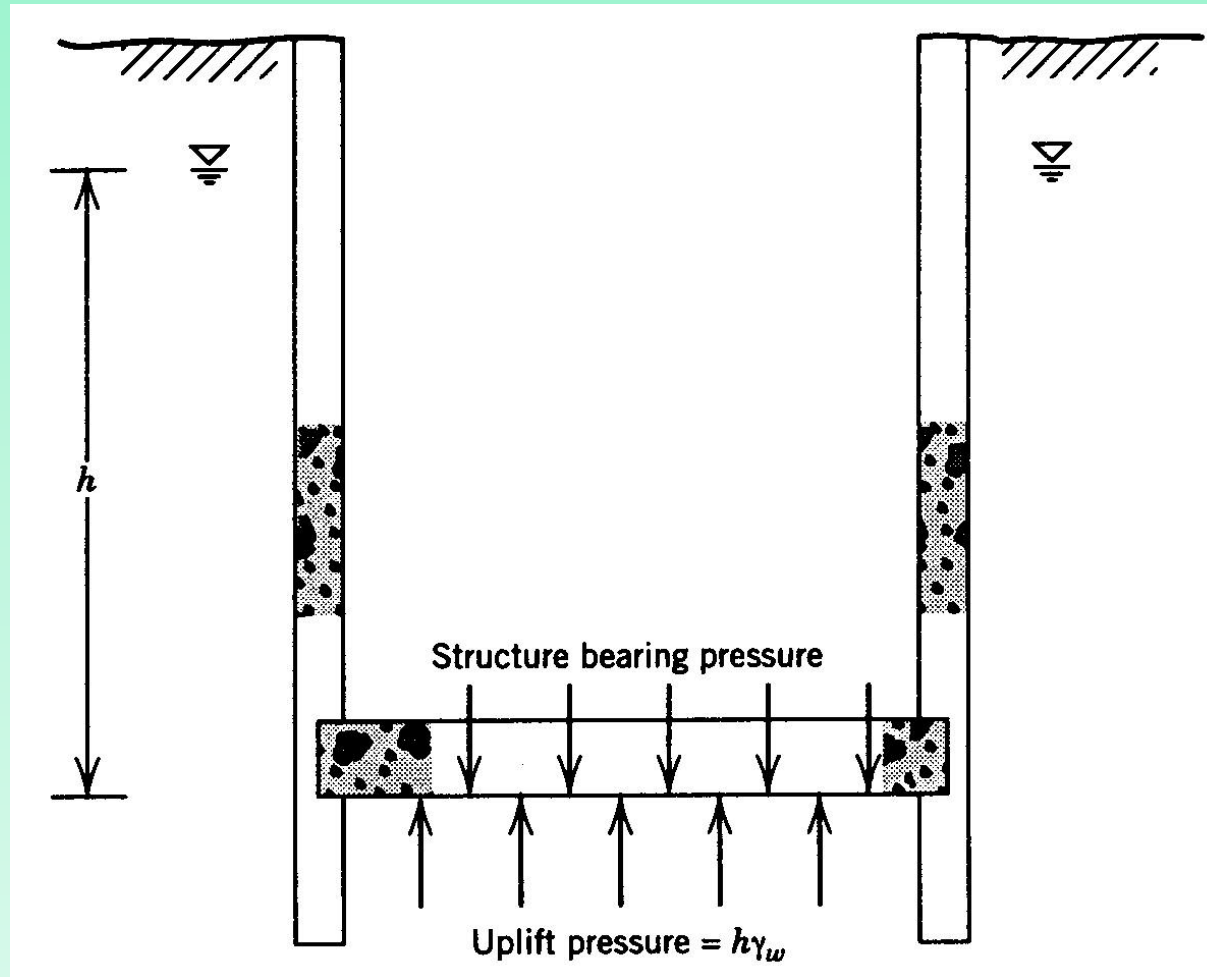

Xanthakos et al. (1994)

# Recharge Groundwater to Prevent Settlement

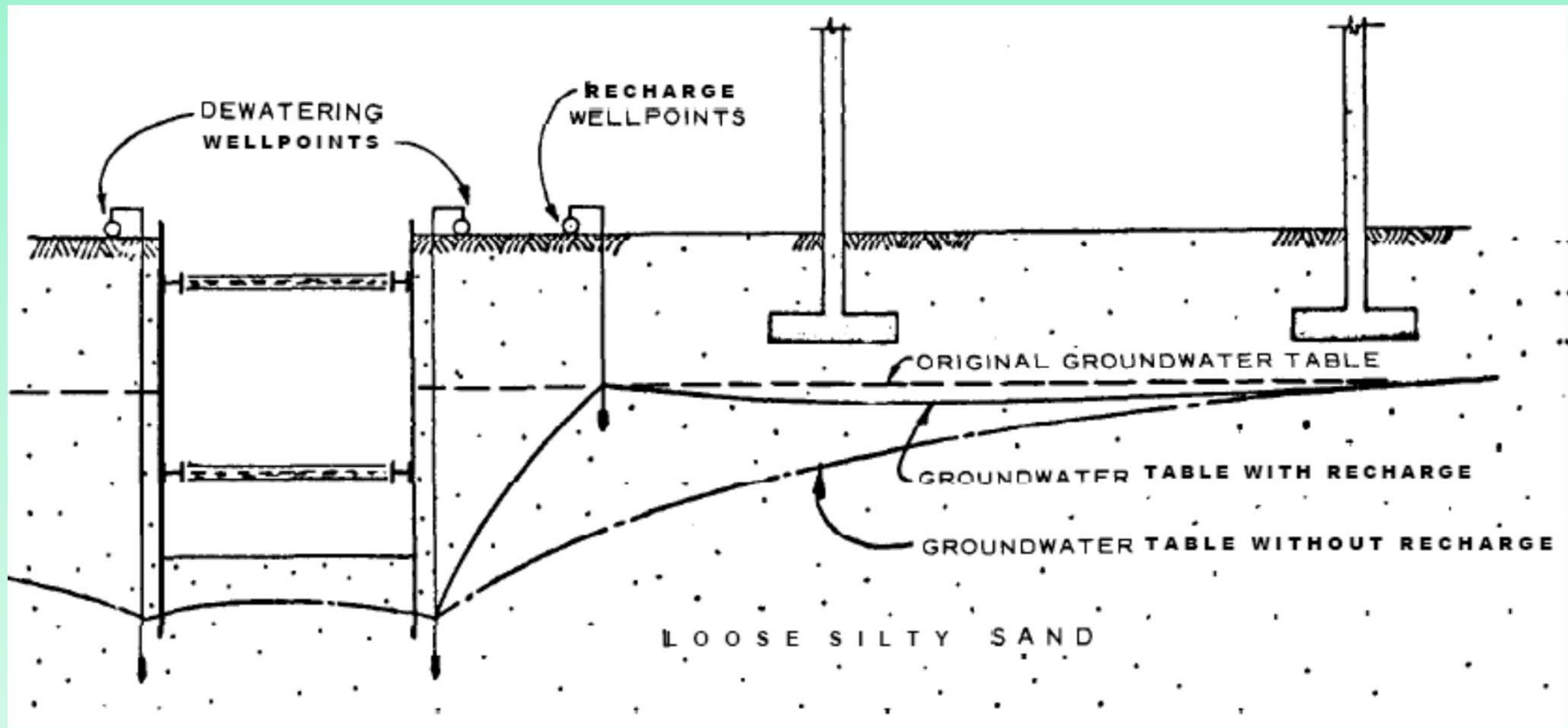

Army TM 5-818-5

# Settlement of Adjacent Structures

$$\delta = \frac{H}{1+e_0} C_c \log \frac{\sigma'_{vo} + \Delta\sigma}{\sigma'_{vo}}$$

$$\Delta\sigma = \Delta h \gamma_w$$

$\Delta h$  = reduction of groundwater level

Cut off walls/trenches are used to prevent the damage.

# Grout Curtain or Cutoff Trench around An Excavation

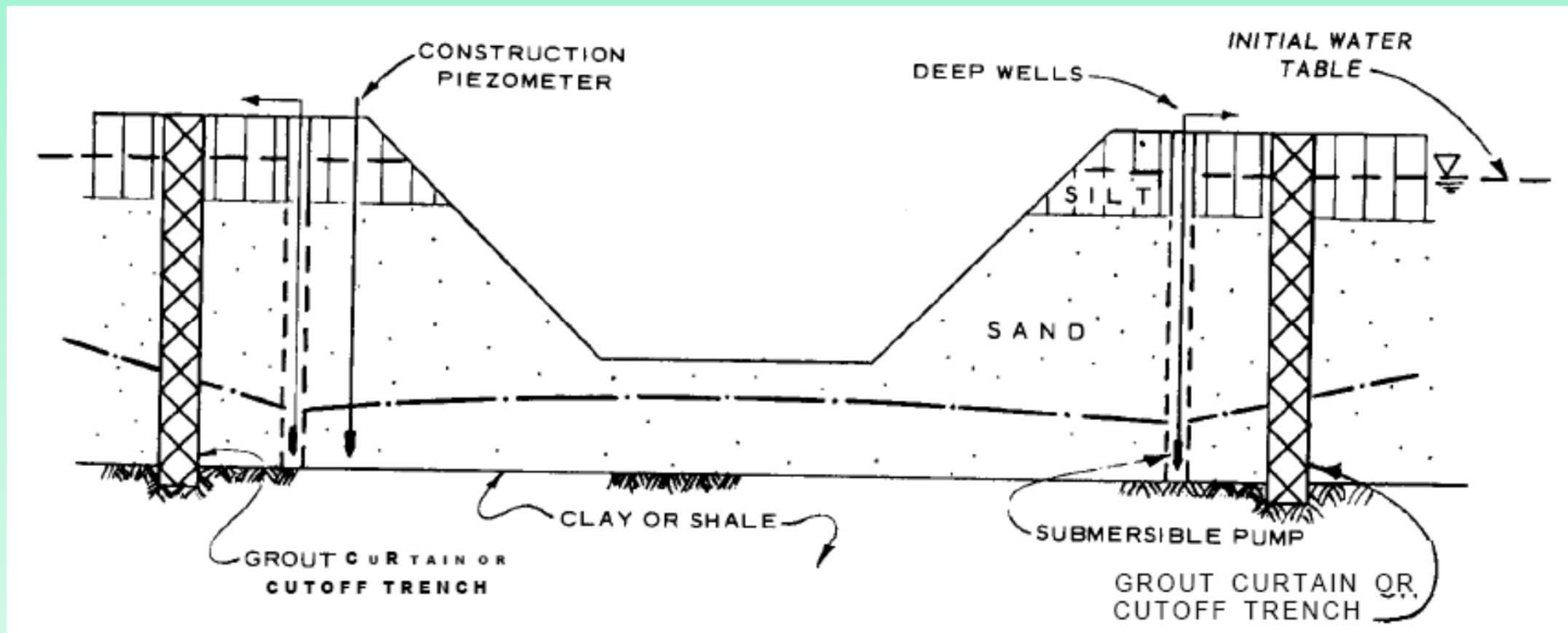

Army TM 5-818-5

# Sand Drains for Dewatering A Slope

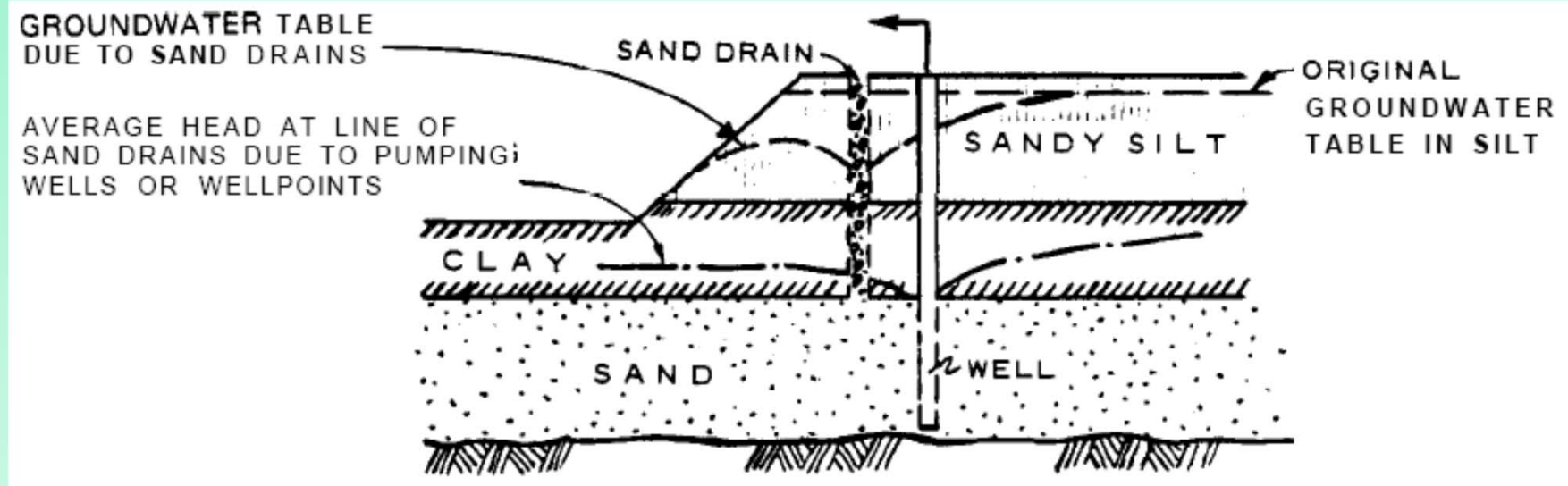

# Design Input Parameters

- **Most important input parameters for selecting and designing a dewatering system:**
  - the height of the groundwater above the base of the excavation
  - the permeability of the ground surrounding the excavation

# Dupuit-Thiem Approximation for Single Well

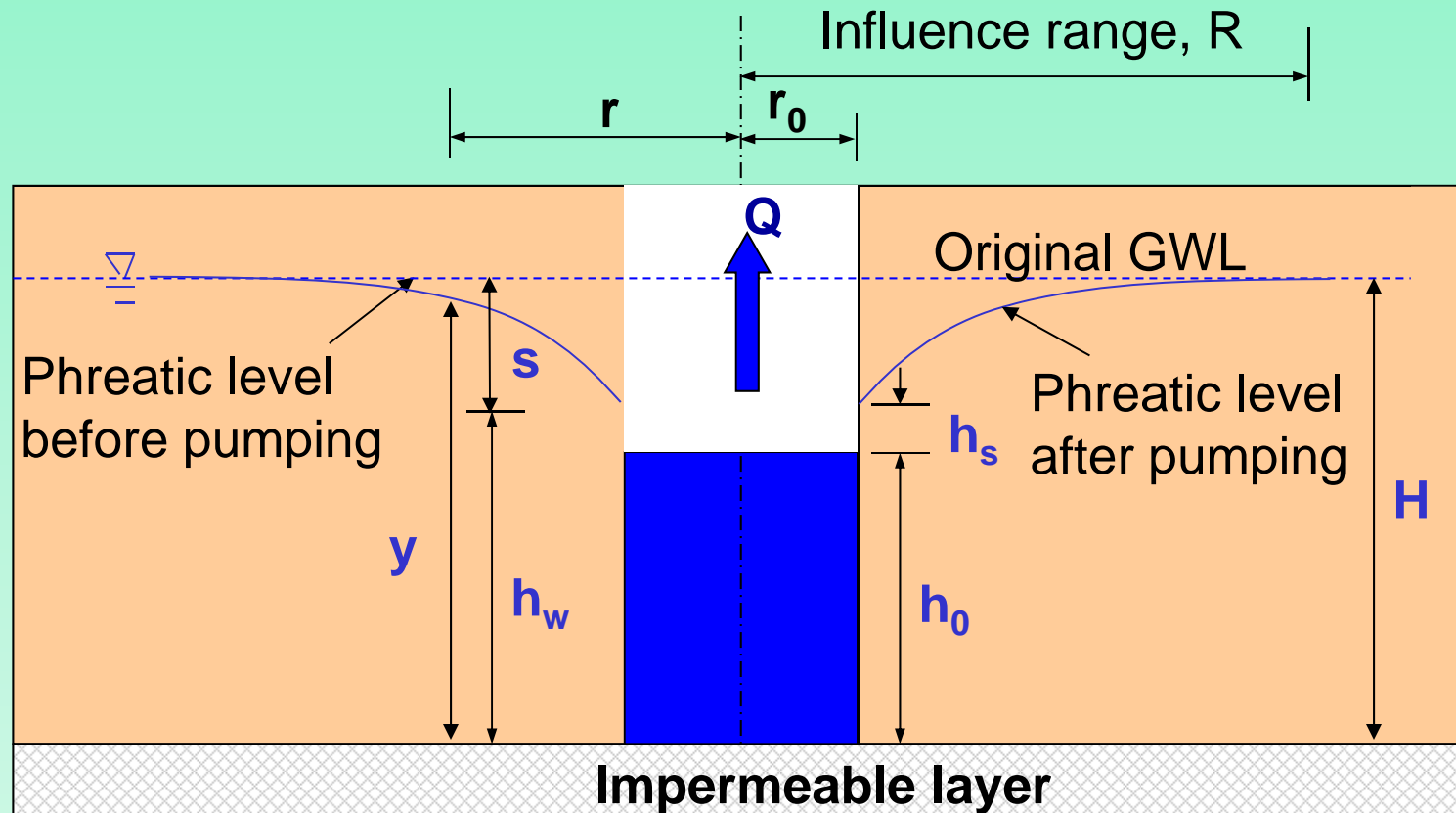

$$Q = \frac{\pi k (H^2 - h_w^2)}{\ln(R / r_0)} = 1.366k \frac{(H^2 - h_w^2)}{\log(R / r_0)} \quad y^2 - h_w^2 = \frac{Q \ln(r / r_0)}{\pi k}$$



# Height of Free Discharge Surface

$$h_s = \frac{C(H - h_0)}{H}$$

Ollos proposed a value of  $C = 0.5$

# Influence Range

Sichardt (1928)

$$L = C'(H - h_w)\sqrt{k}$$

C = 3000 for wells  
or 1500 to 2000 for single line well points

H,  $h_w$  in meters and k in m/s

# Forchheimer Equation for Multiwells

Forchheimer (1930)

$$Q = \frac{\pi k (H^2 - y^2)}{\ln L - (1/n) \ln x_1 x_2 \dots x_n}$$

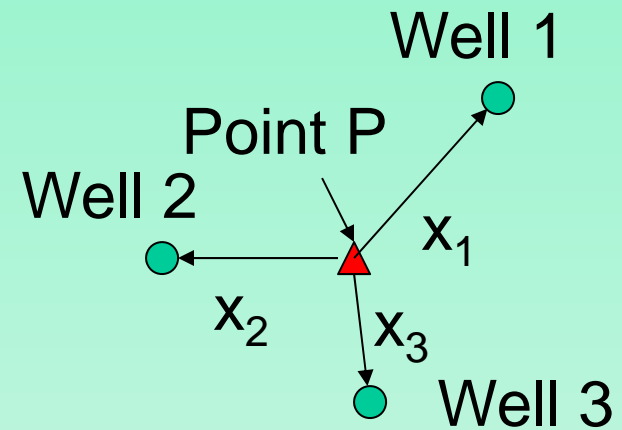

Circular arrangement of wells

$$Q = \frac{\pi k (H^2 - y^2)}{\ln L - \ln a}$$

Eq.1

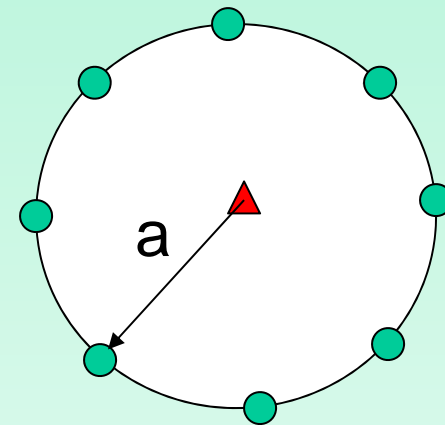

## Spacing of Deep Wells

- Obtain an estimate of the total quantity of water to be pumped from Eq.1. The values of H, y and R are determined by the type of aquifer, the required draw down and soil type. If a is the radius of the equivalent circular area and X and Y are the dimensions of the excavation,

$$a = \frac{Sq(XY)}{3.14}$$

- The number of wells is obtained by dividing the total yield with that of yield of a single well.

# Head vs. Discharge for Pump

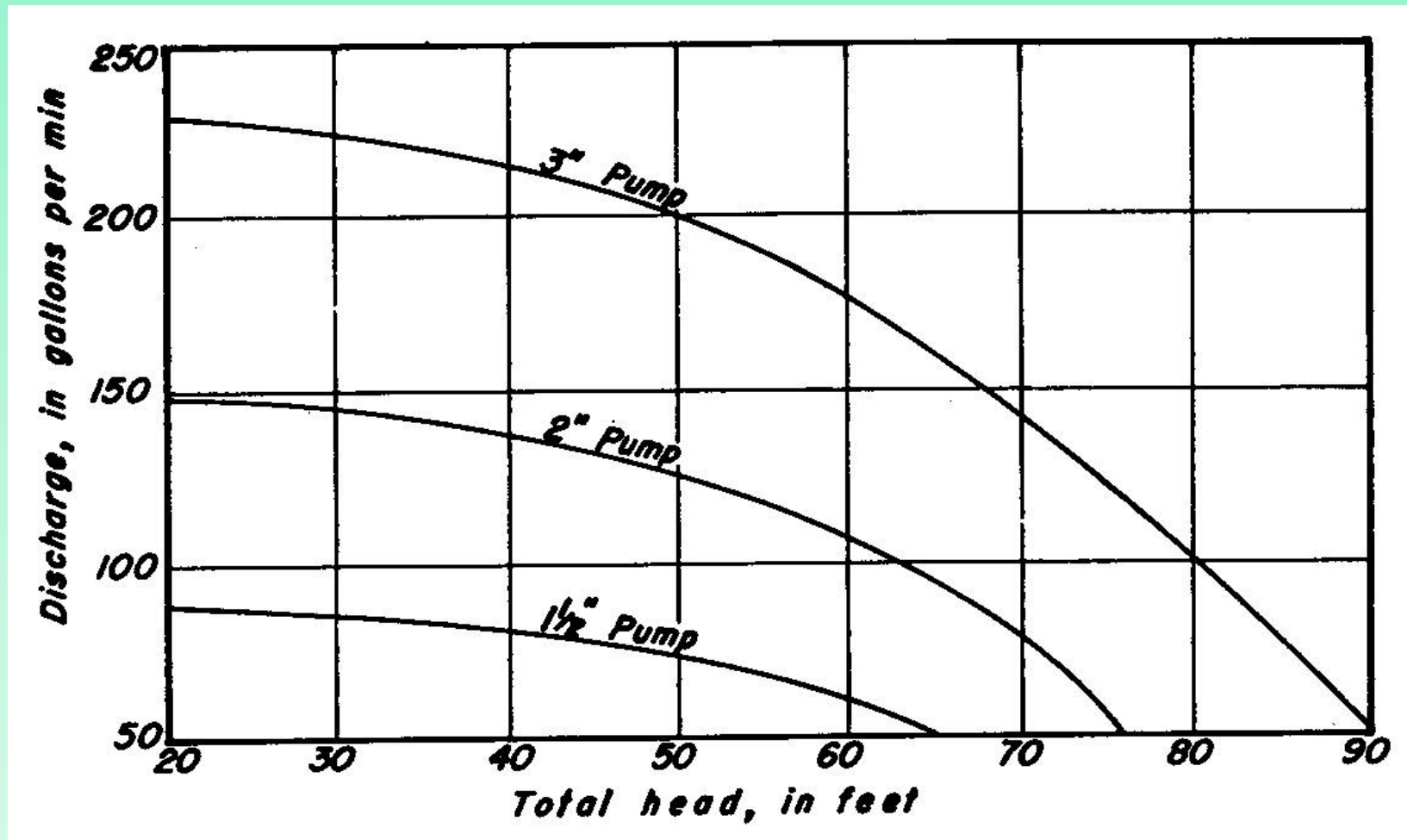

Carson (1961)

# Head vs. Discharge for Pump

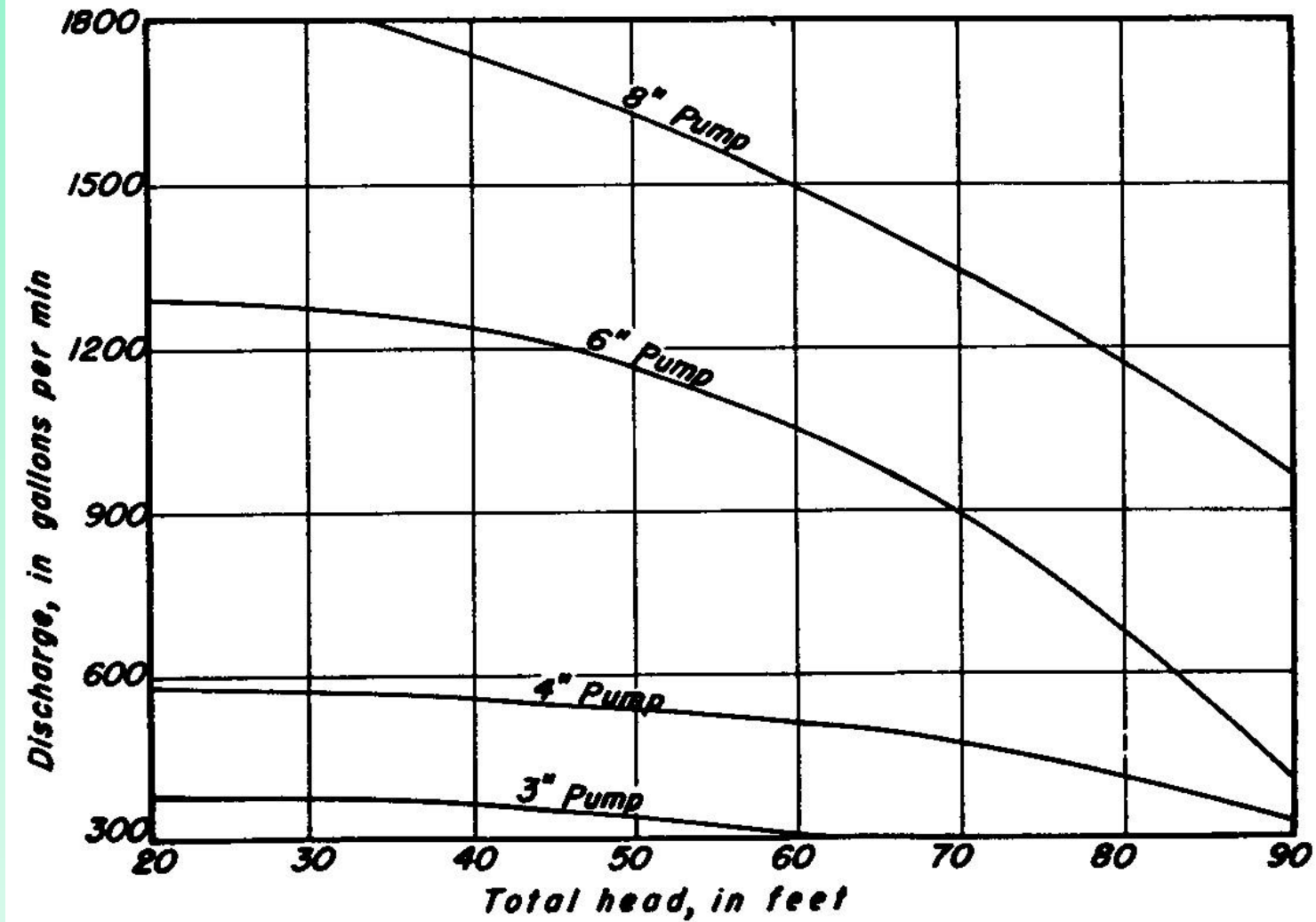

Carson (1961)

# Bottom Stability of Excavation

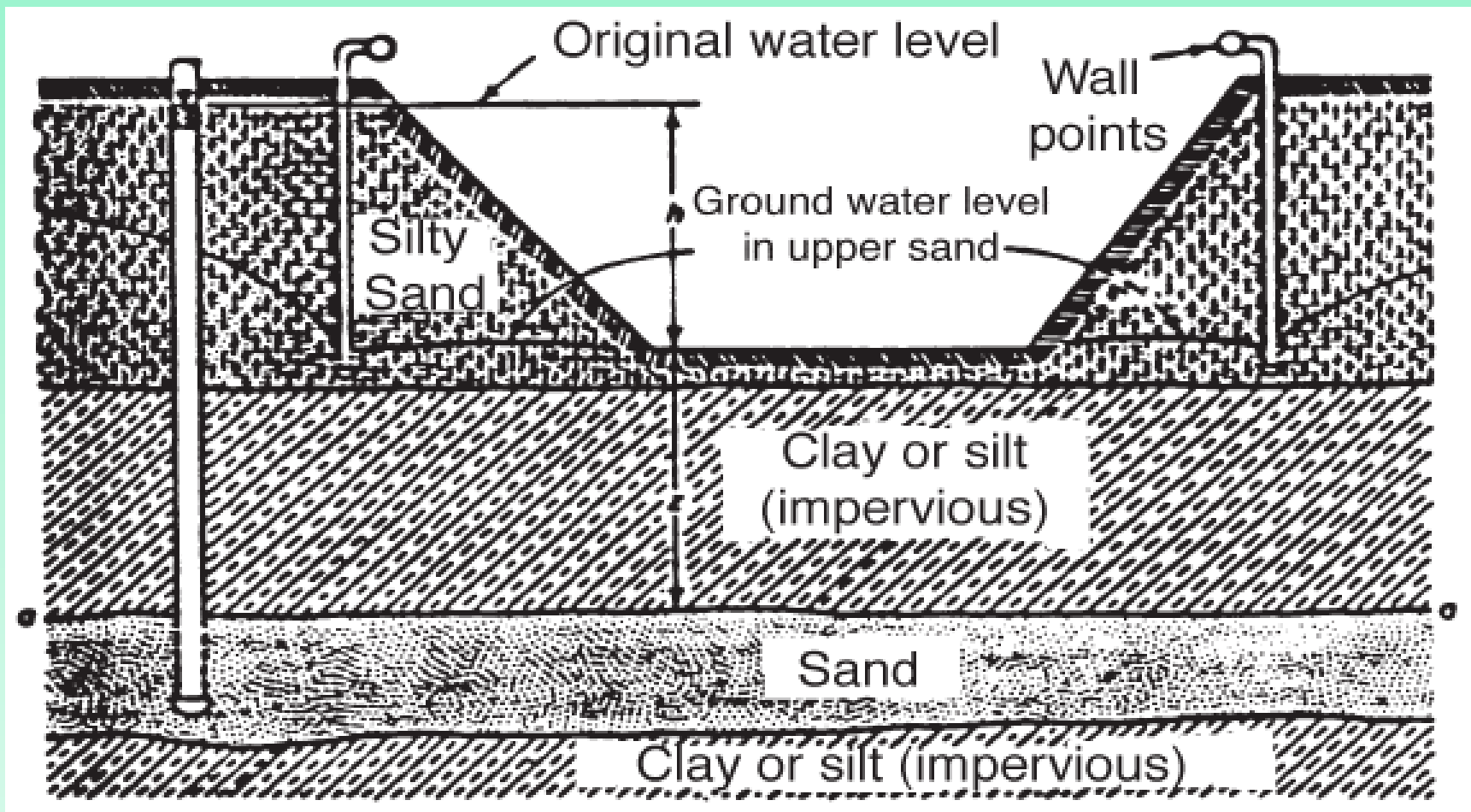

$$\gamma z > \gamma_w (h + z)$$

Caltrans

## Example:

A building has to be constructed on ground which has the following ground conditions:

Dimensions of the building=30m×20m and the depth of excavation is 10m (water table is at ground level)

Permeability of sand deposits below ground level =  $10^{-3}$  m/s.

The depth of water level has to be decreased by 2m below excavation level. In order to construct the building, dewatering has to be done by laying pumps at various junctions. Calculate the rate of flow of water when one pump is laid and compare it with the discharge when the number of pumps is increased.

The site conditions of the building is shown in figure (1).



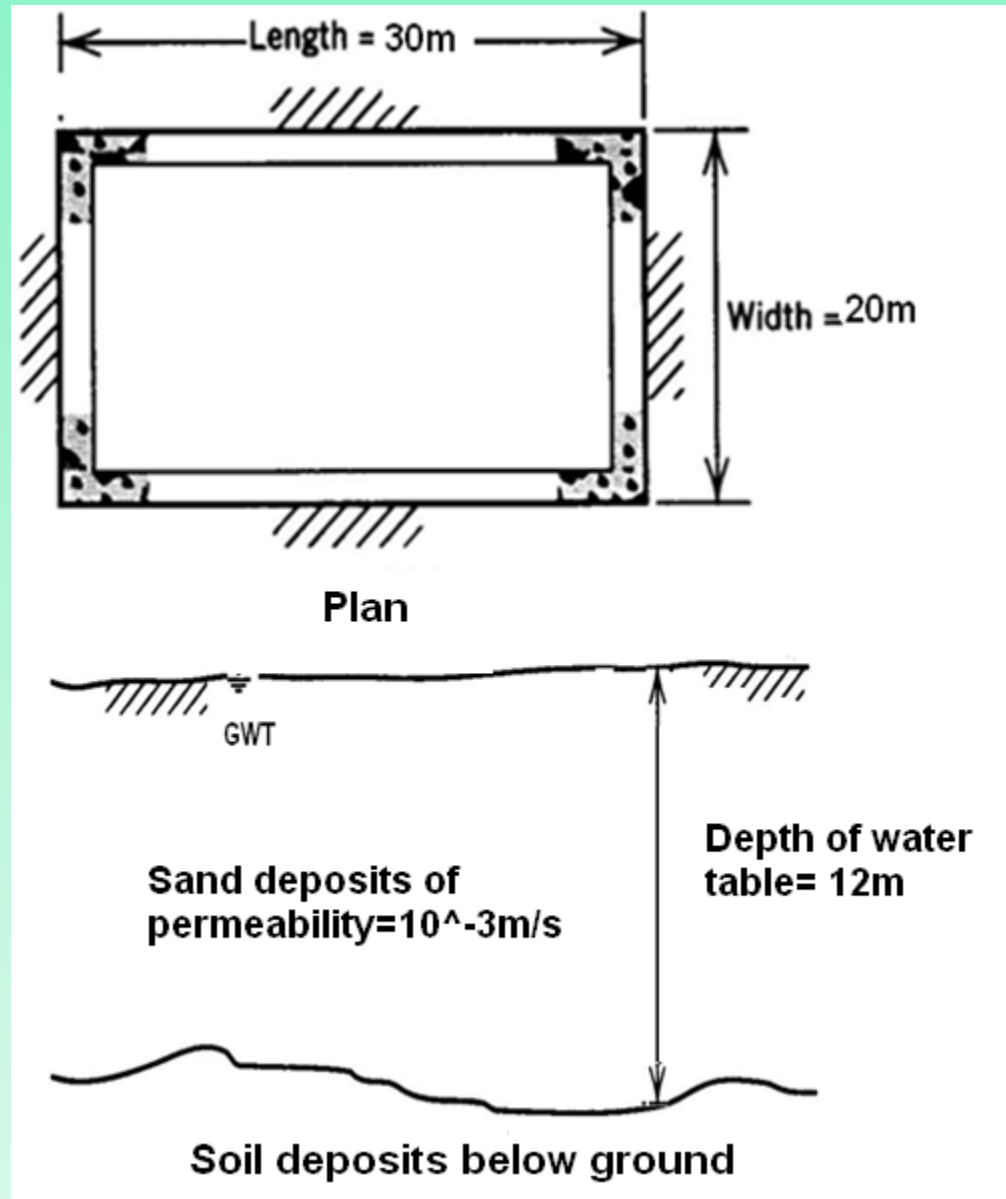

Figure (1)

Solution:

From the given data we know:

Permeability of the sand,  $k = 10^{-3}$  m/s

Depth of water level,  $h = 12$  m

Depth of drawdown = 2 m

In most of the cases, there is an empirical relationship to obtain an approximate value for the line of influence,  $L$  ( $=R$ ) and this is given by Sichardt:

$$L = C(h - h_w)\sqrt{k}$$

The value of constant  $C$  in meters when  $k$  is in meters /second are:

$C = 3000$  for wells

$= 1500$  to  $2000$  for single line wells (Mansur and Kaufmann)

Consider  $C=3000$

Hence,  $L = 3000 \cdot 2 \cdot (10^{-3})^{0.5} = 189.73\text{m}$

The formula for discharge is given by Forchheimer is:

$$Q = \frac{\pi k (H^2 - y^2)}{\ln L - \ln a}$$

Here  $H = 12\text{m}$ ,  $y = 10\text{m}$ ,  $L = 189.73$  and  $a = 7.8\text{m}$

$$Q = \frac{\pi k (12^2 - 10^2)}{\ln 189.73 - \ln 7.8} = 0.0433 \text{ m}^3/\text{s}$$

Expression for yield from a single well is given by

$$Q_{max} = 2\pi r h_0 \frac{\sqrt{k}}{15}$$

Substituting  $r = 0.1\text{m}$ ,  $h_0 = 2\text{m}$  and  $k = 10^{-3}\text{ m/s}$ , the yield for a single well is obtained as  $0.01\text{ m}^3/\text{s}$ . Hence, the number of wells can be taken as 5 to cater to the discharge of  $= 0.0433\text{ m}^3/\text{s}$ .

If the number of pumps are increased to more than one, the formula given by Forchheimer is:

$$Q = \frac{\pi k (h^2 - y^2)}{\ln L - \frac{1}{n} \ln x_1 x_2 x_3 \dots x_n}$$

Consider five pumps at different locations in and around the building at 10m respectively in different directions.

Now  $n=5$ ,

$x_1=10\text{m}$ ,  $x_2=10\text{m}$ ,  $x_3=10\text{m}$ ,  $x_4=10\text{m}$  and  $x_5 =10\text{m}$

$$Q = \frac{\pi * 10^{-3} * (12^2 - 10^2)}{\ln 189.73 - \frac{1}{4} \ln (10^5)} = 0.058\text{m}^3/\text{s} .$$

Hence five number of pumps will be able to cater to the discharge with adequate margin of safety.

## **Concluding remarks**

Dewatering techniques need considerable practical experience and many of the terms and parameters in the formula have uncertainties and variability. Hence trials are useful to confirm if the design is going to work in a satisfactory manner.