

Q.1 Which welding technique you would adopt to weld the vertical seams of two blocks of a ultra large crude carrier. Explain the salient features of the method.

Ans.

To weld the vertical seams of two blocks of ultra large crude carrier, we need a technique which can weld thick plates. Therefore we use Electroslag Welding.

Electroslag welding is a resistance welding method. Here the heat comes from the joule heating due to the electrical resistance of the slag.

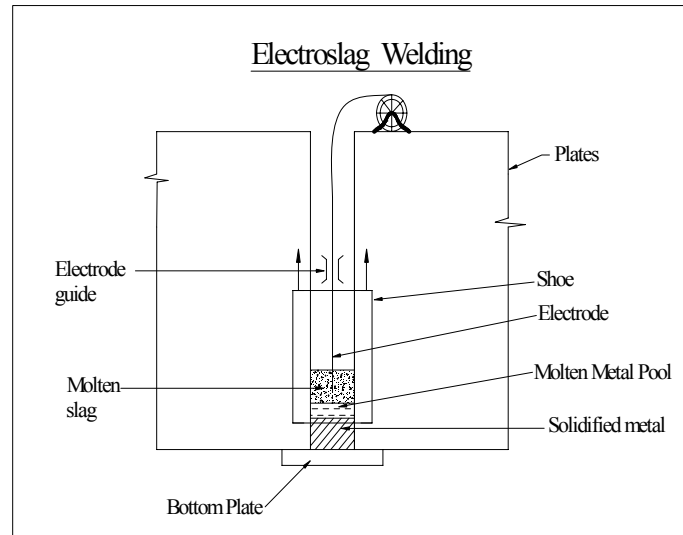

The salient features are:

- i) It is a method by which thick plates are welded in a single run.
- ii) Two shoes are provided which move upwards as the welding continues containing the molten metal pool as well as the molten slag. Contact surfaces of the shoes are shaped concave. It provides for the required amount of reinforcement on the weld deposit.
- iii) The electrode is kept immersed in the molten slag and it provides the filler metal.
- iv) There is no electric arc.
- v) Solidification of molten metal takes place from the bottom upwards at a slow rate. Angle at which the grains meet in the centre is determined by the shape of the molten weld pool. Weld pool shape is expressed by a "form factor".
- vi) Form factor is the ratio of the weld pool width to its maximum depth. Width is the root opening plus the total penetration into the base metal. Depth is the distance from the top of the molten weld pool to the lowest level of the liquid-solid interface.
- vii) The weld quality depends on the form factor.

- viii) Welding voltage is an extremely important variable. It has a major effect on depth of fusion and stable operation of the process. Increasing the voltage increases the sideways depth of fusion in the base metal. This leads to increase in the width of the weld pool increasing the form factor which in turn increases resistance to cracking.
- ix) For stable operation it is generally in the range of 32-55V. Too high a voltage may lead to slag spatter and arcing on top of the slag bath. Whereas too low a voltage may cause short circuiting and/or arcing to the weld pool. With thicker sections, higher voltages are used.
- x) Increasing welding current leads to increased heat input causing increased depth of molten weld pool. Thus it decreases the form factor lowering the resistance to cracking.
- xi) Generally currents of 500 to 700 A are used with 3.2 mm electrode.
- xii) Two types of electroslag welding, (a) non-consumable electrode guide cum contact tube and (b) Consumable guide extending down to the molten slag.
- xiii) The nonconsumable guide prevents the electrode from touching the plate sides and short circuiting.
- xiv) A minimum slag bath depth is necessary to ensure electrode immersion and melting beneath the surface.
- xv) Optimum slag bath depth is about 40 mm.
- xvi) Root opening should be enough to provide clearance for the guide tube and its insulation. For sufficient slag bath size and good slag circulation, a minimum root opening is required. Increased root opening increases the weld width hence the form factor.

Excessive root opening requires extra amount of filler metal which may become uneconomical. Also it may give rise to lack of edge fusion. Generally 20 to 40 mm of root opening is used.

For long welds, the root opening at the top of the joint should be about 3 to 6 mm more than that at the bottom to allow for closure of root opening due to shrinkage.

- (xvii) Low flux consumption about 1 kg of flux consumed for each 20 kg of weld metal.
- (xviii) Minimum distortion and no angular distortion.
- xvii) In this only vertical welding is done.

Q.2 Explain the most efficient method of mill scale removal.

Ans.

The most efficient method of mill scale removal is by Shot Blasting Method

After the steel plates are straightened and residual stresses are removed by passing it through the rollers as shown below, they are fed through the shot blasting chamber to remove the mill scale.

In this chamber, small shots of hard material are used to remove the mill scale. These shots strike the steel plate at an angle with high velocity. As a result it chips off a part of the scale. As shown in the figure, shots are fired on both top and bottom surfaces of the plate, while the plate keeps moving, thus removing the mill scale completely.

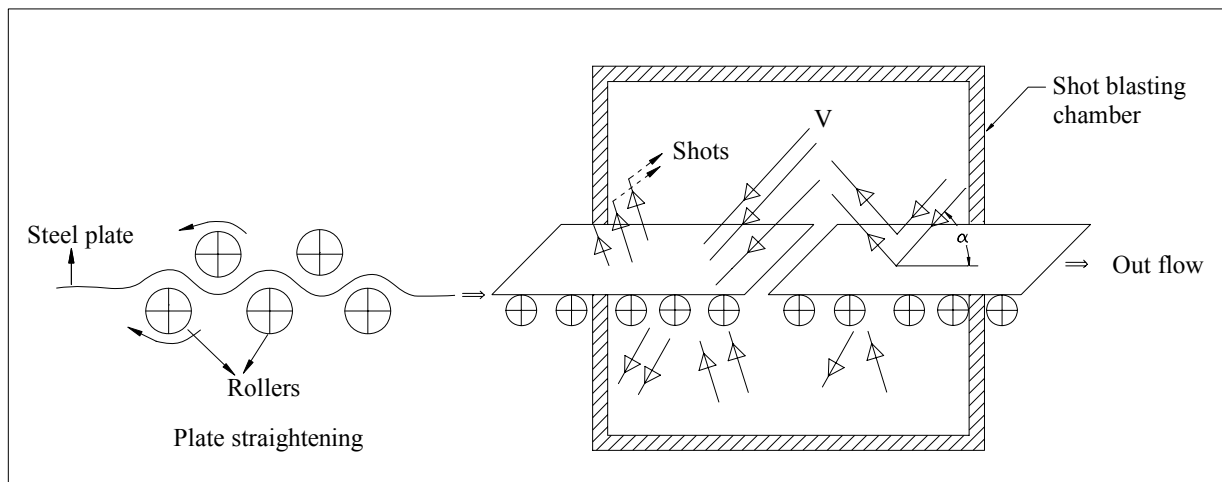

The process depends on the following parameters :

- i) Velocity (v) of the shots.
- ii) Angle (α) at which the shots strike the plate.
- iii) Size of the shot
- iv) Weight of the shot
- v) Feed speed of the plate, that is, the speed at which the plate is being moved.

The efficiency of this process is given by m^2/hr . The following are the advantages and disadvantages of this process.

Advantages:

- i) By setting the process parameters suitably the mill scale can be completely removed (100% removal).

- ii) The complete process is carried in a noise and dust insulated chamber and hence there will be no heavy dust and noise pollution which is produced as a result of the shots striking the plate.
- iii) The efficiency of this process is generally very high about 100 to 200 m²/hr.

Disadvantages:

- i) Lesser thickness plates upto 6 mm may get deformed.
- ii) When the shots strike the plate, locally the stress may exceed the yield stress at that point of the plate leading to work hardening. As a result the reserve plasticity decreases and may lead to formation of cracks.
- iii) Depending on the process parameters the shots may chip off part of the metal along with the mill scale (or) may not remove the mill scale completely. So to avoid these problems, the parameters have to be adjusted suitably.

Q.3 Why friction stir welding is referred to as solid state welding? What are the fundamental advantages one derives from FSW.

Ans.

Friction stir welding is referred to as solid state welding because:

- i) It does not lead to any melting of base metal i.e. no fusion zone is formed.
- ii) The friction between the FSW tool and the base metal leads to heat generation. It increases the temperature of base metal below the friction zone to about 80% of its melting point.
- iii) Therefore, all the components involved remain in solid state. Hence, it is called solid state welding.

Fundamental advantage of friction stir welding is that since it does not involve any melting of base metal, all the defects related to fusion welding are eliminated, such as,

- i) lack of deposition,
- ii) lack of fusion,
- iii) porosity,
- iv) slag inclusion,
- v) both hot and cold cracking.

Other advantages are, friction stir welding does not require any kind of shielding medium to protect the material from atmospheric oxidation as compared to other fusion welding processes at the same time it does not require any filler metal as well as edge beveling for butt joints. Complete through thickness welding is in a single pass. In case of welding of aluminum alloys removal of surface oxide layer near the weld zone is also not required.

Q.4 Explain how changing welding sequence can lead to significant change in weld induced distortion in fabrication of flat stiffened panels.

Ans.

The arrows in the following figures indicate the welding sequence followed for welding of the stiffeners. Three different cases of welding sequence have been studied.

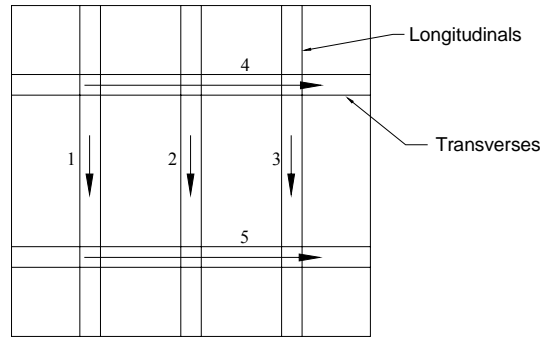

In case 1, the welding sequence followed is that of welding of longitudinals starting from one end of the plate and continuing to the other end followed by welding of transverses. The welding direction and the sequence of welding is indicated by the arrows and the numbers respectively.

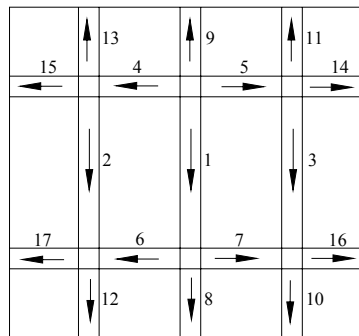

In case 2, the welding was carried out starting from the central longitudinal followed by the side longitudinal from one transverse to the other. Subsequently the welding of the transverses was carried out again from the central position moving outwards. Here first the longitudinals were welded followed by the transverses. It thus gave a more even distribution of stiffening of the plate and balancing of stresses due to welding as compared to the Case 1.

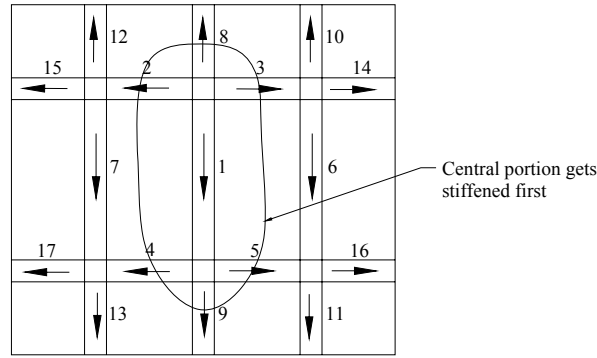

CASE 3

In case 3, the central longitudinal was welded first followed by the top and bottom transverses starting from the centre moving outwards as shown in the figure. This sequence of welding resulted in progressive stiffening of the plate strating from centre moving outwards. At the same time it further enhanced balancing of stresses caused by welding as compared to that of Case 2. As a result one finds that the resulting distortions are maximum in Case 1 where the stresses developed due to welding were left fully unbalanced. As expected a significant drop in distortion was observed in case 2. Whereas distortion was minimum in Case 3 as can be seen from the figure below obtained from FE analysis carried out for these 3 Cases of welding sequence.

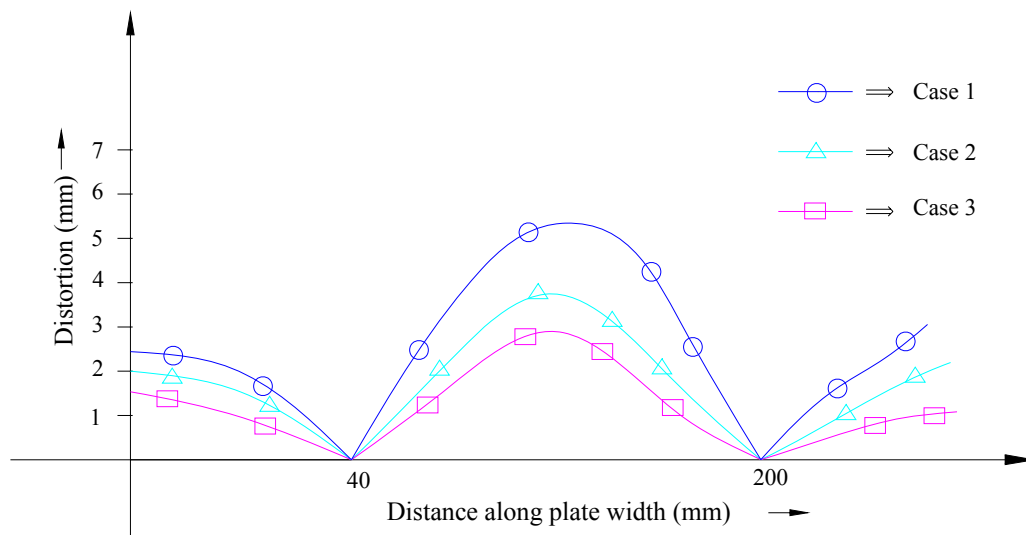

Q.5 For a very precise deposition of weld metal, say a 3mm fillet, what welding method and power source will be best suited – explain.

Ans.

For very precise deposition of weld metal, GMAW (gas metal arc welding) with pulsed current power source will be best suited.

In gas metal arc welding, the arc and the weld pool is shielded by an inert gas. For depositing a 3mm fillet in this process welding electrode of diameter 1.2 to 1.4 mm can be used. With a suitable low welding current the metal deposition can be precisely controlled. The metal deposition can be further controlled by using pulsed current power supply.

In pulsed current power supply, unlike continuous power supply, the power delivery takes place in predefined pulses as shown schematically in the following figure.

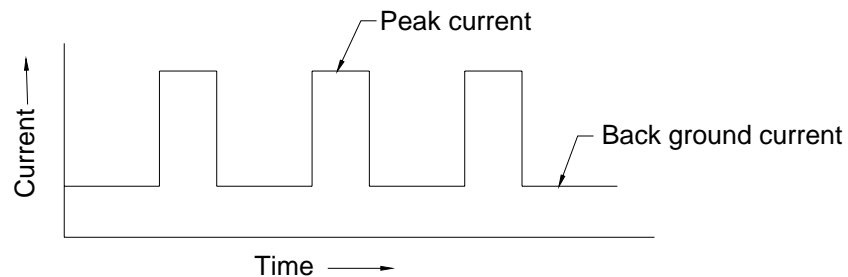

Pulsed power source

The total heat input is less in this mode of power supply. Metal transfer takes place during the peak current cycle and the back ground current maintains the arc. Thus the number of droplets getting detached and transferred to the weld pool can be controlled by the number of pulses of peak current per second. The peak current should be above the transition current if the transfer mode is that of spray transfer. The back ground current should be such that the arc does not get extinguished. Through this method precise deposition is achieved.

Q.6 Mention at least 4 different methods of plate cutting techniques. Explain the one that would be the most effective method for cutting aluminum plates.

Ans.

The various methods for plate cutting that may be used in shipbuilding are as follows:

- i) Mechanical
- ii) Oxy-acetylene
- iii) Plasma jet
- iv) Water jet
- v) Laser beam

Of these the first four methods are generally used. The laser beam cutting is feasible process however it works out to be an extremely expensive method and may not turn out to be viable in shipbuilding environment.

In case of aluminum, plasma jet cutting would be most effective. Aluminum is a highly active material and forms Al_2O_3 on its surface through natural exposure in air. The melting point of Al_2O_3 is much higher than that of aluminum. It is about 2500°C whereas that of aluminum alloy is about 600°C . At the same time the thermal conductivity of aluminum is very high. Hence if oxyacetylene cutting is tried the metal inside the surface layer of Al_2O_3 will attain its melting temperature very quickly, leaving the surface intact. In the process it will result in excessive deformation of the plate without achieving cutting of the plate. For effective cutting using oxyacetylene flame the melting temperature of the metal being cut should be less than that of the metal itself. Hence aluminum alloys can not be cut using oxyacetylene flame.

Hence a method that can produce an intense heat and can instantaneously raise the temperature of the plate much beyond the melting temperature of the refractory oxide Al_2O_3 should be chosen to cut aluminum alloys plates. This can be achieved with plasma jet cutting process.

In this method a plasma jet is created using an inert gas passing through a suitably designed nozzle. The inert gas or even compressed air is blown through a nozzle having an electrode in it. To initiate the plasma jet, an arc is first struck between the electrode and the nozzle by using a high frequency current. As the gas passes through this it gets ionized and the plasma jet is established. Once it forms the high frequency current is switched to the normal power supply sufficient to maintain the plasma column ignited.

The plasma thus produced has adequate kinetic energy as well as heat to melt the metal along with the refractory oxide layer instantaneously and blows off the molten metal away resulting in a narrow and smooth cut.

Q.7 Explain the mechanism behind weld induced angular distortion. Mention the other modes of distortions encountered during fabrication of stiffened plate panels.

Ans.

The angular distortion in the welding of plates arises basically due to the bending moment caused by the shrinkage forces resulting from temperature gradient that forms across the plate thickness. When welding is done the material near the fusion zone tries to expand. But the far away regions being cold resist this expansion.

Thus shrinkage forces develop. At the same time the heat flow from the welding arc causes temperature rise in the plates. This temperature rise is not uniform. Maximum temperature rise takes place at the plate top surface and minimum at the plate bottom surface, thus leading to a temperature gradient across the plate thickness. This causes gradually decreasing shrinkage forces to develop along the plate thickness as shown below resulting in a bending moment transverse to the welding direction on the plates being welded.

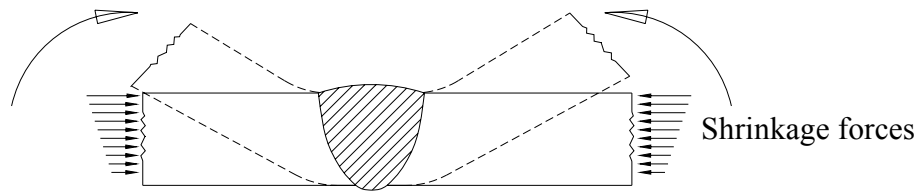

Other mode of distortion encountered during fabrication of stiffened plate panels is buckling of plate panel.

The severe temperature gradients due to welding produce thermo-mechanical coupling. This causes thermal expansion and shrinkage. These high stress levels at the weld zone produce plastic deformations. These plastic deformations lead to residual stresses. At the weld region the residual stresses are of tensile nature having magnitude almost equal to that of yield stress. Self equilibrating compressive residual stresses develop in the rest of the part of the plate away from the tensile zone. When these compressive stresses on the panel exceed the critical buckling stress of the panel, buckling occurs.

This type of buckling deformation may be observed during fabrication of stiffened plate panels as shown in the figure below:

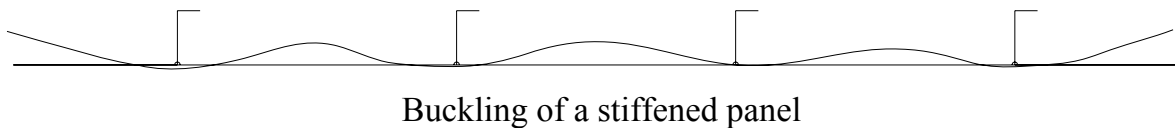

Q.8 Explain the possible methods of distortion mitigation through alteration of heating flow pattern.

Ans.

Distortion Mitigation methods through alteration of heat flow pattern.

i) Side heating:

In this method simultaneous heating of the plates away from the butt line is carried out on both sides of the welding torch as shown below.

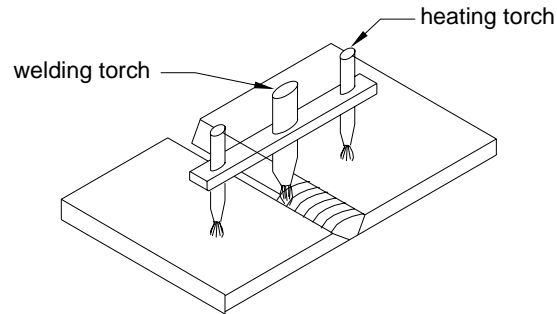

Welding with simultaneous side heating

This simultaneous side heating alters the heat flow pattern in the plates causing additional thermal stresses to develop which counteract those produced by welding.

This technique helps in reducing the opening of the finishing ends of the plates by altering the thermal pattern in the weldment during welding. Two flame heating torches are mounted on a frame with the welding head so that the side heating system can be moved along with the welding arc. The position of the heating torches relative to the welding head can be adjusted in the three x, y, z directions in order to control the side heating procedure. This system is mainly used for controlling the joint mismatch due to rotational distortion and thus can eliminate the necessity of tack welding.

The most desirable side heating is to heat wide regions away from the weld to moderate temperatures around 90°C-100°C to accomplish the following:

- The side heating should produce thermal stresses large enough to counteract those produced by welding.
- The side heating should not produce additional residual stresses.

ii) Heat Sinking:

Another means of altering the heating pattern is to remove heat quickly from the welded region so that it does not get spread in the plates away from the weld zone. Therefore by keeping the base metal cool, the modulus of elasticity and yield strength of the base metal is not lowered and thus the residual stresses and distortion are reduced. A schematic representation of heat sinking through water cooling below the plate surface undergoing welding is shown in the Fig. below:

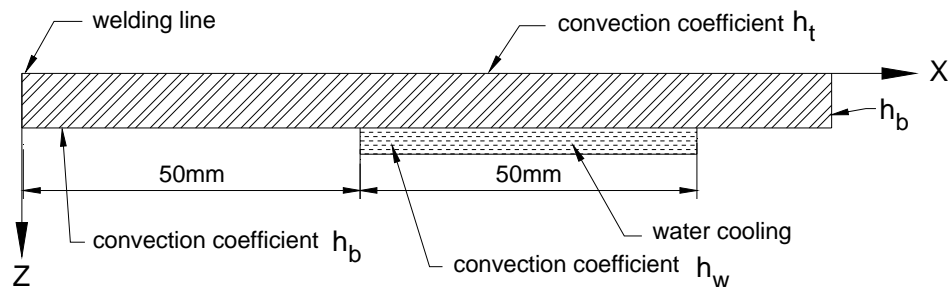

Schematic representation of heat sinking

The metallurgical consequences that are associated with changes in the temperature gradients and cooling rates must be accounted for in practical situations.

iii) Thermal tensioning

Thermal tensioning is nothing but simulating the mechanical tensioning situation by subjecting the panel to appropriate thermal cycles. Thus thermal tensioning is a more convenient means of achieving the force levels to prevent buckling caused by the welding of the longitudinal stiffeners. The concept is illustrated in the Fig. below:

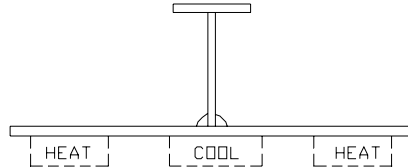

In this the heating pattern is altered by applying heat on both sides of a welded joint while the weld joint is cooled. If a temperature difference of about 170°C is generated, then the difference in expansion and contraction of the plate will create a tensile stress in the weld joint which is sufficient to prevent buckling.

Q.9 Explain the method of plate bending that can be automated. What difficulties one may encounter in automating a plate bending operation?

Ans.

Plate bending using universal press can be automated.

- i) In this method two arrays of hydraulic jacks are used, one at the ground and the other hanging from top. In this system of jacks, each jack can be operated independently. In this method the array of these jacks form the male and female dies as shown in the Fig. below.
- ii) The curved shape of the plate is first generated on the bottom array of jacks.
- iii) The plate to be bent is kept over this surface and pressed by the upper array of jacks.
- iv) Under this pressure the stress level exceeds the yield stress of the plates leading to bending of the plates.
- v) Thus almost any curved shape as relevant in shipbuilding can be achieved through this method.

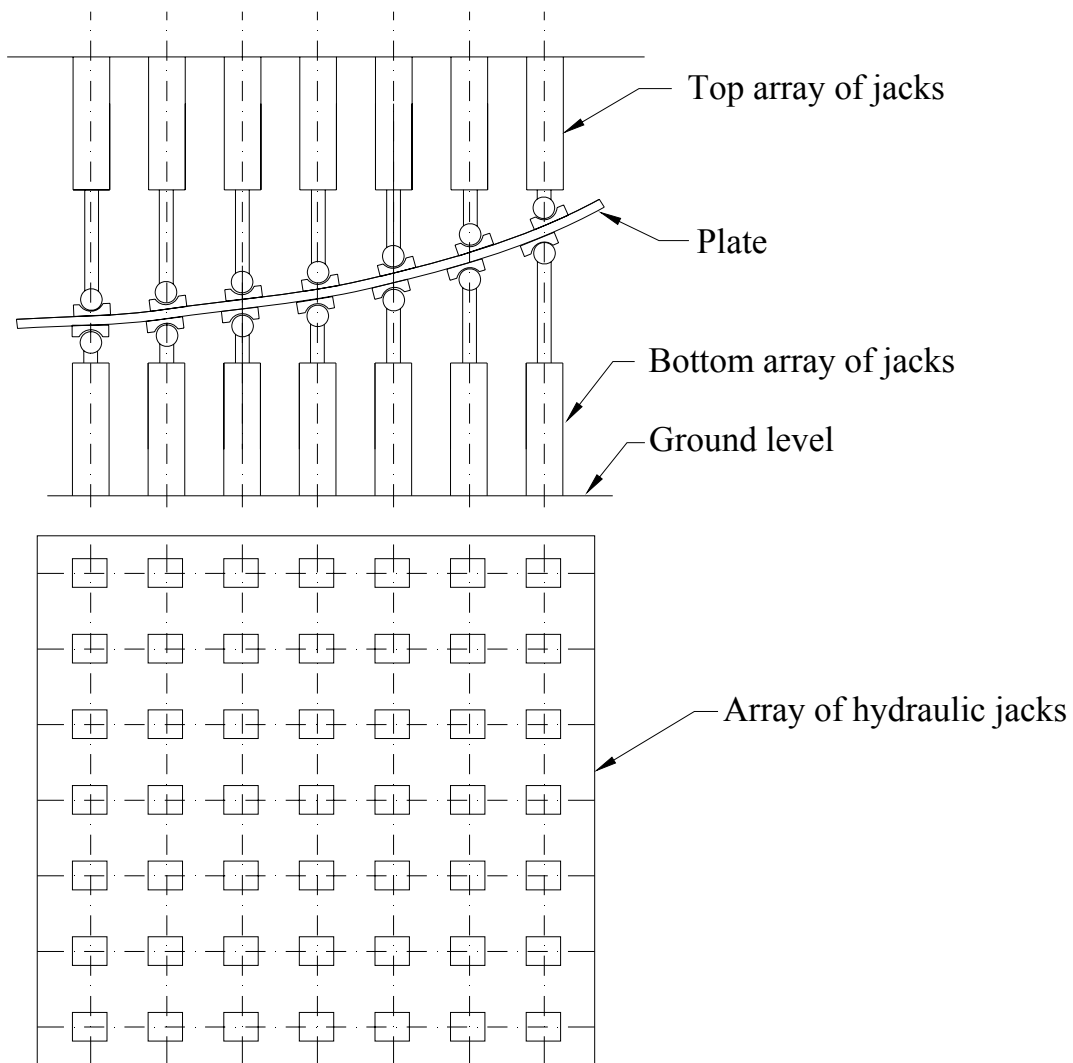

Schematic presentation of Universal Press

Difficulties in this process of automatic plate bending:

When pressure applied by jacks is removed the bent shape deviates from the shape under pressure. It is known as spring back action. The extent of spring back that may take place depends on mechanical properties of the given plate, i.e. yield stress and modulus of elasticity. Now these values are not unique for a given plate. They generally lie within a range. Hence exact amount of spring back can not be calculated. Hence in this process getting the exact bent shape will require monitoring of the plate shape after each stroke and evaluating the difference with that of the required shape and again apply the bending stroke. Thus it may require several strokes to finally get the desired bent shape.

Q.10 How structural compensations are done in case of unavoidable openings in a ship hull structure. Explain with suitable sketches.

Ans.

There are various unavoidable openings in a ship's structure for different functional requirements. Structural discontinuity caused by these openings may lead to local stress concentrations as well as loss of structural strength. Hence appropriate structural measures should be taken to compensate for these discontinuities.

i) Welding flat bar

In case of medium sized openings like doors, where the opening may cut through a stiffener, additional flat bar stiffeners are used to properly terminate the cut stiffener as well as a flat bar is welded all around the opening as shown in the Fig. below.

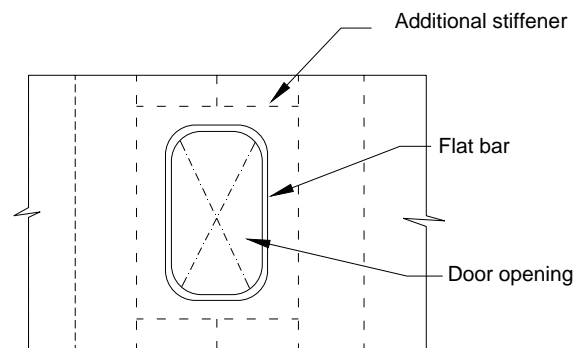

ii) Doubler plate

In case of small openings like various discharge openings on shell side, doubler plate is welded on the inner side of the shell plate as shown below.

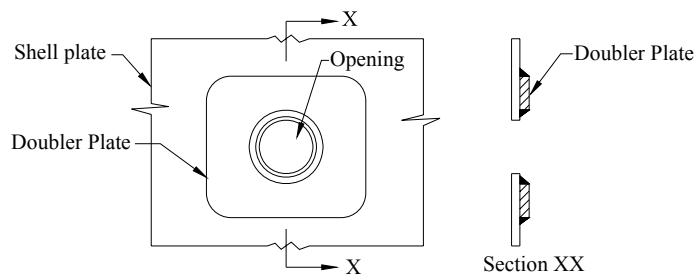

iii) Insert plate

In the areas of large openings as in case of cargo hatch opening, stress concentration is likely to occur at the corners of these openings because of sudden change in sectional area of the deck plate. Here plate of higher thickness compared to the adjacent plates is inserted at the corners and thus are referred to as insert plates. This is done to enable the

corner plates to withstand higher levels of stress because of inevitable stress concentrations.

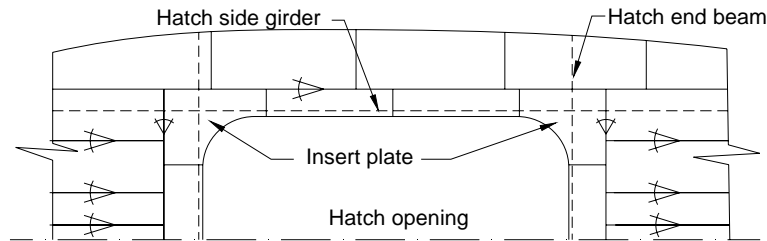

iv) Beams and Girders of higher scantlings

Stiffening members of higher scantlings in the form of hatch side girders and hatch end beams are used to make up for the lost strength due to large hatch opening as shown in the above Fig.

Q.11 What is understood by static and dynamic volt ampere characteristics of welding power supply. Explain their features.

The effectiveness of all welding power sources is determined by two kinds of operating characteristics, each of which affects welding performance differently. They are defined as static and dynamic characteristics.

Static characteristics

Static volt ampere output characteristics can be readily measured under steady state conditions by conventional test procedures using resistive loads. It is described by a set of output-voltage versus output-current characteristics curves. Based on this static volt ampere output characteristics welding power sources are divided into two types, Constant current and constant potential.

Constant Current (CC):

In this type of power source, also referred to as Drooping power source, variation in arc voltage causes a small change in current. It implies that small variations in arc length will not affect welding current, it will remain fairly constant. Thus heat generation almost remains constant leading to uniform metal deposition. A typical volt ampere characteristic curves of a CC power source are shown below.

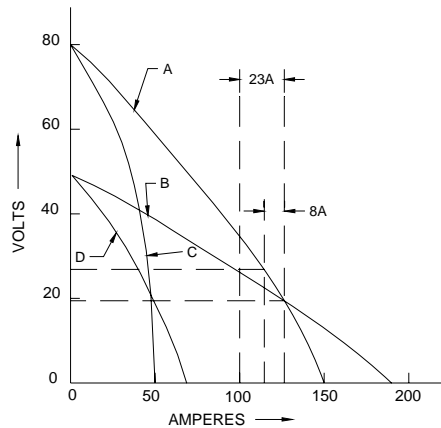

Typical volt-ampere characteristics of a “Drooping” power source

The curve-A indicates an open circuit voltage of 80V. An increase in arc voltage from 20V to 25 V i.e. for a 25% change, it would result in a decrease in current from 123 A to 115 A, i.e. 6.5%. The relative change in current is much smaller.

Therefore in case of SMAW, a small change in the arc length due to manual operation resulting in a change in arc voltage will lead to a much smaller change in welding current. The net effect is electrode melting rate remains fairly constant.

If the open circuit voltage is set at 50V (curve-B), for the same change of arc voltage, i.e. from 20V to 25V, the change in current would be from 123 A to 100 A, i.e. 19%, which is much higher than the previous case. Hence, a less skilled welder would prefer a power source with much steeper V-A curve, so that the current remains more or less constant even if there are fluctuations in arc length.

Constant Potential (CP):

Ideally the V-A curve of a CP power source should have been flat, i.e. parallel to current axis. However because of internal electrical impedance there is a minor drop in the output voltage with increasing current. This leads to a V-A curve with slight downward slope. A typical constant-voltage (constant-potential or Flat) power source has a negative slope of 1-2V/100A. This slope therefore can be changed by changing the internal impedance. A typical volt-ampere curve for a CP, also known as Flat power source is shown below.

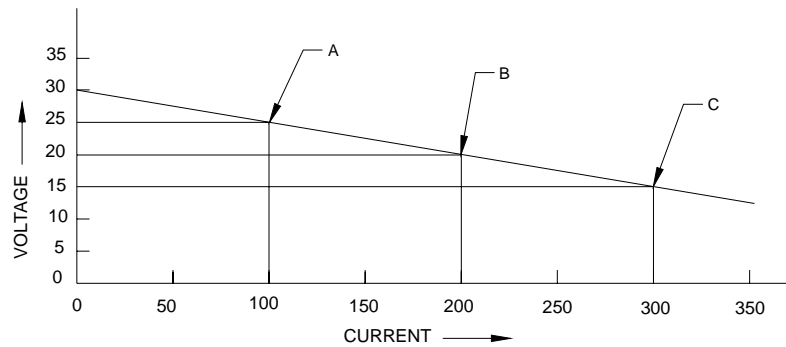

Typical volt-ampere characteristics of a “Flat” power source

A slight change in arc length will cause a substantial change in welding current. This will automatically increase or decrease the electrode melting rate to regain the desired arc length. This effect is known as self regulation.

Here with increase or decrease in arc voltage to A or C i.e. $\pm 5V$ or 25% change, it will produce a much larger change in current ($\pm 100A$ or 50%). Hence welding processes having constant electrode feeding mechanism, such as gas metal arc (GMAW), submerged arc (SAW) or flux cored arc (FCAW) maintaining constant arc length are suitable for CP power sources.

Dynamic characteristics

The dynamic characteristics of an arc welding power source is determined by measuring the transient variations in the output current and voltage that appear in the arc. These characteristics describe instantaneous variations. Their occurrence is very short of the order of 0.001 s. Welding arcs actually operate in changing conditions. In particular, transients occur for various reasons like, during the striking of an arc, during rapid changes in arc length, during the metal transfer across the arc and in case of AC welding during arc extinction and reignition in each half-cycle.

These arc transients can occur in 0.001 s, the time interval during which significant change in ionization of arc column occurs. The static volt-ampere characteristics have little significance in determining dynamic characteristics of an arc welding system. The dynamic characteristics of an arc welding power source are influenced by the following design features,

- local transient energy storage, such as DC series inductance or parallel capacitance circuits,
- feedback controls in automatically regulated systems,
- modifications of waveforms or circuit operating frequencies.

Controlling these characteristics will improve arc stability. Stable arc will provide uniformity of metal transfer, reduce spatter and weld pool turbulence.

Manufacturers of welding power supplies give the static volt-ampere characteristics, however there is no universally accepted method by which dynamic characteristics can be specified. A power supply with good dynamic characteristics will respond rapidly to these transients.

Q.12 What is a pulse mode power supply? In what situations it is beneficial to use such power supply for carrying out welding.

Ans.

Generally in electric arc welding the power sources deliver a continuous power, whereas the metal transfer from the electrode takes place intermittently. Hence continuous high current is not required. Thus the arc power can be reduced by designing the power supply in such a way that it will provide higher current only when metal transfer takes place.

The current level during the metal transfer interval is kept sufficiently low so as to avoid any metal transfer however it is maintained at a level high enough to sustain ionization in the arc region. This current is more commonly known as 'background current' which helps in keeping the arc alive. Whereas in the metal transfer interval, the current is raised above the transition current for sufficient time, enough to allow transfer of one or two droplets. This current is known as peak current or pulse current as shown below.

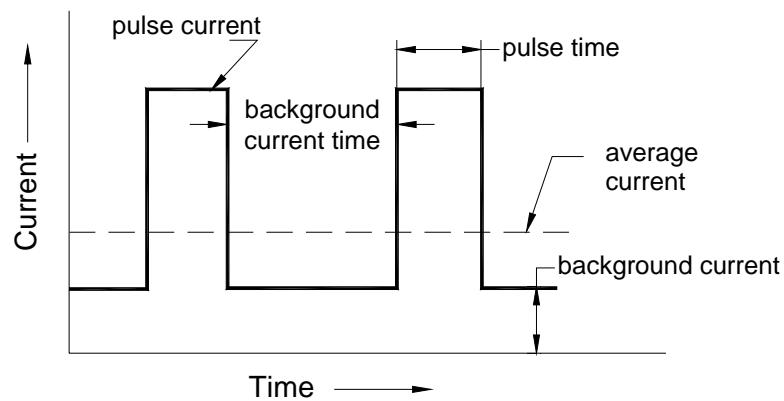

Current wave form of a pulsed power source

By controlling the pulse variables i.e. peak current, background current, peak current time and background current time, it is possible to have a control on metal transfer, allowing only single drops to transfer per pulse, while retaining the background current.

In situations like fillet welding of thinner plates where a very precision metal deposition is required pulsed power supply with GMAW can be used to weld in all positions. The heat input in this process being minimum the distortions can also be maintained at a minimum level.

- Q.13** (a) On what basis the structural arrangement of a ship is laid out? Explain the stiffening arrangement of the main deck of a general cargo carrier.
- (b) Mention the structural members contributing towards longitudinal and transverse strength of a bulk carrier.

Ans. (a)

The structural arrangement of a ship is laid out primarily on the basis of the type of cargo the ship will carry, i.e. whether it will carry bulk cargo, container, oil, passenger or wheeled cargo. The structural arrangement also depends on the framing system adopted for structural design.

Main Deck of a General Cargo Carrier

- 1) Main deck of a general cargo carrier has longitudinal framing system, i.e. primary stiffening members are longitudinal. This is because longitudinal framing system provides for higher buckling strength. This will result in higher strength to weight ratio. Deck longitudinals provide for longitudinal strength.
- 2) Deck transverses are transverse stiffening members of higher scantling which provide support to the deck longitudinal and also reduce their unsupported span. These members provide for transverse strength.
- 3) The space between the hatch opening, referred to as cross deck structure, is transversely stiffened. Since the length of this cross deck structure is much less than 15% of the length of the ship, this part does not contribute to longitudinal strength. Hence the deck plate used in this place in line of opening is of much smaller thickness compared to the plates outside line of opening. Therefore this part becomes prone to buckling due the action of compressive transverse loads. Therefore transverse stiffening is done on the cross deck
- 4) Hatch side girders and hatch end beams are provided around the hatch openings to partially compensate for the loss in strength due to large hatch opening.
- 5) Deck transverses are provided at about 3 to 4 frame space to provide support to the longitudinals as well as to provide for transverse strength.
- 6) Because of narrowing of the sections, the fore and aft end of the deck is stiffened by stiffeners laid out somewhat radially, know as cant beams.

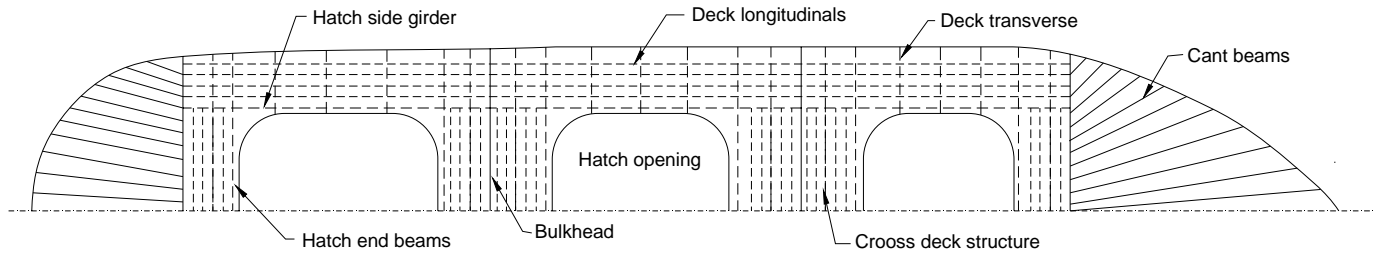

Structural arrangement of main deck

(b) The structural members contributing towards longitudinal and transverse strength of a ship are as follows:

Longitudinal strength members:

1. Main deck plating
2. Main deck longitudinal
3. Hatch side girder
4. Side shell plating
5. Tank top plating
6. Tank top longitudinal
7. Bottom shell plating
8. Bottom shell longitudinal
9. Centre girder
10. Side girder
11. Top and bottom wing tank sloping bulkheads
12. Wing tank longitudinals

Transverse strength members:

1. Transverse subdivision watertight bulkhead
2. Deck transverse
3. Side shell frame
4. Side shell web frame
5. Top and bottom wing tank transverse
6. Plate floor and water tight floor

Q.14 Write in brief the salient features of shot blasting and acid pickling process.

The salient features of shot blasting are:

The process involves removal of mill scale using tiny metal shots which are fired onto the metal surface from both sides. The shots impinge on the metal surface and are rebounded taking off the mill scale with it. The process is fully automated, plate feeding takes place using roller conveyor. The shots are recycled. The various control parameters are,

- Velocity of the shots
- Angle of shot impingement
- Size and mass of Shots
- Speed of feeding the plate

These parameters can be set appropriately to get the desired surface completely free from mill-scale achieving a surface finish Sa 2.5. The process can be automated, thus achieving a production rate of 100 m²/hr.

The shot blasting process is followed by a priming process. The primer used is rich in Zinc. The primed plate is dried in a drying chamber.

The disadvantages of the process are,

- With improper setting of shot blasting parameters it may result in work hardening of the metal surface thus reducing the reserve elasticity of the surface layer. It may result in formation of fine cracks on the surface.
- This process is not very suitable for thin plates. It can lead to the deformation of such plates.

The salient features of the acid pickling process are,

As the name suggests, an acid is used to dissolve the mill scale off the steel surface. The acid generally used is either HCl or H₂SO₄. Both have merits and demerits. Chloride salts have better solubility in water compared to sulphate salts, therefore salt removal is easier and HCl is preferred. Where as HCl is more volatile and more so at elevated temperature compared to H₂SO₄, therefore acid consumption is more in case of HCl. For effective pickling operation, adequate agitation of the acid bath is done.

After the acid bath, a water bath follows which removes the acid from the plates. It is then given an alkali wash, generally Ca(OH)₂, which removes all traces of acid from the plate. This operation yields a shining steel surface devoid of any mill scale. The plates are then passed through a passivising bath, composed of 23-25% Phosphoric acid with 19-20% Ethyl Alcohol. It reacts with the plate to form a uniform layer of insoluble inert salt. This passive layer prevents the plate from further corrosion or rust formation due to exposure to weather. This process can be easily automated to give higher productivity.

The various control parameters for this process are:

- Acid bath concentration
- Pickling time
- The temperature of the acid bath

The reaction rate increases with increasing temperature reducing pickling time. Pickling increases with decreasing acid concentration. Therefore these parameters are to be monitored and controlled to achieve proper pickling of plates. Improper parameters may lead to inadequate pickling or corrosion of the steel plates.

The advantages of this process are:

- No work hardening takes place (as in shot blasting)
- Thin plates are not deformed.
- The process is noise free.

The disadvantages are:

- Operations involving acids and alkalis are hazardous.
- It has a high water requirement.
- The acidic fumes which develop in the pickling hall can corrode the cranes and other equipment.

Thus, we see that both shot blasting and acid pickling are efficient ways of mill scale removal and are widely used in shipyards.

Q.15 How metal transfer takes place from electrode in case of electric arc welding.

Ans.

The principal metal transfer modes in an arc welding process are as follows:

- Short circuiting transfer
- Globular transfer
- Spray transfer

Number of factors influences the type of metal transfer in a GMAW process. The most influential of them are the following:

- Welding current, AC or DC and its magnitude
- Electrode wire diameter.
- Electrode composition
- Shielding gas

Short Circuiting Transfer

Short circuiting transfer mode is used for low current operation with lower electrode diameters. In short circuiting transfer, also called 'dip' transfer, the molten metal forming on the tip of the electrode wire is transferred by the wire dipping into the molten weld pool thus causing a momentary short circuit. Metal is therefore transferred only during a period when the electrode tip is in contact with the weld pool and no metal is transferred across the arc gap. This type of metal transfer mode produces a small, fast-freezing weld pool that is generally suited for joining thin sections, for out-of-position welding and for bridging large root openings.

The frequency of short circuiting, i.e. electrode dipping in molten pool varies from 20 to over 200 times per second. As the electrode wire touches the molten pool, short circuit takes place causing a sharp drop in arc voltage and rise in the welding current. The

sequence of events during a short circuiting metal transfer and the corresponding current and voltages are shown in the following Fig.

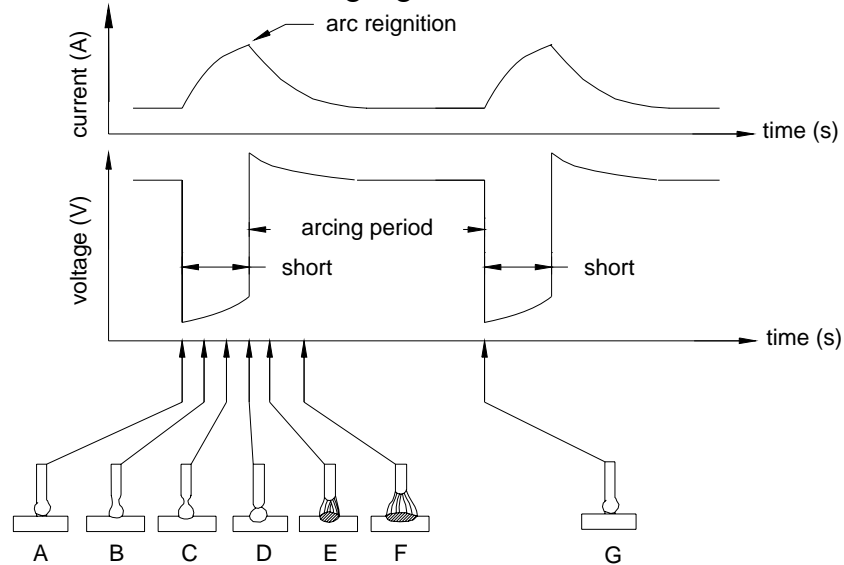

Schematic representation of short circuiting metal transfer

The molten droplet of the wire tip gets detached at D and E, initiating an arc as shown in E and F. The rate of current increase should be high enough to heat the electrode and promote metal transfer, at the same time it should be low enough so as to minimize spatter caused by violent separation of the molten droplet from the electrode tip.

As the arc is reestablished at E and as the electrode wire feed continues, the tip of the wire starts melting and gets short circuited at G and again the cycle of current increase and metal detachment starts. The open circuit voltage is kept low enough so as to ensure that the drop of molten metal at the wire tip does not detach until it touches the molten pool in the base metal.

Globular Transfer

Globular transfer is characterized by a drop size with a diameter greater than that of the electrode. The large drop is easily acted on by gravity, generally limiting successful transfer to the flat position. In this mode the metal transfer takes place in the form of globules at a rate less than 10 drops/s. If vertical welding is done with globular transfer, some of the molten-metal drops will never get to the weld. Globular transfer takes place with a positive electrode (DCRP/DCEP) when the current is relatively low regardless of the type of shielding gas.

At current levels only slightly higher than those used in short-circuiting transfer, globular axially-directed transfer can be achieved in a substantially inert gas shield.

At low arc voltages, i.e. with too short arc lengths, the molten droplet at the electrode tip grows in size and may even touch the workpiece causing a short circuit. The arc length

should therefore be long enough or in other words arc voltage should be high enough to ensure detachment of the droplet before it touches the weld pool on the job. However on welding with higher voltage may give rise to lack of fusion, insufficient penetration and excessive reinforcement thus rendering the weld unacceptable.

Spray Transfer

In this mode when the current exceeds a certain critical level known as transition point, metal transfer takes place in the form of fine droplets at a rate of about few hundred drops per second. These metal droplets are accelerated axially across the arc gap. Spray transfer is associated primarily with the use of inert gases. Either pure Argon or argon-rich with 0.5 to 5% oxygen shielding gas is used. With such gas mixtures a true spatter-free axial spray transfer becomes possible with DCRP (DCEP) power supply and with current above transition point.

The spray transfer yields a highly directed stream of metal droplets with substantial energy so as to have velocities which overcome the effects of gravity. Because of this, spray transfer mode can be used for welding in any position. The metal droplets being very small, short-circuit does not occur and hence spatter is virtually eliminated. The spray transfer welding is widely used and almost any metal or alloy can be welded because of the inert gas shielding. However, in this process there is a limiting thickness below which spray transfer can not be used unless the arc is pulsed. Spray transfer welding being a high current, high heat input process, it produces a deep penetration and therefore welding thin plates with this mode may become difficult. The resultant arc forces can cut through thin plates instead of welding them. It also produces high weld metal fluidity with a large weld pool too large to be supported by surface tension in vertical or overhead position, because of very high temperature of the molten weld metal. This high fluidity again makes it difficult to weld in overhead position. This disadvantage is overcome by using pulsed spray welding process.

Q.16 Mention the various process variables and their effects on weld profile in case of electric arc welding.

The various process variables in electric arc welding and their effects on weld profile are explained below:

(i) **Welding current:**

It is the most influential variable in a welding process. It controls the electrode melting rate and hence the deposition rate, the depth of penetration, and the amount of base metal melted. If the current is too high at a given welding speed, the depth of fusion or penetration will be too great. For thinner plates, it tends to melt through the metal being joined. It also leads to excessive melting of electrode resulting in excessive reinforcement. On the other hand, if the welding current is too low, it may result in lack of fusion or inadequate penetration. Too much current means more heat going inside parent metal, leading to more distortion and grain growth.

(ii) Arc Voltage:

Arc voltage depends on the arc length. If the arc length is increased there will be an increase in the arc resistance resulting in higher drop in voltage, or in other words the arc voltage will increase and the current will decrease.

The weld bead appearance depends on the arc voltage. An increase in arc voltage tends to flatten the weld bead, and increase the width of the fusion zone. Excessive high voltage may cause porosity, spatter and may lead to undercut. Reduction in arc voltage may cause narrower weld bead with a higher crown and deeper penetration. Hence trials are essential to obtain an optimum arc voltage. The arc voltage is varied within narrower limits than welding current.

(iii) Welding Speed:

Welding speed is the linear rate at which the arc moves along the weld joint. Welding speed is particularly important because it controls the actual welding time and hence it has a direct effect on the cost.

If welding speed is increased,

- Heat input per unit length of welded joint decreases.
- Less filler metal is deposited, resulting in lack of weld deposition and less weld reinforcement.
- Reduction in distortion and residual stress.
- There is a tendency for undercut and porosity, since the weld freezes quicker.
- It may result in bad bead shape (uneven deposition) due to instability in arc blow.

If welding speed is decreased,

- Filler metal deposition rate increases
- Heat input rate increases.
- Weld bead gets wider and more convex.
- Penetration decreases with further decrease in speed.
- Large molten pool resulting in a rough bead and possible slag inclusion.
- Heat-affected zone will increase in size as the cooling rate decreases.
- Residual stress & distortion will increase.
- Undercut and porosity will decrease

With all other welding parameters held constant, weld penetration attains a maximum at an intermediate speed of welding. For excessive slow welding speed when the arc strikes a rather larger molten pool, the penetrating force of the arc gets cushioned by the molten pool of metal. With excessive welding speed, there is a substantial drop in thermal energy per unit length of welded joint, resulting in undercutting along the edges of the weld bead because of insufficient deposition of filler metal to fill the path melted by the arc. Within limits the welding speed can be adjusted to control weld size depth of penetration.

(iv) Electrode Feed Speed

The electrode feed speed determines the amount of metal deposited per unit length of weld or metal deposited per unit time. Generally in all welding machines having auto

electrode feeding mechanism, the wire feed control is coupled with current control. Increasing electrode feed speed automatically increases the arc current and vice versa.

(v) Electrode Extension

The electrode extension is the distance between the end of the contact tube and the end of the electrode. An increase in the electrode extension will result in an increase of electrical resistance. This leads to resistance heating of the electrode between the contact tube and the arc. This gives rise to an additional heat generation and increases the electrode melting rate. Hence, the longer the extension, the greater is the heat generation thus reducing the power delivered to the arc. This reduces the arc voltage which in turn reduces the bead width as well as weld penetration.

At current densities over $125\text{A}/\text{mm}^2$, the electrode Extension becomes a significant variable. An increase of 25% to 50% in deposition rate can be achieved by using long electrode extensions without increasing the welding current. This increase in deposition rate is always accompanied by decrease in penetration. Therefore, when deep penetration is desired long electrode extension is not recommended. On the other hand in case of thinner material, when there is a possibility of melt-through, a longer electrode extension will be beneficial. However, as the electrode extension increases, it becomes more and more difficult to maintain the correct position of the electrode tip with respect to the joint to be welded.

vi) Electrode Diameter

The electrode diameter influences the weld bead configuration. It has a direct effect on weld penetration and deposition rate as can be seen in the following figure.

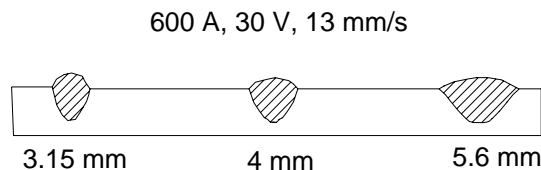

Effect of electrode size on weld bead shape and penetration

At any given current, a smaller diameter electrode will have a higher current density causing a higher deposition rate compared to an electrode of large diameter. Therefore a larger diameter electrode requires a higher minimum current than a thinner electrode to achieve the same metal transfer characteristics. Hence a higher diameter electrode will produce higher deposition rate at higher current. In case of poor fit-up, a larger diameter electrode is better than smaller ones for bridging large root openings.

vii) Electrode Polarity

When the electrode is connected to the positive pole, it is referred to as DCEP (direct current electrode positive) or DCRP (direct current reverse polarity). In DCEP, the direction of current flow is from the plate (-ve pole) to the electrode (+ve pole). This causes electrons to bombard on the electrode tip causing additional heating of the electrode. It results in extra melting of electrode causing increase in deposition rate.

Whereas when the electrode is connected to the negative pole, the vice versa happens leading to deeper penetration in the plate. Therefore when more melting of electrode is required, then electrode is made positive and when more fusion depth is required, then plate is made positive.

Q.17 Make a broad classification and mention the various welding processes used in shipbuilding industry. Explain the welding process which is most suitable to carry out high deposition down hand welding.

Welding process can be broadly classified under two heads (i) Fusion welding and (ii) Solid state welding. Under solid state welding we have Friction Stir Welding and under Fusion Welding, the following are widely used in shipbuilding industry:

- i) Shielded Metal Arc welding
- ii) Gas Metal Arc Welding (GMAW)
- iii) Submerged Arc Welding (SAW)
- iv) Electroslag welding
- v) Electrogas welding

Submerged arc welding (SAW) is the most suitable down hand high deposition welding process. Submerged arc welding involves formation of an arc between a continuously-fed bare wire electrode and the work-piece. The process uses a flux to generate protective gas and slag, and also helps to control the composition of the deposited metal by providing alloying elements to the weld pool. Prior to welding a thin layer of flux powder is placed on the work-piece surface. The arc moves along the joint line with the arc fully submerged in flux. As the arc is completely covered by the flux layer, heat loss is minimum. This provides a thermal efficiency as high as 80-90%. It produces no visible arc light, welding is spatter free and there is no need for fume extraction. The flux, apart from shielding the arc and the molten pool from atmospheric contamination, plays the following roles:

- The stability of the arc is dependent on the flux.
- Chemical and thus the mechanical properties of the weld metal can be controlled by suitably choosing flux composition
- The quality of the weld may be affected by the quality and quantity of the flux used over the arc.

Q.18 Explain what framing system is preferable for stiffening of main deck, side shell and double bottom of a 120 m long general cargo carrier.

Main Deck of general cargo carrier:

Longitudinal framing system is preferable for stiffening of the main deck of a general cargo carrier. The longitudinals run along the length of the ship from aft collision bulkhead to the forward collision bulkhead. This is done for the deck plating outside the line of opening. Whereas within the line of hatch opening, i.e. between the hatch side girders,

the deck plating is stiffened by transverse beams. This part is known as cross deck structure. At the ends of hatch opening hatch side girders and at the ends hatch end beams are provided. The deck longitudinals are supported by deck transverses at intervals of about 3 to 4 frame space. The fore and aft part of the deck plate is stiffened by cant beams. A typical stiffening arrangement is shown in the following figure.

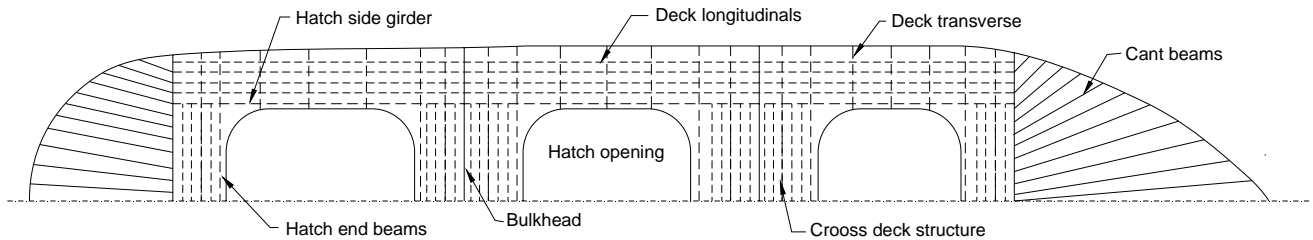

Stiffening arrangement of main deck of a general cargo carrier

Side Shell:

Transverse framing system is adopted for stiffening of side shell of a general cargo carrier. Though longitudinal framing system provides for better buckling strength and thus gives higher strength to weight ratio, still transverse system is adopted here. If longitudinal framing system is used then it would require transverse web frames having web depth at least double to that of the longitudinals. In that case it would have encroached more in the cargo stowage space. Whereas with transverse framing the web depth of transverse web frames will be smaller than that in longitudinal framing system. Hence one will achieve higher cargo stowage space.

Double bottom:

For reasons already mentioned above, the double bottom space is again stiffened using longitudinal framing system. It will have centre keelson and side girders port and starboard. The inner bottom and bottom longitudinals will be supported by plate floors at intervals of 3 to 4 frame space as in that of the deck transverses. A typical double bottom unit is shown in the figure below:

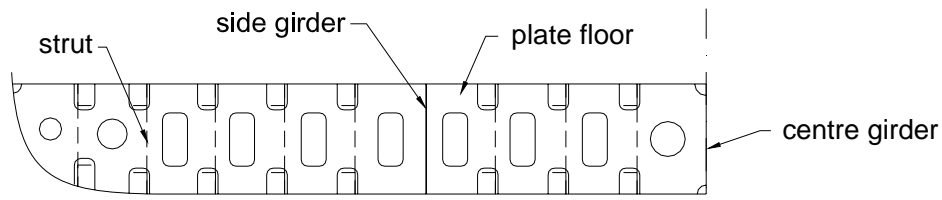

A typical double bottom unit with longitudinal framing system

Q.19 Discuss the various strength aspects those are to be looked into while designing the structural arrangement of a ship.

While designing the structural arrangement of a ship the following strength aspects are to be kept in mind.

- i) Longitudinal strength.
- ii) Transverse strength.
- iii) Torsional strength.
- iv) Local strength.
- v) Strength/Weight ratio.

Longitudinal Strength:

Ships, specially the ocean going ones are somewhat slender structure, i.e. it has a length to breadth ratio varying from about 3 to 6. Hence the longitudinal strength aspect becomes very important. Due to the difference in the load and buoyancy distribution along the length, a ship experiences a longitudinal bending moment with its maximum at around midship region. This causes tensile and compressive stresses in the hull girder. The deck and the keel plate being furthest away from the neutral axis, they experience maximum stress. Hence to avoid buckling or tensile failure it is always preferable to have longitudinal framing system in the deck as well as in the double bottom.

Transverse Strength:

Due to external loads e.g. resulting from ships encountering oblique waves, The ship's hull is subjected to transverse loading. If the hull structure is inadequately strengthened for transverse strength, these transverse loads may cause deformation in transverse direction known as 'Raking'. To address this problem and to provide adequate transverse strength, adequate transverse stiffening members are provided. The structural members which contribute towards transverse strength are transverse water tight bulkheads, deck transverses, side shell transverse frames in case of transverse framing system and floors in double bottom.

Torsional strength.

The problem of torsional strength needs to be addressed seriously in case of container ships where deck openings are very large in comparison to the breadth of the vessels. It is almost a case of open deck ship. Unless adequate stiffening is done the ships may undergo torsional deformation leading to loss directional stability. This is taken care of by providing box girder or by adopting double walled, i.e. cellular construction. This problem becomes more critical as the size of the vessel increases. However for other ships having smaller deck openings no deck opening as in case of crude carriers torsional strength aspect is not as serious because the transverse stiffening automatically provides for adequate torsional strength.

Local Strength

Local strength requirement assumes significance in the areas where the hull structure is subjected to localized loading like in the case of support bearings of propeller shaft,

support structure for rudder stock, derrick and crane foundation on the deck, forward end structure subjected to slamming load, forward most deck plating subjected to load due shipping in of green waters, etc. Local strengthening is done by providing additional stiffening members like stringers in the side shell and centre line wash bulkhead in the ford end construction, cant beams in the forward part of deck plating, plate floors at every frame space in engine room, increased scantlings and additional stiffeners in way of seatings of deck machineries, etc.

Strength to Weight Ratio

While deciding and laying out a structural arrangement the strength to weight ratio aspect must be kept into mind. A good design will provide for high strength to weight ratio, e.g. frame spacing should be so chosen that for the required strength the weight of the structure works out to be minimum.

Q.20 Make a neat sketch of a double bottom structure of a general cargo carrier and mention the various structural members in it.

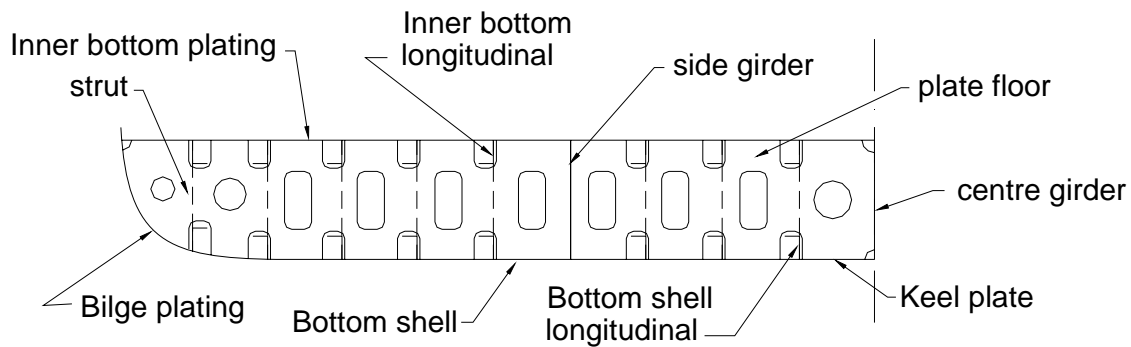

Double bottom structure with longitudinal framing system
in way of plate floor of a general cargo carrier

Q.21 Mention the sequence of production activities carried out from steel stockyard to the stage of fabrication of subassemblies in a shipyard. Why it is recommended to remove mill scale from the steel plates used for fabrication of ship.

The sequence of production activities carried out from steel stockyard to the stage of fabrication of subassemblies is shown schematically in the figure below:

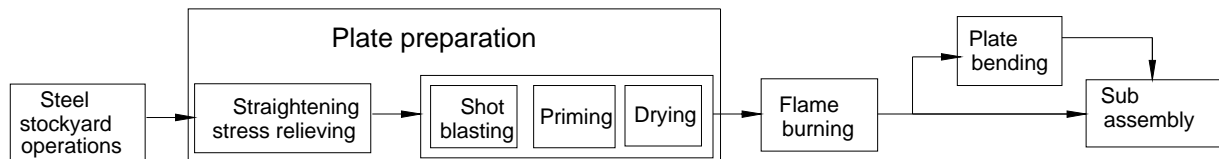

Sequence of plate fabrication activities

It is recommended to remove mill scale from steel plates to be used for fabrication of ships, primarily because of the following reasons:

- i) Mill scale is a layer of ferric and ferrous oxides formed on the plate surface during the hot rolling operation of the steel plates in steel rolling mills. Initially the bondage of this layer with the steel surface remains very strong. However with passage of time it becomes weaker. On exposure to normal atmospheric conditions in about 6 months time the layer of mill scale start peeling off of its own, thus exposing the bare steel surface. Hence if steel plates are used without removing the mill scale and the hull surface is painted for corrosion protection, over a period of time the mill scale along with the paint film peels off and the plate surface gets exposed to corrosive environment.
- ii) If mill scale is not removed prior to subsequent fabrication processes, it may interfere with cutting and welding operations. Defects in weld deposit may occur due to contamination from mill scale as well as it may cause hydrogen diffusion in the steel microstructure leading to hydrogen embrittlement. The source of hydrogen being from the hydroxides likely to be present in the mill scale.

Q.22 What are the basic characteristics of shipbuilding industry and explain how it is different from other manufacturing industries.

Shipbuilding industry has distinctly different characteristics compared to that of other manufacturing industries. These can be summerised as follows:

- i) Size of the product – The size of the products of shipbuilding industry like ocean going ships, offshore platforms, etc. make it stand out from any other manufacturing industry. The size of a medium sized ocean going vessel could be anything between

100 to 150m in length whereas that of an ultra large crude carrier could be around 350m or more. It calls for usage of very large size basic structural components.

- ii) Time requirement – This huge size will naturally involve huge manhour for its fabrication. This has various implications, the time taken to complete one ship may extend from about 18-20 months to about 36 to 48 months or even more. For example an aircraft carrier may take around even something like 10 years to complete.
- iii) Cost and time of delivery of product – The cost can be extremely high, may vary from tens of crores of INR to thousands of crores. The most important thing is it is not a show case product. Hence the cost estimation and pricing is done at the contract stage, when there is only very scanty information available about the product. At this stage only preliminary design is only available, based on this the cost and delivery time is to be estimated. The overall time of construction being very high, the probability of disruption in production schedule causing cost overrun is also very high.
- iv) Ship's speed – The vessel on delivery should achieve the required speed as laid down by the client in the contract. If it fails by even half a knot, the shipbuilder will land up paying heavy demurrage. There is no scope of any prototype trial. The power estimation has to be done based on theoretical calculations and model testing only. One can not also afford to install higher power propulsion engine to play safe, because it will cause higher fuel consumption and the design will be considered as a bad design. this will have negative effect on the credibility of the shipyard.
- v) Unit product – It is a case of unit product, not a mass production item like say automobiles or television sets. Each and every ship is unique in its design, even if there are vessels in series construction, the series size could be hardly 5 or 6. The spacing of delivery of these vessels could some where between 6 to say 12 months or may be even more. Hence it loses all the benefits of being in series production.
- vi) Skills and Trades – It requires a wide variety of skills and trades ranging from carpenter to electronic engineer.
- vii) Materials – A wide variety of materials are used, like curtain material to high tensile steels.
- viii) Organisational aspects – The wide variety of materials, large number of work force, huge size of structures, wide variety of equipment and machineries, large production time all taken together pose a very difficult and complex organizational issue in front of the shipyards' management.

Q.23 What framing system is most suitable for stiffening the deck, wing tank structure, double bottom and side shell in case of a dry bulk carrier. Explain with suitable sketches.

Since the dry bulk carriers can be of sizes ranging from 150m to 250m, with a block coefficient of about 0.75, it behaves more like a slender structure. Thus the longitudinal bending stresses are more significant compared to other stresses. Hence it is preferable to adopt longitudinal framing system as much as possible. Therefore the deck, wing tanks and the double bottom are stiffened with longitudinal framing system, whereas the side

shell has transverse framing system. These strength requirements can also be satisfied with transverse framing system, but it will lead to a structure having lower strength to weight ratio. Whereas longitudinal framing system provides for higher buckling strength thereby the deck and bottom shell being subjected to highest compressive bending stresses will have better load bearing capacity as far as compressive and tensile loads are concerned. Hence it will lead to a lighter structure with adequate strength characteristics. Since the wing tanks as well as the double bottom space are not meant for carrying any cargo but may be used to carry some liquids like ballast water, fuel oil, lub oil, etc., here also longitudinal framing system is adopted to derive the maximum benefit of higher strength to weight ratio. However the side shell is stiffened using transverse framing system. This is because if longitudinal framing system is adopted then the side shell longitudinals would have behaved like shelves causing cargo to remain there even after unloading of cargo. This may cause cargo contamination as well as the cargo remains being generally hygroscopic may initiate galvanic corrosion in those areas, particularly at the weld zone. This situation is totally avoided by using transverse framing system. At the same time the side shell with transverse frames provides for a good support structure for the heavy top wing tank. A typical section of a bulk carrier is shown in the following figure.

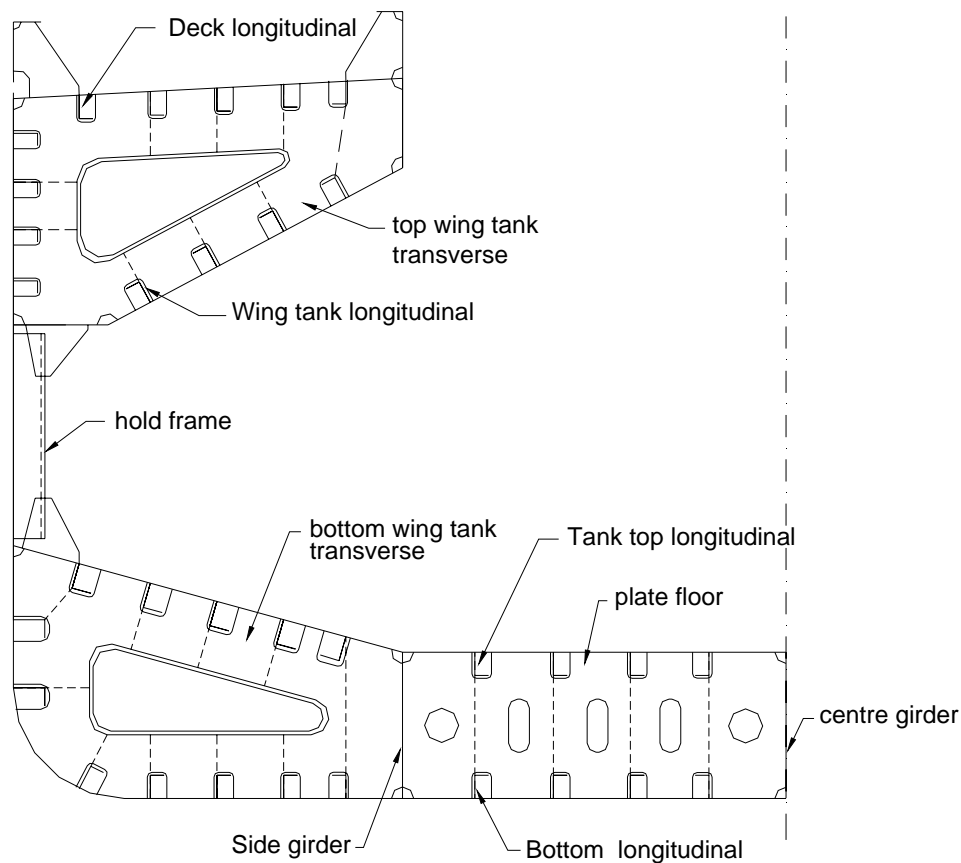

A typical midship section of a bulk carrier

Q.24 Mention the functions of subdivision water tight bulkheads. What stiffening arrangement is followed in case of a stiffened plate subdivision bulkheads of a general cargo carrier.

The functions of subdivision water bulkhead are,

- i) Subdivision watertight bulkheads divide the ship into several watertight compartments.
- ii) If by accident any compartment gets flooded, the flooding is kept confined within that compartment by these bulkheads. These are designed to take the hydrostatic load in case of flooding.
- iii) Subdivision watertight bulkheads also support the longitudinals. Longitudinals are continuous members and they pierce through these bulkheads. They are welded to bulkheads and the opening is thoroughly sealed to make them water tight. Thus it provides support to the longitudinals.
- iv) These bulkheads are one of the major members providing transverse strength to the hull structure.
- v) Should any fire break out, these bulkheads should also be able to confine the fire within the hold. This talks about the material of the bulkhead, it cannot be made of any easily combustible or low melting material.

In case of stiffened plate subdivision bulkhead of general cargo carrier vertical stiffeners are used. Since such vessels will generally have at least one lower deck and tank top, therefore the vertical stiffeners of the bulkhead will get a natural support at these intermediate points. This will reduce their free span and thus the resulting bending moment for the same load will be highly reduced. Thus stiffeners of lower scantlings can be used to attain same amount of strength. A typical section is shown in the following figure:

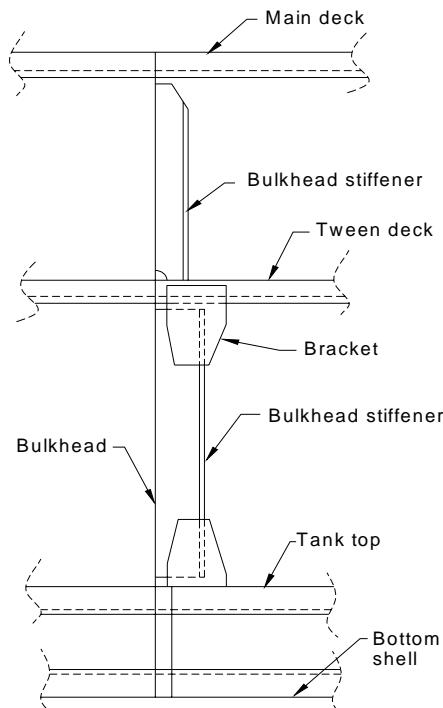

Q.25 Mention in general the longitudinal and transverse strength members of a ship.

Longitudinal strength members of a ship:

- i) Main deck plate
- ii) Deck longitudinals
- iii) Hatch side girder
- iv) Inner and outer side shell
- v) Inner and outer side shell longitudinals
- vi) Continuous lower deck plate
- vii) Lower deck longitudinals
- viii) Lower deck hatch side girder
- ix) Tank top
- x) Bottom shell
- xi) Tank top longitudinals
- xii) Bottom shell longitudinals
- xiii) Central girder
- xiv) Side girder
- xv) Sloping bulkheads of top and bottom wing tanks
- xvi) Wing tank longitudinals
- xvii) Longitudinal bulkhead

Transverse strength members of a ship:

- i) Main deck plate
- ii) Deck transverses
- iii) Deck beams
- iv) Hatch end beams
- v) Continuous lower deck plate
- vi) Lower deck transverses
- vii) Subdivision transverse water tight bulkhead
- viii) Side shell frames and web frames
- ix) Wing tank transverses
- x) Plate Floors and water tight floors

Q.26 In case of ship construction, which framing system is preferable for primary stiffening of decks and shells and why?

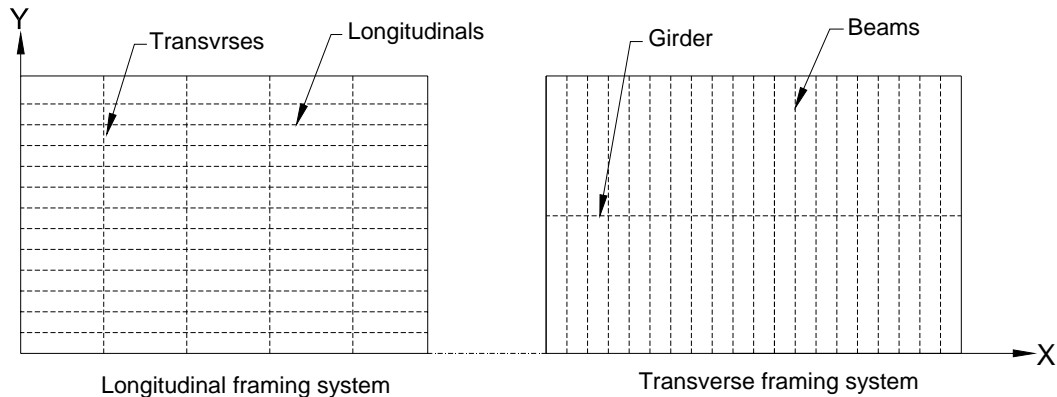

In the above figure X axis is along the length of a ship and Y axis along the breadth. Accordingly the longitudinal and transverse framing systems are defined.

Out of the above two possible framing systems, the longitudinal framing system is preferable, for the following reasons:

i) $\sigma_{cr(L)} > \sigma_{cr(T)}$

The critical buckling stress in longitudinal framing system is greater than that of transverse framing system. Ocean going ships behave like a slender beam because of its rather high length to breadth ratio. It is generally in the range of 3 to 6. At the same time the length of a medium sized ship can be around 100 m. Hence the longitudinal bending stresses occurring in the deck and double bottom structure becomes important from structural design point of view.

The magnitude of the stresses at these members is highest because they are furthest from the neutral axis. Depending on the bending moment these longitudinal bending stresses can be of compressive or tensile nature. Actually with the wave action the stresses keep reversing, i.e. the deck and the bottom structures get subjected to cyclic loading. While in tension there could be a possibility of tensile failure and buckling failure may occur due to compressive loading. Now buckling may occur at a stress level much below the yield stress. Hence the stiffening arrangement of these structures should be such that it provides for high section modulus to take care of tensile loading and high critical buckling stress to withstand compressive loading without failure. This is obviously best achieved by adopting longitudinal framing system as shown in the above figure.

ii) $W_L < W_T$

Weight of stiffened panel with longitudinal framing is less than that of in transverse framing system.

To provide for the required tensile and buckling strength, the scantlings of the stiffening members as well the plate thickness in case of transversely framed stiffened panels is more compared to that in longitudinal framing system. Hence the weight of transversely framed panels works out to be more than longitudinally framed panels having same load bearing capacity. Therefore the strength to weight ratio in case of longitudinal framing system is higher than that of transverse framing system.

For both the above reasons, longitudinal framing is preferable for primary stiffening of decks and shells.

Q.27 Explain with a neat sketch the plating arrangement, indicating the variation in plate thickness if any, of a part of the main deck of a general cargo carrier showing hatch opening.

Typical plating arrangement of a deck with hatch opening is shown below.

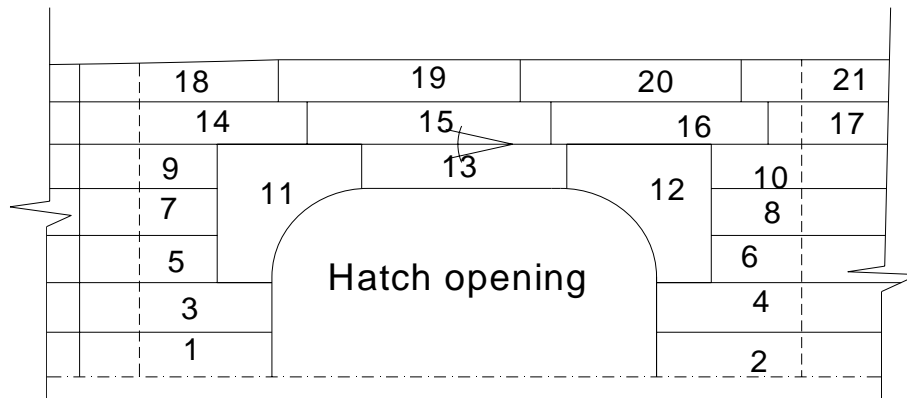

Let the plate thicknesses be denoted by t with the number suffix.

t_{11} and t_{12} are the insert plates. These plates will be of highest thickness.

t_1 , to t_8 are the plates within the line of opening.

t_9 , t_{10} , t_{13} , and t_{14} to t_{21} are the plates outside the line of opening.

The plates outside the line of opening i.e. t_9 , t_{10} , t_{13} , and t_{14} to t_{21} will be of higher thickness than t_1 , to t_8 which are within the line of opening. This is because the plates outside the line of opening will take part in longitudinal bending, i.e. these plates will contribute to longitudinal strength. Whereas the plate strakes within the line of opening being of much smaller length (less than 15% the length of the ship) will not contribute to the longitudinal strength, i.e. will not resist longitudinal bending. This part of the deck structure is referred to as cross deck structure. However the insert plates at the hatch corners will be of highest thickness, to account for the stress concentration at these corners.

Q.28 Make a neat sketch of the midship section of a general cargo carrier, section taken through a plate floor.

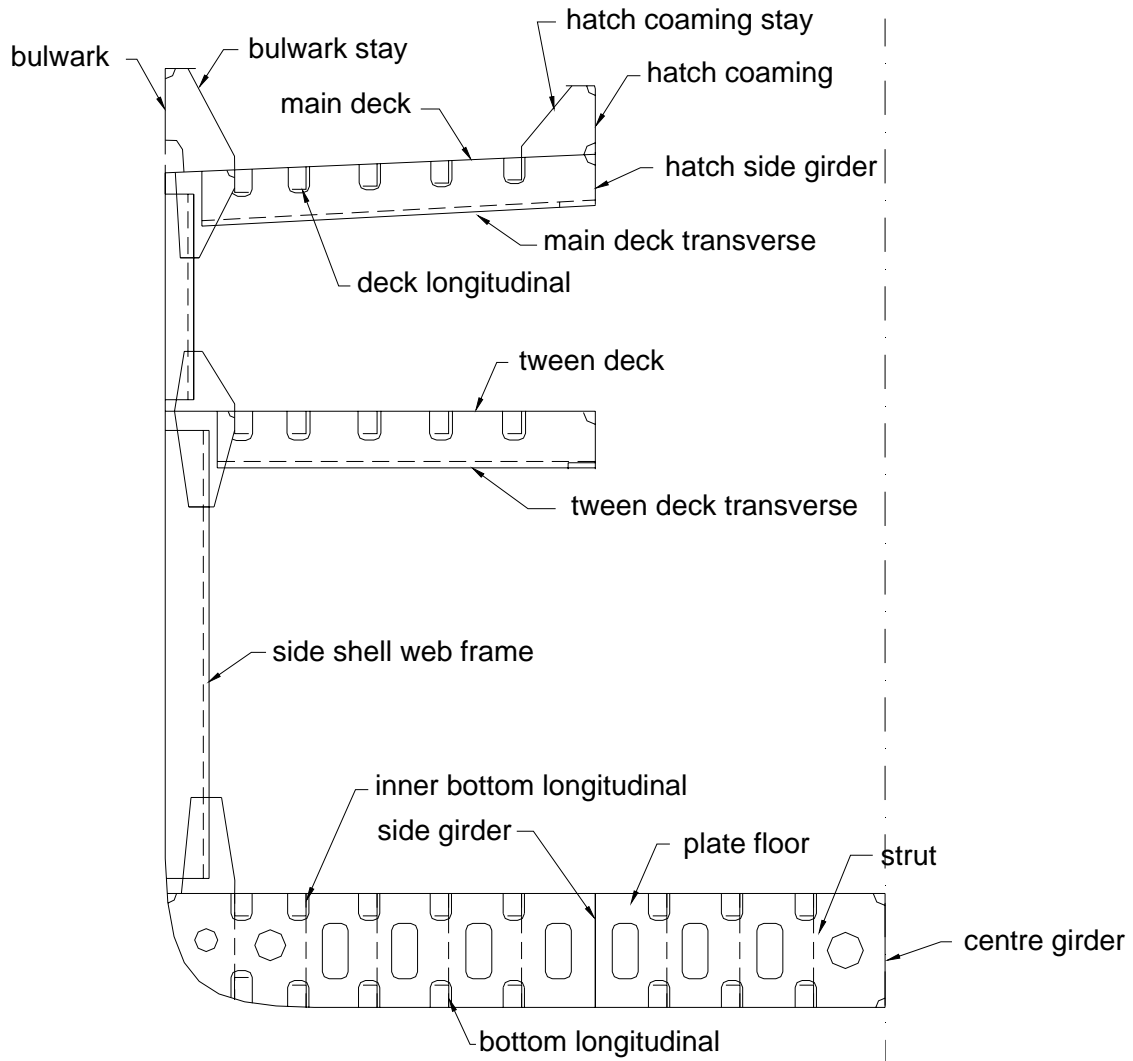

Midship section of a general cargo carrier

Q.29 Make a neat sketch of the midship section of a OBO cargo carrier, section taken through a plate floor.

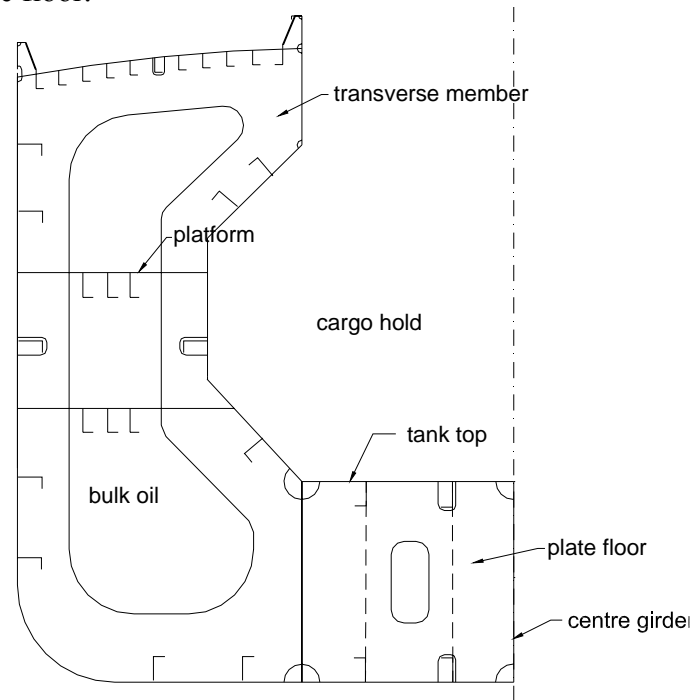

Midship section of an OBO carrier

Q.30 Make a neat sketch of the midship section of a crude carrier showing a duct keel arrangement and section taken through a plate floor.

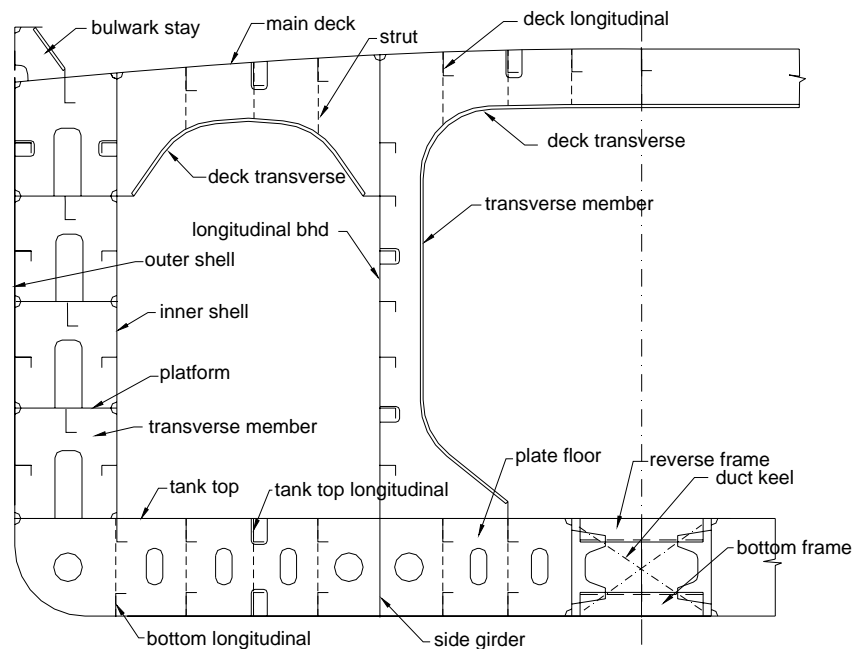

Midship section of a crude carrier showing duct keel arrangement